

Stufe a Legna

Wood Stoves - Poêles à bois
Holzöfen - Estufas de Leña



P.2 Piazzetta Total Comfort
P.4 Passione Accesa da oltre 60 anni
P.6 Prodotti fatti per durare nel tempo
P.8 Stufe a legna
P.12 Multifuoco® System
P.24 Heat Storage System (HSS)
P.28 I vantaggi di un focolare Ermetico
P.30 BCS, la comodità di una gestione elettronica
P.34 Maiolica artigianale
P.36 Gamma stufe a legna
P.38 Stile e arredo

P.52 Performance e versatilità
P.94 Stile esclusivo
P.108 L'originale stufa-caminetto
P.124 Per riscaldarsi e cucinare
P.130 Trend Line
P.142 Maiolica in oltre 40 tonalità
P.144 Caratteristiche
P.189 Legenda
P.193 Assistenza specializzata
P.193 Estensioni di garanzia
P.194 Indice

EN

P.2 Piazzetta Total Comfort
 P.4 A burning passion for over 60 years
 P.6 Products that endure time
 P.8 Wood-burning Stoves
 P.12 Multifuoco® System
 P.24 Heat Storage System (HSS)
 P.28 The advantages of an Airtight firebox
 P.30 BCS, the convenience of electronic control
 P.34 Handcrafted majolica
 P.36 Wood-burning stove range
 P.38 Style and furnishing
 P.52 Performance and versatility
 P.94 Original design
 P.108 The original stove-fireplace
 P.124 For heating and cooking
 P.130 Trend Line
 P.142 Majolica offered in over 40 shades
 P.144 Characteristics
 P.189 Key
 P.193 Specialised support
 P.193 Warranty extensions
 P.194 Index

DE

Piazzetta Total Comfort
 Passion enflammée depuis plus de 60 ans
 Produkte, die Jahrzehnte überdauern
 Holzöfen
 Multifuoco® System
 Heat Storage System (HSS)
 Die Vorteile eines raumluftunabhängigen Heizeinsatzes
 BCS, die Bequemlichkeit einer elektronischen Steuerung
 Handwerkliche Fertigung
 Holzofen-Serie
 Stil und Einrichtung
 Leistung und Vielseitigkeit
 Originelle Exklusivität
 Der originelle Kaminofen
 Zum Heizen und Kochen
 Trend Line
 Majolika in über 40 Farben
 Eigenschaften
 Legende
 Assistance spécialisée
 Extensions de garantie
 Index

FR

P.2 Piazzetta Total Comfort
 P.4 Brennendes Feuer seit über 60 Jahren
 P.6 Des produits faits pour durer dans le temps
 P.8 Poêles à bois
 P.12 Multifuoco® System
 P.24 Heat Storage System (HSS)
 P.28 Les avantages d'un foyer étanche
 P.30 BCS, le confort de la gestion électronique
 P.34 Faïence artisanale
 P.36 Gamme de poêles à bois
 P.38 Style et décoration d'intérieur
 P.52 Performances et polyvalence
 P.94 Exclusivité originale
 P.108 Le poêle-cheminée original
 P.124 Pour se chauffer et cuisiner
 P.130 Trend Line
 P.142 Faïence disponible dans plus de 40 teintes
 P.144 Caractéristiques
 P.189 Légende
 P.193 Spezialisierter kundendienst
 P.193 Garantieverlängerungen
 P.194 Index

ES

Piazzetta Total Comfort
 Pasión encendida desde hace más de 60 años
 Productos hechos para durar a lo largo del tiempo
 Estufas de leña
 Multifuoco® System
 Heat Storage System (HSS)
 Las ventajas de un hoga hermético
 BCS, la comodidad de una gestión electrónica
 Mayólica artesanal
 Gama de estufas de leña
 Estilo y decoración
 Desempeño y versatilidad
 Exclusividad original
 La original estufa-chimenea
 Para calentarse y cocinar
 Trend Line
 Mayólica en más de 40 colores
 Características
 Leyenda
 Asistencia especializada
 Extensiones de garantía
 Index

Idee intorno al fuoco

Realizzare soluzioni innovative di riscaldamento, unire qualità ed estetica, sviluppando intorno al fuoco nuove idee ed atmosfere per farne il vero centro della casa: questo è l'impegno di Piazzetta.



EN Ideas around the fire

Create innovative heating solutions, merging quality and aesthetics, develop new ideas and atmospheres around fire to make it the fulcrum of the home: these are the objectives that Piazzetta pursues.

FR Des idées autour du feu

Réaliser des solutions innovantes, allier la qualité à l'esthétique, développer de nouvelles idées autour du feu et créer la juste atmosphère pour le mettre au cœur de la maison : c'est là l'engagement de Piazzetta.

DE Ideen rund ums Feuer

Innovative Heizlösungen realisieren, Qualität und Ästhetik miteinander verbinden, neue Ideen und Atmosphären rund ums Feuer entwickeln, um es zum Mittelpunkt des eigenen Heims werden zu lassen: Dafür steht Piazzetta.

ES Ideas alrededor del fuego

Realizar soluciones innovadoras de calefacción, unir la calidad a la estética, desarrollando alrededor del fuego nuevas ideas y atmósferas para convertirlas en el verdadero centro de la casa: es el compromiso de Piazzetta.

Piazzetta Total Comfort

Scegli tra la più ampia gamma di caminetti e stufe a legna, pellet, gas. Stile, design, tecnologia, qualità dei prodotti e la ricercatezza dei particolari tutta italiana. Un mondo di certezze sul quale contare, anche grazie alla professionalità dei centri di assistenza tecnica Piazzetta sul territorio. Professionisti a tua disposizione formati dall'Azienda, sempre aggiornati e disponibili.

EN Choose among the widest range of wood, pellet and gas burning stoves and fireplaces. Distinctly Italian in style, design, technology product quality and refined details. A world of certainties which you can rely on thanks to the expertise available through Piazzetta trained service centres. Up-to-date professionals willing to assist you.

FR Choisissez parmi la plus riche gamme de cheminées et poêles à bois, pellet ou gaz. Style, design, technologie, qualité des produits et raffinement des détails typiquement italien. Un monde de certitudes sur lequel compter, grâce au professionnalisme des Service après vente Piazzetta, formés par notre entreprise et toujours disponibles.

DE Wählen Sie aus dem größten Angebot an Kaminen und Öfen mit Holz-, Pellet- oder Gasfeuerung das für Sie passende Modell aus. Stil, Design, Technologie, Produktqualität und raffinierte Detailauswahl auf Italienisch. Eine Welt sicherer Werte, auf die Sie zählen können, auch dank der regionalen, professionellen Techn. Kundendienste die von Piazzetta aus- und weitergebildeten werden.

ES Elige entre la más amplia gama de chimeneas y estufas de leña, pellets, gas. Estilo, diseño, tecnología, calidad de producto, detalles refinados puramente italianos. Un mundo de certezas con las que contar, incluso por la profesionalidad de los centros de asistencia técnica Piazzetta. Profesionales a tu disposición, siempre informados, capacitados por la empresa.



Passione Accesa da oltre 60 anni

La nostra è una passione artigiana tutta italiana, dove estetica e tecnologia si uniscono per creare elementi di arredo protagonisti del vivere moderno. Da sempre ricerchiamo e progettiamo in Italia, ad Asolo, soluzioni esclusive, offriamo in ogni nostro prodotto i massimi standard di efficienza, praticità, sicurezza, con un design ed una qualità dei materiali e delle lavorazioni che ci contraddistinguono.



1960 - 2020



EN A burning passion for over 60 years.

Genuine Italian artisan passion merging aesthetics and technology to create furnishing elements that exemplify modern day living. Our Italian cultural roots have always been based in Asolo where we set our goals to achieve the highest standards in efficiency, practicality and the utmost in safety in each of our products which reflect our unique characteristic of design and quality.

FR Passion enflammée depuis plus de 60 ans

Notre passion est une passion artisanale 100% italienne où esthétique et technologie donnent vie à des éléments véritables acteurs de la vie contemporaine. C'est en Italie, à Asolo que nous recherchons et concevons depuis toujours des solutions exclusives. Nous offrons à travers chacun de nos produits les plus hauts standards de rendement, confort d'utilisation et sécurité, avec un design et une qualité des matériaux et des réalisations qui nous caractérisent.

DE Brennendes Feuer seit über 60 Jahren.

Unser Handwerk leben wir mit italienischer Leidenschaft und als gelungene Verknüpfung von Ästhetik und Technologie zur Herstellung von Einrichtungsgegenständen, die zu Protagonisten modernen Wohnens geworden sind. Seit der Gründung unserer Firma forschen und entwickeln wir im norditalienischen Asolo, um exklusive Lösungen, hohe Benutzerfreundlichkeit, Sicherheit, erlesenes Design und beste Qualität zu liefern.

ES Pasión encendida desde hace más de 60 años

La nuestra es una pasión artesanal totalmente italiana, donde la estética y la tecnología se unen para crear elementos de decoración protagonistas del vivir moderno. En Asolo, Italia, concebimos y diseñamos soluciones exclusivas, ofrecemos en cada producto los máximos estándares de eficiencia, practicidad, seguridad, con un diseño y una calidad de material y elaboración que nos distingue.



Prodotti fatti per durare nel tempo

La solidità dei nostri prodotti è fatta di tanta esperienza e continua ricerca. Dalla selezione delle materie prime alle singole fasi di lavorazione, tutto viene controllato nei minimi dettagli da personale specializzato. Nei nostri laboratori si sviluppa il prodotto e viene testata la produzione e la rispondenza alle normative internazionali. Le stufe Piazzetta mantengono le loro caratteristiche nel tempo, per questo offriamo una estensione gratuita della garanzia per 5 anni.

EN Products that endure time.

The sturdiness of our products stems from extensive experience and on-going research. Starting from the selection of raw materials to every single processing phase, everything is checked right down to the slightest detail by our specialized personnel. In our laboratories the products are tested for their conformity to international regulations. Piazzetta stoves retain their characteristic over time: this is why we offer a free - 5 year warranty extension.

DE Produkte, die Jahrzehnte überdauern.

Die solide Struktur unserer Produkte basiert auf langjähriger Erfahrung und kontinuierlicher Forschung. Von der Auswahl der Rohstoffe bis zu den einzelnen Bearbeitungsphasen wird alles bis ins kleinste Detail von spezialisierten Fachkräften kontrolliert. Unsere Labors entwickeln das Produkt, testen die Produktion und prüfen das Resultat mit den Vorgaben internationaler Normen. Die Öfen von Piazzetta behalten ihre Wertigkeit über lange Zeit, weshalb wir bei der Brennkammer eine kostenlose Erweiterung der Garantie auf über 5 Jahre gewährleisten können.

ES Productos hechos para durar a lo largo del tiempo

La solidez de nuestros productos está hecha de mucha experiencia y de continuos estudios. Desde la selección de las materias primas hasta las fases de elaboración, todo es detalladamente controlado por personal especializado. En nuestros talleres se desarrolla el producto, se verifica la producción y se comprueba la conformidad con las normas internacionales. Las estufas Piazzetta mantienen sus características a lo largo del tiempo. Por eso ofrecemos gratuitamente una extensión de 5 años de la garantía.

FR Des produits faits pour durer dans le temps

Nos produits doivent leur solidité à notre bagage d'expérience et à notre travail de recherche continue. Du choix des matières premières aux nombreuses phases de réalisation, tout est contrôlé dans le moindre détail par notre personnel spécialisé. Nos ateliers développent le produit et font des essais sur la production et sur sa conformité aux normes internationales. Les poêles Piazzetta conservent leurs caractéristiques au long des années, c'est d'ailleurs pour cette raison que nous offrons une extension de garantie de 5 ans.

EASY LIFE
PIAZZETTA

GARANZIA
WARRANTY

5

ANNI-YEARS

RICAMBI
PARTS

10

ANNI-YEARS

easylife.piazzetta.com

Certificazioni
EN Certifications
FR Certifications
DE Zertifizierungen
ES Certificaciones





Stufe a Legna

Wood-burning Stoves
Poêles à bois
Holzöfen
Estufas de leña

Caratteristiche della Legna

La legna è il combustibile naturale per eccellenza, da sempre fonte primaria per riscaldare e per cucinare. Attorno al fuoco della legna ritroviamo gesti ed emozioni che arrivano dalla storia dell'uomo. La legna da ardere proviene principalmente dall'attività forestale controllata.

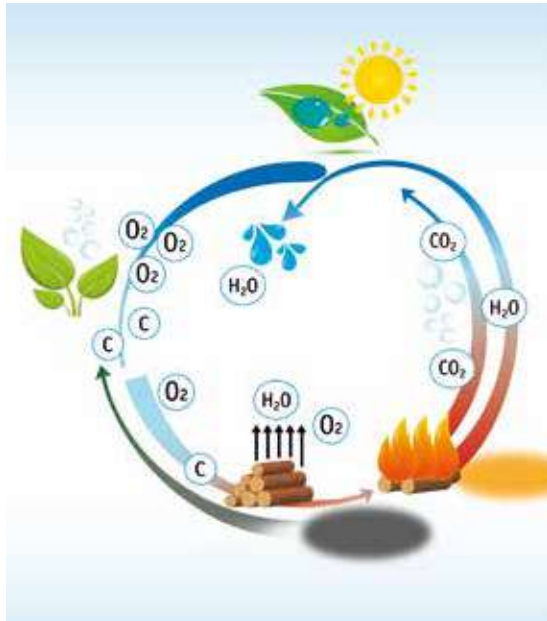

EN Properties of Wood

Wood is the best natural fuel and has always been a primary source for heating and cooking. A wood fire contains gestures and feelings as old as the history of man. Wood fuel comes mainly from monitored forests.

FR Caractéristiques du bois

Le bois est depuis toujours le combustible naturel utilisé pour le chauffage et la cuisine. Autour du feu de bois, nous retrouvons des gestes et des émotions qui remontent à l'aube de notre histoire. Le bois de chauffage provient principalement de l'activité forestière contrôlée.

DE Eigenschaften des Holzes

Holz ist ein hervorragendes natürliches Brennmittel, das schon immer zum Heizen und Kochen verwendet wurde. Am Feuer begegnen wir Gesten und Emotionen, die aus der Menschheitsgeschichte hervorgehen. Brennholz stammt hauptsächlich aus der kontrollierten Forstwirtschaft.

ES Características de la leña

La leña es el combustible natural por excelencia; fuente primaria sempiterna para calentar y cocinar. En torno al fuego de leña se producen sensaciones y emociones perpetuadas a lo largo de la historia del hombre. La leña proviene principalmente de explotación forestal controlada.

Scelta ecologica

Massimi rendimenti e minime emissioni. Accurati test di laboratorio e approfonditi studi termodinamici, hanno permesso ai prodotti Piazzetta di assicurare una resa ottimale: bassi consumi e una prolungata autonomia. A questo si aggiunge un ridotto tasso di emissioni in atmosfera, in linea con le più severe normative europee.



EN An eco-friendly choice

Maximum performance with minimal emissions. Thanks to rigorous laboratory tests and extensive thermodynamic studies, Piazzetta products are able to ensure optimal performance: low consumption and extended autonomy. In addition, they feature a low level of emissions into the atmosphere, in line with the most stringent European regulations.

FR Choix écologique

Rendements maximum et faibles émissions. Des essais de laboratoire minutieux ainsi que des études thermodynamiques, ont permis aux produits Piazzetta d'assurer un rendement optimal: basse consommation et autonomie prolongée, un taux réduit d'émissions, selon les normes européennes les plus strictes.

DE Umweltfreundlichkeit

Maximale Leistung - minimale Emissionen. Akkurate Tests im Labor und eingehende Studien zur Thermodynamik haben zur Optimierung der Produkte von Piazzetta beigetragen. Durch niedrigeren Verbrauch, längere Betriebszeiten und reduzierte Schadstoff-Emissionen werden so die strengsten europäischen Normen erfüllt.

ES Elección ecológica

Máximo rendimiento, mínimas emisiones. Pruebas de laboratorio y estudios termodinámicos exhaustivos han permitido a los productos Piazzetta garantizar un rendimiento térmico óptimo, bajos consumos y una larga autonomía. A esto se suma un bajo índice de emisiones atmosféricas, conforme a las normativas europeas más restrictivas.

STUFE A CONVEZIONE NATURALE



Le stufe a legna a convezione riscaldano l'ambiente con moti convettivi naturali e per l'irraggiamento della Maiolica che distribuisce il calore in modo confortevole e prolungato.

EN Natural convection stoves

Convection wood-burning stoves heat rooms using natural convection and radiated heat from the Majolica, distributing the heat in a comfortable and prolonged way.

DE Öfen mit Naturkonvektion

Holzöfen mit Naturkonvektion beheizen Räume mit natürlichen Konvektivbewegungen und die Strahlungswärme der erhitzten Majolika verteilt die Wärme auf angenehme verlängerte Weise.

FR Poêles à convection naturelle

Ce type de poêle chauffe l'espace par convection naturelle et grâce au rayonnement de la faïence qui distribue la chaleur de manière confortable et prolongée.

ES Estufas de convección natural

Las estufas de leña de convección calientan el ambiente por convección natural y por irradiación de la mayólica para una distribución de calor confortable y duradera.



STUFE MULTIFUOCO® SYSTEM



Le stufe a legna possono essere dotate dell'esclusivo Multifuoco® System e Multifuoco® System Plus, per riscaldare uniformemente anche a ventilazione forzata.

EN Multifuoco® System Stoves

Wood-burning stoves can be fitted with the exclusive Multifuoco® System, and Multifuoco® System Plus, for uniform heating with forced ventilation.

DE Öfen Multifuoco® System

Die Holzöfen können mit dem exklusiven Multifuoco® System und Multifuoco® System Plus ausgestattet werden, das über ein Luftgebläse für eine gleichmäßige Wärmeverteilung sorgt.

FR Poêles Multifuoco® System

Les poêles à bois peuvent être dotés des systèmes exclusifs Multifuoco® System et Multifuoco® System Plus, pour un chauffage uniforme même à ventilation forcée.

ES Estufas Multifuoco® System

Las estufas de leña pueden equiparse con el exclusivo Multifuoco® System y Multifuoco® System Plus, para calentar uniformemente incluso con ventilación forzada.



STUFE AD ACCUMULO



Inserire in una stufa a legna un sistema di accumulo significa garantire, per molte ore ancora dopo lo spegnimento del fuoco, un confortevole riscaldamento per irraggiamento.

EN Heat storage stoves

Fitting a wood-burning stove with a heat storage system ensures comfortable heating via radiation for many hours after the flame has gone out.

DE Öfen mit Wärmespeicher

Die Integration eines Wärmespeichers in einen Holzofen garantiert auch Stunden nach Erlöschen der Flamme eine angenehme Beheizung durch Strahlungswärme.

FR Poêles à accumulation

Insérer dans un poêle à bois un système d'accumulation, c'est garantir un chauffage confortable par rayonnement plusieurs heures après l'extinction du feu.

ES Estufas de acumulación

Integrar en una estufa de leña un sistema de acumulación, significa garantizar una calefacción confortable por irradiación muchas horas después de que se ha apagado el fuego.



Il benessere del fuoco a legna

Il benessere del fuoco a legna è dato dalla sua origine naturale, dal suo potere calorifico, dal riscaldamento degli elementi radianti e dall'insuperabile affascinante bellezza evocativa del fuoco.

EN The comfort of wood fires springs from its natural origins, its heating power, the heating of radiating elements and the timeless beauty of the flame.

FR Le bien-être procuré par le feu de bois provient de son origine naturelle, son pouvoir calorifique, le chauffage des éléments rayonnants et l'inimitable et fascinante beauté évocatrice du feu.



The comfort of wood fires
Le bien-être du feu de bois
Die Wirkung von Holzfeuer auf
das Wohlbefinden
El bienestar del fuego de leña

DE Die Wirkung von Holzfeuer auf das Wohlbefinden beruht auf seinem natürlichen Ursprung, seinem Heizwert, der Erwärmung von Strahlungselementen und der unübertrefflichen beschwörenden Schönheit des Feuers.

ES El bienestar del fuego de leña se debe al origen natural de esta, a su poder calorífico, a la calefacción de los elementos radiantes y a la insuperable y fascinante belleza evocadora del fuego.



Multifuoco[®] System

20°C

- **Uniformità di riscaldamento in tutto l'ambiente, dal pavimento al soffitto, senza sprechi.**
- **Definisci la temperatura di comfort, dove tu sei, Multifuoco[®] la mantiene.**
- **Percepisci sempre un calore confortevole in tutto il corpo, mai più piedi freddi.**
- **Uniform heating throughout your living areas, from the floor to the ceiling.**
- **Set you comfort temperature wherever you are and the Multifuoco[®] system will maintain it.**
- **Your body will always feel warm and comfortable; no more cold feet.**
- **Uniformité de chauffage dans toute la pièce du sol au plafond, sans gaspillages.**
- **Définissez la température de confort où vous vous trouvez, Multifuoco[®] se charge de la maintenir.**
- **Une chaleur confortable est perçue dans tout le corps. Vous n'aurez plus jamais les pieds froids.**

20°C

20°C

- Gleichmäßige und sparsame Beheizung des gesamten Raums vom Fußboden bis zur Decke.
- Stellen Sie Ihre gewünschte Komforttemperatur dort ein, wo sie benötigt wird - Multifuoco® hält sie stabil.
- Sie werden immer eine angenehme Wohlfühltemperatur spüren und keine kalten Füße mehr haben.
- Uniformidad de calefacción en todo el ambiente, del suelo al techo, sin desperdicios.
- Elige tu temperatura de confort donde te encuentres. Multifuoco® la mantiene.
- Percibe siempre un calor confortable en todo el cuerpo. Nunca más pies fríos.



Multifuoco® System

Solo con l'esclusivo Multifuoco® System il calore viene immesso dal basso. Questa caratteristica modalità brevettata consente di mantenere uniforme la temperatura in ambiente, grazie alla generazione di naturali moti convettivi, favoriti dal prelievo dell'aria per il riscaldamento dall'alto della stufa. Multifuoco® System evita di stratificare calore in prossimità del soffitto e riscalda anche all'altezza del pavimento (i nostri piedi). Il calore viene distribuito uniformemente in ambiente, ad elevata temperatura e con una bassa velocità in uscita per garantire la massima silenziosità.

EN Only with the exclusive Multifuoco® System, heat is introduced into the room from the floor level. This patented characteristic process maintains a unified room temperature, thanks to the natural convection currents which allow the stove to draw air from above; where air is warmer. The Multifuoco® System prevents heat stratification occurring at ceiling level rendering more heat at floor level compared to conventional stoves. Heat is conveyed uniformly into the room with maximum silence during operation.

DE Nur mit dem exklusiven Multifuoco® System strömt die Wärme von unten über den Boden in den Raum. Diese patentierte Betriebsweise ermöglicht es, eine einheitliche Temperatur im Raum zu behalten, die durch natürliche Konvektivbewegungen entsteht, wobei die Luft zur Beheizung aus dem Bereich über dem Ofen angesaugt wird. Multifuoco® verhindert somit die Schichtung der Wärme direkt unter der Decke und heizt auch auf Höhe des Bodens (d.h. die Füße). Die Wärme wird gleichmäßig im Raum verteilt; dies erfolgt mit hoher Auslaß-Temperatur und niedriger Geschwindigkeit, um so maximale Laufruhe zu garantieren.

FR Seul l'exclusif Multifuoco® System permet l'émission de la chaleur par le bas. Ce mode d'émission breveté permet de garder la température uniforme par génération de mouvements convectifs naturels, favorisés par le prélèvement de l'air de chauffage par le haut du poêle. Multifuoco® System évite la stratification de la chaleur près du plafond et chauffe au niveau du sol (pieds). La chaleur est distribuée de façon uniforme, à une température élevée et à faible vitesse en sortie pour un silence assuré.

ES Sólo con el exclusivo Multifuoco® System el calor se introduce en el ambiente desde abajo. Esta característica modalidad patentada permite mantener uniforme la temperatura ambiente gracias a la generación de movimientos convectivos naturales, favorecidos por la toma del aire de calefacción por la parte superior de la estufa. Multifuoco® System evita estratificar el calor cerca del techo, calentando también a la altura del suelo (pies). El calor se distribuye uniformemente en el ambiente, a alta temperatura y con una baja velocidad de salida, para garantizar el máximo silencio.

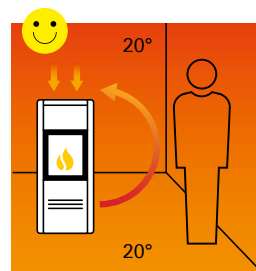

Riscaldamento Multifuoco® System

EN Heating with Multifuoco® System
FR Chauffage Multifuoco® System
DE Beheizung mit Multifuoco® System
ES Calefacción Multifuoco® System

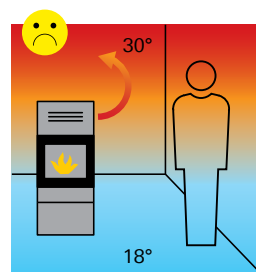

Riscaldamento tradizionale

EN Traditional Heating
FR Chauffage traditionnel
DE Traditionelle Beheizung
ES Calefacción tradicional

Sistema brevettato

- EN** Patented system
- FR** Système breveté
- DE** Patentiertes System
- ES** Sistema patentado

Uscita fumi.

- EN** Flue exit.
- FR** Sortie des fumées.
- DE** Rauchausgang.
- ES** Salida de humo.

Entrata dell'aria ambiente.

- EN** Ambient air inlet.
- FR** Entrée air ambiant.
- DE** Eintritt der Raumluft.
- ES** Entrada del aire ambiente.

Preriscaldamento aria.

- EN** Warm air.
- FR** Préchauffage air.
- DE** Vorgewärmte Luft.
- ES** Precalentamiento aire.

Flusso d'aria per la pulizia del vetro.

- EN** Airflow for glass cleaning.
- FR** Flux d'air pour nettoyer le verre.
- DE** Luftstrom zur Reinigung des Glases.
- ES** Flujo de aire para limpiar el cristal.

Aria comburente.

- EN** Combustion air.
- FR** Air comburant.
- DE** Verbrennungsluft.
- ES** Aire comburente.

Uscita aria per canalizzazione.

- EN** Ducting outlet.
- FR** Sortie d'air pour canalisation.
- DE** Luftaustritt zur Kanalisierung.
- ES** Salida del aire para la canalización.

Uscita aria calda in ambiente.

- EN** Hot air vent.
- FR** Sortie d'air chaud dans la pièce.
- DE** Austritt der Warmluft in den Raum.
- ES** Salida del aire caliente al ambiente.

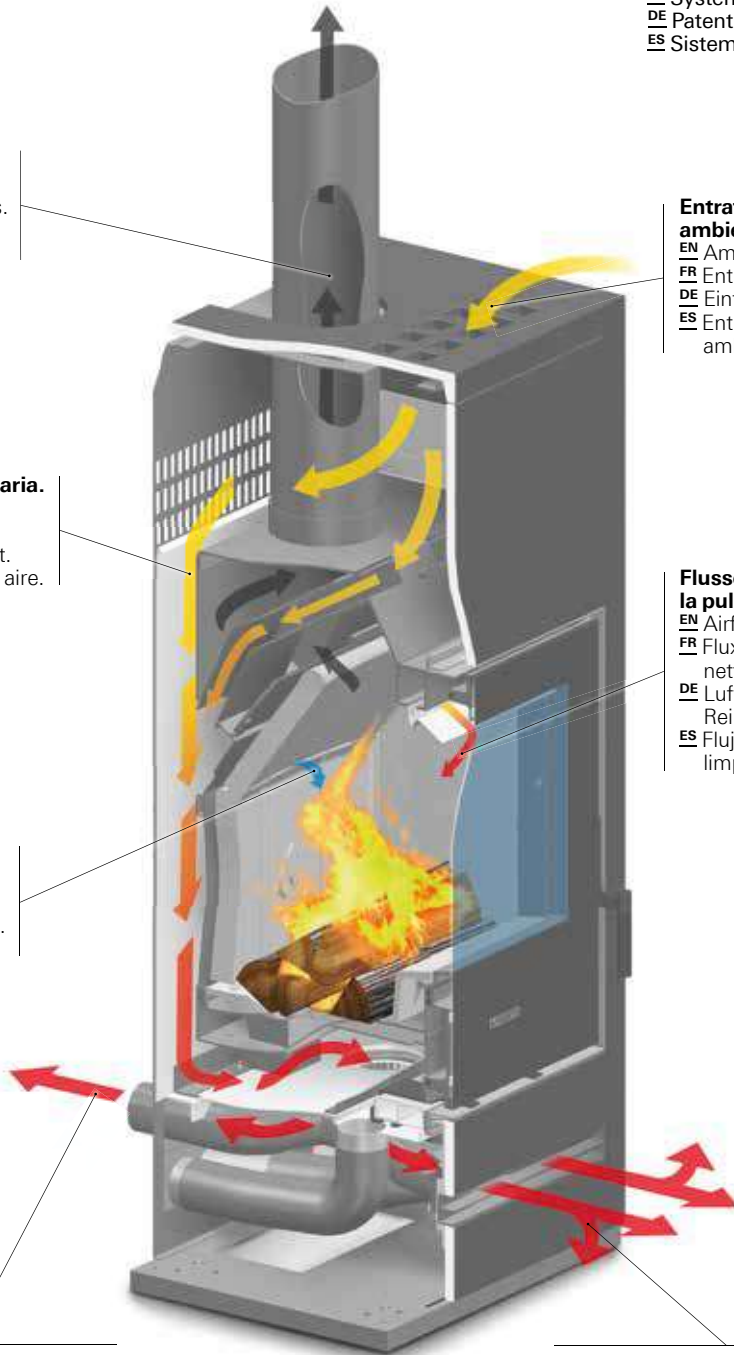

Multifuoco® System Plus

SYSTEM PLUS
multifuoco+

Innovativa versione a controllo elettronico

Multifuoco® System Plus è l'evoluzione dello straordinario sistema di ventilazione forzata Multifuoco® System dedicato alle stufe a legna. Il funzionamento dell'unità di ventilazione ambiente è costantemente controllato da una scheda elettronica che dialoga con il telecomando LCD dotato di sonda per la rilevazione della temperatura per un monitoraggio costante. La gestione, estremamente flessibile, consente di scegliere tra una gestione automatica, comfort e manuale. Il comfort giusto per tutta la tua casa.

EN Innovative version with electronic control

Multifuoco® System Plus is the latest development of the extraordinary Multifuoco® System forced ventilation system for wood-burning stoves. The operation of the room ventilation unit is constantly monitored by an electronic circuit that communicates with the LCD remote control equipped with temperature sensor for constant temperature monitoring. The extremely flexible control system allows you to choose between automatic, comfort and manual control. The right level of comfort for the entire home.

FR Une innovante version à contrôle électronique.

Multifuoco® System Plus est l'évolution de l'extraordinaire système de ventilation forcée Multifuoco® System dédié aux poêles à bois. Le fonctionnement de l'unité de ventilation ambiante est contrôlé en continu par une carte électronique qui dialogue avec la télécommande LCD dotée d'une sonde de détection de la température pour garantir un contrôle constant. La gestion extrêmement flexible du système permet de choisir entre les modes automatique, confort et manuel. Le confort idéal pour toute votre maison.

DE Innovative Version mit elektronischer Steuerung.

Multifuoco® System Plus ist die Weiterentwicklung des außergewöhnlichen Multifuoco® Belüftungssystems für Holzöfen. Der Betrieb der gesamten Gebläselüftung wird konstant von einer Platine gesteuert, die mit der LCD-Display ausgestatteten Fernsteuerung im Dialog steht und dank integriertem Temperaturfühler für die konstante Überwachung der Raumtemperatur sorgt. Aufgrund der extrem flexiblen Verwaltung kann man zwischen einem Automatik-, Komfort und manuellen Modus auswählen. Der richtige Komfort für Ihr Zuhause.

ES Versión innovadora con control electrónico.

Multifuoco® System Plus es la evolución del extraordinario sistema de ventilación forzada Multifuoco® System, pensado específicamente para las estufas de leña. El funcionamiento de la unidad de ventilación ambiente es controlado constantemente por una tarjeta electrónica que dialoga con el mando a distancia LCD provisto de sonda para la detección de la temperatura para un seguimiento continuo. La gestión, extremadamente flexible, presenta tres opciones: automática, confort y manual. El confort ideal para toda la casa.





Multifuoco® System Plus

Massima flessibilità di comando e gestione.

- **Gestione automatica:** avvio e spegnimento autonomo del ventilatore in base a una temperatura di soglia.
- **Gestione comfort:** raggiunta la temperatura impostata si può arrestare il ventilatore o modularne la potenza.
- **Gestione manuale:** raggiunta una temperatura di soglia il ventilatore passa alla modalità automatica.

Multifuoco® System Plus è compatibile con Burn Control System; si gestiscono con un solo telecomando.

EN Maximum flexibility.

- **Automatic control**
Automatic start-up and shut-down of the fan based on a threshold temperature.
- **Comfort control**
Once the set temperature has been reached, the fan can be stopped or the power can be modulated.
- **Manual control**
once the set temperature has been reached, the fan switches to automatic mode.

Multifuoco® System Plus is compatible with Burn Control System; controlled by a single remote control.

DE Maximale Steuer- und Verwaltungsflexibilität

- **Automatik**
Autonomes Ein- und Ausschalten des Lüfters auf Grundlage einer Grenztemperatur.
- **Komfort**
Der Lüfter schaltet sich aus oder verändert seine Leistung, nachdem die eingestellte Temperatur erreicht ist.
- **Manuell**
Der Lüfter schaltet in den Automatikmodus, bei Erreichen der Grenztemperatur.

Multifuoco® System Plus ist kompatibel mit dem Burn Control System; Verwaltung über eine einzige Fernsteuerung.

FR Flexibilité maximale de commande et de gestion

- **Mode automatique**
Démarrage et extinction autonomes du ventilateur selon une température seuil.
- **Mode confort**
À l'atteinte de la température configurée, on peut arrêter le ventilateur ou moduler sa puissance.
- **Mode manuel**
À l'atteinte de la température seuil, le ventilateur passe en automatique.

Compatibilité avec le Burn Control System et gestion depuis une seule et même télécommande.

ES Máxima flexibilidad de mando y gestión

- **Gestión automática**
Encendido y apagado autónomo del ventilador según el umbral de temperatura.
- **Gestión confort**
Al alcanzar la temperatura establecida, se puede parar el ventilador o modular su potencia.
- **Gestión manual**
Al alcanzar la temperatura de umbral, el ventilador entra en el modo automático.

Multifuoco® System Plus es compatible con Burn Control System; se requiere un solo mando a distancia.





SYSTEM PLUS
multifuoco+

Canalizzazione con Multifuoco®

Attraverso un semplice sistema di canalizzazione, realizzato con tubi flessibili dal diametro ridotto, è possibile riscaldare anche altri ambienti della casa. La diffusione del calore è ancora più confortevole e uniforme, essendo effettuata da più punti, con bocchette dotate di regolazione di flusso. La facile posa dei condotti di canalizzazione consente di realizzare un sistema di riscaldamento versatile, in locali adiacenti o canalizzabili fino a 12 m. La canalizzazione può essere effettuata orizzontalmente o verticalmente, sia al piano superiore sia a quello inferiore.

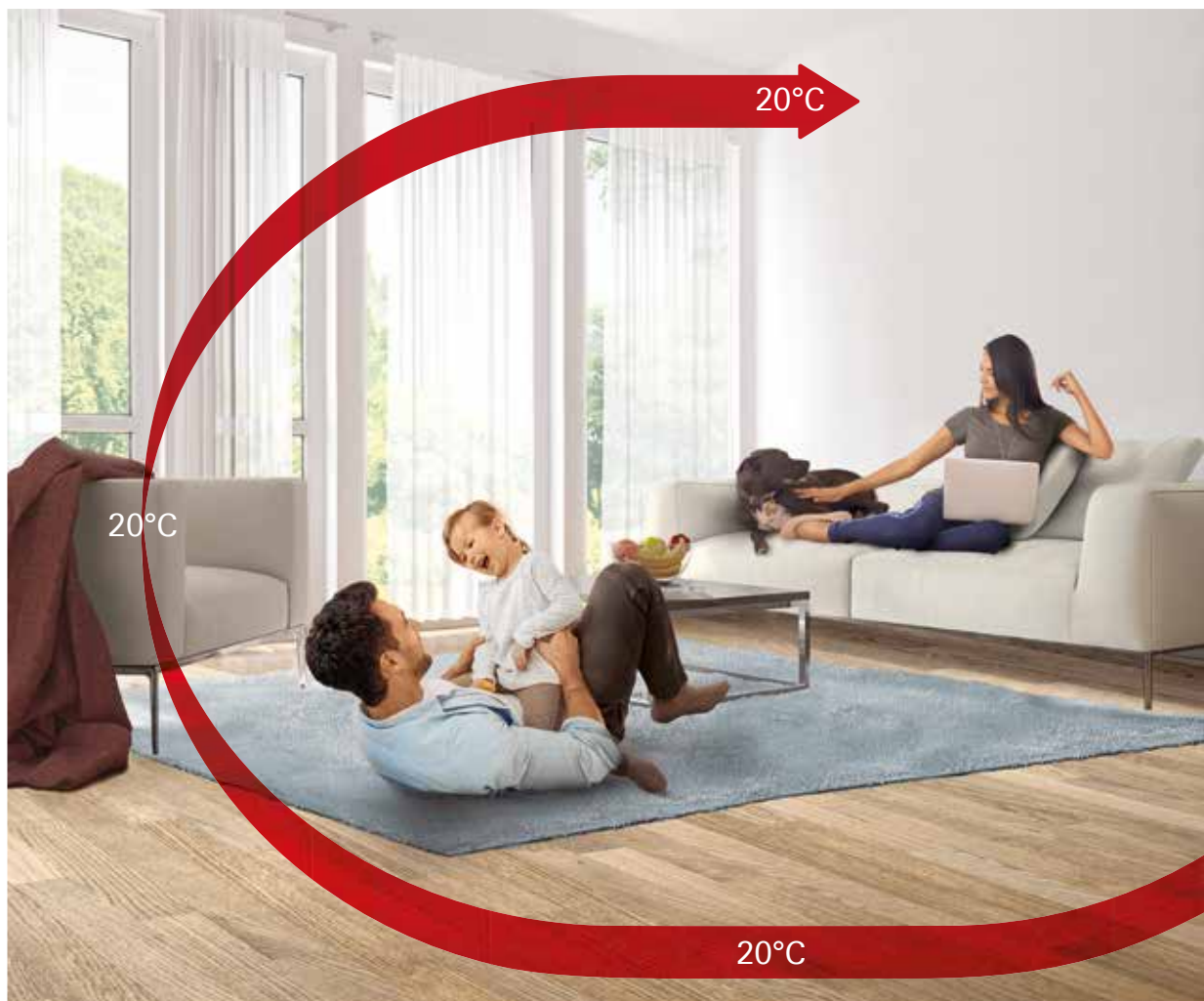

EN Ducting with Multifuoco®

Other rooms in the home can benefit from this system which can be simply ducted using small diameter flexible duct pipe. Diffusion of heat is even more notable through multiple flow regulating hot air vents positioned in other rooms. Easy laying of the ducting conduits creates a versatile heating system, in adjacent rooms up to 12 metres. Ducting can be either horizontal or vertical runs and the system will perform on either upper or lower floors.

FR Canalisation avec Multifuoco®

A travers un simple système de canalisation, réalisé avec des conduits flexibles de faible diamètre, il est possible de chauffer d'autres pièces de la maison. La diffusion de la chaleur, à travers des bouches de diffusion pourvues d'un réglage de flux, est encore plus confortable et uniforme. La pose aisée des conduits de canalisation permet de réaliser un système de chauffage polyvalent, dans les pièces voisines ou canalisables jusqu'à 12 m. La canalisation peut être horizontale ou verticale, tant à l'étage supérieur qu'inférieur.

DE Kanalisierung mit Multifuoco®

Über ein einfaches Kanalsystem aus flexiblen Rohrleitungen mit reduziertem Durchmesser ist es möglich, auch andere Räume zu beheizen. Die Verteilung der Wärme erfolgt noch komfortabler und gleichmäßiger, da sie an mehreren Stellen über Öffnungen mit Luftstromregulierung austritt. Die problemlose Verlegung der Rohrleitungen erlaubt die Realisierung eines vielseitigen Heizsystems in angrenzende Räume oder mit Kanalisierungen bis 12 m Länge. Das Kanalsystem kann horizontal bzw. vertikal sowohl in die darüber als auch in die darunter liegende Etage verlegt werden.

ES Canalización con Multifuoco®

A través de un simple sistema de canalización, realizado con tubos flexibles de diámetro reducido, es posible calentar también otros ambientes de la casa. La difusión del calor es aún más confortable y uniforme, ya que se efectúa por varios puntos, con bocas dotadas de regulación de flujo. La fácil colocación de los conductos de canalización permite realizar un sistema de calefacción versátil, en ambientes adyacentes o canalizables hasta 12 m. La canalización puede realizarse horizontal o verticalmente, ya sea sobre el piso superior o el inferior.



Flexible Ducts
Ø75 mm



Design ed emozione del fuoco

Design and the charm of the flame
Design et émotion du feu
Feuer - Design und Emotionen
El diseño y la emoción del fuego

Design ricercato, estrema attenzione per i dettagli. È la passione per il fuoco che ci guida nello sviluppo dei nostri prodotti. L'estetica esprime la nostra originalità, la bellezza della fiamma genera lo stupore per la magia del fuoco a legna. Un tutt'uno che affascina e incanta alla luce che brilla e che innalzandosi sa disegnare uno spettacolo nel focolare. La Maiolica che riveste le stufe a legna è l'elemento che arricchisce con artigiana originalità le stufe di Piazzetta.

EN Refined design and attention to detail. Our passion for the flame is the driving force behind our products. Our products have an original aesthetic and the beauty of the flame adds the finishing touch. This is a winning combination that sets the stage for the spectacle in the furnace. The Majolica cladding on our wood-burning stoves brings out the beauty and originality of Piazzetta stoves.

FR Design recherché et attention extrême accordée aux détails. C'est la passion du feu qui nous guide dans le développement de nos produits. L'esthétique exprime notre originalité et la beauté de la flamme génère la stupeur par la magie du feu de bois. Un tout qui fascine et enchante grâce aux flammes qui illuminent le foyer et y dessinent de véritables spectacles. La faïence qui les recouvre est l'élément qui enrichit avec une originalité artisanale les poêles de la marque Piazzetta.

DE Ausgesuchtes Design, große Liebe zum Detail. Es ist die Leidenschaft für das Feuer, das uns in der Entwicklung unserer Produkte antreibt. Die Ästhetik bringt unsere Originalität zum Ausdruck, die Schönheit der Flamme löst Erstaunen über den Zauber von Holzfeuer in uns aus. Ein faszinierendes großes Ganzes im Angesicht eines aufflammenden Lichtes, das ein mitreißendes Schauspiel im Feuerraum erzeugt. Die den Holzofen verkleidende Majolika bereichert die Öfen von Piazzetta mit origineller Handwerksarbeit.

ES Diseño refinado, atención extrema a los detalles. Es la pasión por el fuego la que nos guía en el desarrollo de nuestros productos. La estética expresa nuestra originalidad, la belleza de la llama genera el estupor por la magia del fuego de leña. Un todo que cautiva y hechiza a la luz que brilla y que a medida que crece va diseñando todo un espectáculo en el hogar. La mayólica que reviste las estufas de leña es el elemento que enriquece las estufas de Piazzetta con originalidad artesanal.



HSS, Heat Storage System

Con l'innovativo sistema Hss il piacere del calore si prolunga per ore anche dopo lo spegnimento del fuoco. Puoi anche addormentarti tranquillamente sul divano. Esaurita la carica di legna la tua stufa continuerà a riscaldare l'ambiente per irraggiamento e al tuo risveglio sarai ancora avvolto dal tepore.

EN With the innovative HSS system, the warmth remains even hours after the flame has gone out. You can also fall asleep on the sofa. Once the wood fuel has been burnt the stove continues to heat the room via heat radiation, allowing you to wake up to warmth.

FR Grâce à l'innovant système HSS, le plaisir de la chaleur se prolonge plusieurs heures après l'extinction du feu. Vous pouvez vous endormir tranquillement sur le canapé. Une fois tout le bois est brûlé, votre poêle continuera de chauffer par rayonnement et vous vous réveillerez encore entouré d'une douce chaleur.

> 10h

Rilascio del calore

EN Heat Release

FR Diffusion de la chaleur

DE Wärmefreisetzung

ES Emisión del calor





DE Mit dem innovativen HSS-System hält die angenehme Wärme auch Stunden nach dem Erlöschen des Feuers an. Sie können sogar ganz beruhigt auf dem Sofa einschlafen. Nachdem die Holzladung aufgebraucht ist, heizt der Ofen den Raum durch Strahlungswärme weiter und Sie wachen in einem warmen Raum wieder auf.

ES Con el innovador sistema Hss el placer del calor se prolonga durante horas incluso después de que se ha apagado el fuego. Podrás dormir tranquilamente en el sofá; una vez agotada la carga de leña, la estufa seguirá calentando el ambiente por irradiación, y al despertar estarás aún envuelto en la tibieza.

Il comfort di un riscaldamento ad accumulo HSS

HEAT STORAGE
SYSTEM

Installabile sulle nuove stufe a legna, l'esclusivo sistema di accumulo, Heat Storage System HSS è in grado di rilasciare calore per molte ore dopo lo spegnimento del fuoco. HSS è un kit optional e può essere installato anche in un secondo momento nelle stufe predisposte.

EN The comfort of a Heat Storage System

The exclusive new Heat Storage System (HSS) can be installed on our new wood-burning stoves. It releases heat for many hours after the flame has gone out. HSS is an optional kit, which on compatible stoves may be installed later on.

FR Le confort du chauffage à accumulation HSS

Installable dans les nouveaux poêles à bois, le système exclusif d'accumulation Heat Storage System HSS permet de diffuser la chaleur encore longtemps après l'extinction du feu. Le système HSS est en option et peut être installé dans un second temps sur les poêles prééquipés.

DE Der Komfort eines HSS-Wärmespeichers

Das exklusive Wärmespeichersystem Heat Storage System HSS für die neuen Holzöfen gibt noch Stunden nach dem Erlöschen des Feuers Wärme ab. HSS ist ein optionales Kit und kann auch im Nachhinein an dafür ausgelegten Öfen installiert werden.

ES El confort de la calefacción por acumulación HSS

El exclusivo sistema de acumulación Heat Storage System HSS, para la instalación en las nuevas estufas de leña, emite calor varias horas después de la extinción fuego. El HSS es un kit opcional que puede instalarse también en una fase sucesiva en las estufas compatibles.

Combustione e Accumulo¹ - Restituzione del calore²

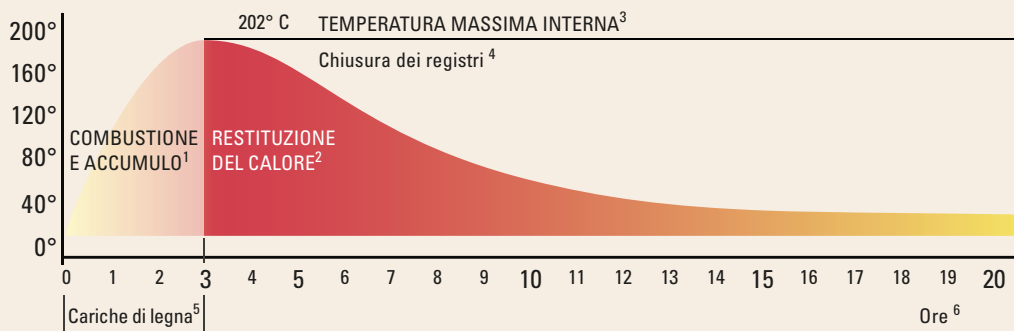

¹ **EN** Combustion and Heat Storage

¹ **FR** Combustion et accumulation

¹ **DE** Verbrennung und Speicherung

¹ **ES** Combustión y acumulación

² **EN** Heat recovery

² **FR** Restitution de la chaleur

² **DE** Wärmeabgabe

² **ES** Restitución del calor

³ **EN** Maximum internal temperature

³ **FR** Température intérieure maximale

³ **DE** Maximale Innentemperatur

³ **ES** Temperatura máxima interna

⁴ **EN** Register convection air closure

⁴ **FR** Fermeture sortie our convection

⁴ **DE** Schließung der Schieber

⁴ **ES** Cierre de los registros

⁵ **EN** Wood loads

⁵ **FR** Chargements de bois

⁵ **DE** Holzfüllungen

⁵ **ES** Cargas de leña

⁶ **EN** Hours

⁶ **FR** Heures

⁶ **DE** Stunden

⁶ **ES** Horas

Una stufa a legna
Piazzetta può riscaldare per
convezione naturale, con
l'esclusivo sistema
Multifuoco® o Multifuoco®
Plus, anche con la gestione
elettronica della fiamma BCS,
e, se predisposta, con il
sistema di accumulo HSS.

EN A Piazzetta wood-burning stove can provide heat via natural convection, and with the exclusive Multifuoco® or Multifuoco® Plus systems, also via BCS electronic flame control, and if compatible, via the Heat Storage System.

FR Une poêle à bois Piazzetta peut chauffer par convection naturelle, avec le système exclusif Multifuoco® ou Multifuoco® Plus, ainsi qu'avec la gestion électronique de la flamme BCS, et, s'il est prééquipé, avec le système d'accumulation HSS.

DE Ein Piazzetta Holzofen kann über natürliche Konvektion, mit dem exklusiven Multifuoco® oder Multifuoco® Plus System heizen, sowie mit der elektronischen Flammensteuerung BCS und dem HSS-Speichersystem (sofern dafür ausgelegt) heizen.

ES Una estufa de leña Piazzetta puede calentar por convección natural, con el exclusivo sistema Multifuoco® o Multifuoco® Plus, aun con gestión electrónica de la llama BCS, y, si es compatible, con el sistema de acumulación HSS.

Sistema di accumulo HSS.

EN Storage System HSS.
FR Chauffage à accumulation HSS.
DE HSS-Wärmespeicher.
ES Calefacción por acumulación HSS.

Uscita fumi.

EN Flue exit.
FR Sortie des fumées.
DE Rauchausgang.
ES Salida de humo.

Rivestimento in Maiolica.

EN Cladding made of Majolica.
FR Revêtement en Faïence.
DE Verkleidung aus Majolika.
ES Revestimiento de Mayólica.

Aria comburente.

EN Combustion air.
FR Air comburant.
DE Verbrennungsluft.
ES Aire comburente.

Entrata dell'aria comburente.

EN Combustion air intake.
FR Entrée de l'air comburant.
DE Eintritt der Verbrennungsluft.
ES Entrada del aire comburente.

Uscita aria calda in ambiente.

EN Hot air vent.
FR Sortie d'air chaud dans la pièce.
DE Austritt der Warmluft in den Raum.
ES Salida del aire caliente al ambiente.

Uscita aria per canalizzazione.

EN Ducting outlet.
FR Sortie d'air pour canalisation.
DE Luftaustritt zur Kanalisierung.
ES Salida del aire para la canalización.



I vantaggi di un focolare Ermetico

The advantages of an Airtight firebox
Les avantages d'un foyer étanche
Die Vorteile eines raumluftunabhängigen Heizeinsatzes
Las ventajas de un hogar hermético

Benessere ideale

La soluzione giusta per ogni ambiente



Scegliere una stufa con focolare ermetico significa non impiegare l'ossigeno dell'ambiente per la combustione. Scelta ideale per le case passive, è efficace anche nelle case tradizionali.

EN Ideal comfort

The right solution for every room.

Choosing a stove with a airtight firebox means not consuming oxygen in the room for combustion. It is the ideal solution for passive homes and is also effective in conventional homes.

FR Le bien-être idéal

La solution adaptée à toutes les pièces.

Choisir un poêle à foyer étanche, c'est ne pas utiliser l'oxygène de la pièce pour la combustion. Choix idéal pour les maisons passives, il est aussi efficace dans les maisons traditionnelles.

DE Perfektes Wohlbefinden

Die richtige Lösung für jeden Raum.

Die Wahl eines Ofens mit raumluftunabhängigem Heizeinsatz heißt, nicht den Umgebungssauerstoff für die Verbrennung zu nutzen. Ideal für Passivhäuser, geeignet auch für traditionelle Wohnhäuser.

ES Bienestar ideal

La solución ideal para cualquier ambiente.

Elegir una estufa con hogar hermético significa no utilizar el oxígeno del ambiente para la combustión. La solución ideal para las casas pasivas, eficaz también en las casas tradicionales.

Migliora il comfort

L'aria viene prelevata dall'esterno



Con il focolare ermetico l'aria necessaria per la combustione viene prelevata direttamente dall'esterno. Non è più necessario realizzare le antiestetiche bocchette di aerazione nelle pareti esterne.

EN Improves comfort Air is drawn from the outside.

With the airtight firebox the air needed for the combustion is drawn in directly from the outside. There is no longer any need for ugly air vents in exterior walls.

FR Il améliore le confort L'air est prélevé à l'extérieur.

Avec le foyer étanche, l'air nécessaire à la combustion est prélevé directement à l'extérieur. Il n'est plus nécessaire de réaliser des bouches d'aération peu esthétiques dans les murs extérieurs.

DE Verbessertes Komfort Die Luft wird von außen entnommen.

Mit dem raumluftunabhängigen Heizeinsatz wird die Verbrennungsluft direkt von außen zugeführt. Unästhetische Belüftungsöffnungen werden daher überflüssig.

ES Mejora el confort El aire se toma del exterior.

Con el hogar hermético, el aire requerido para la combustión se toma directamente del exterior. Ya no es necesario realizar las antiestéticas boquillas de ventilación en las paredes externas.



BCS, la comodità di una gestione elettronica

- Regolazione automatica della fiamma a legna con controllo elettronico da telecomando.
- Combustione perfetta, elevati rendimenti, ridotte emissioni in atmosfera, risparmio di combustibile.
- Possibilità di prolungare al massimo la durata di una carica di legna, con una gestione automatica.
- Automatic wood flame regulation with electronic remote control.
- Perfect combustion, improved performance, reduced emissions, fuel savings.
- Ability to prolong the duration of one wood load to the maximum, with automatic control.
- Régulation automatique de la flamme avec contrôle électronique par télécommande.
- Combustion parfaite, hauts rendements, émissions atmosphériques réduites, économie de combustible.
- Possibilité de prolonger au maximum la durée d'un chargement de bois par une gestion automatique.



**BCS, the convenience of
electronic control
BCS, le confort de la gestion
électronique
BCS, die Bequemlichkeit einer
elektronischen Steuerung
BCS, la comodidad de una gestión
electrónica**

- **Automatische
Flammenregelung mit
elektronischer
Fernsteuerung.**
- **Perfekte Verbrennung, hohe
Leistungen, Senkung der
CO2-Emissionen, merklliche
Brennstoffeinsparung.**
- **Die Dauer einer Holzladung
kann über die automatische
Verwaltung auf Maximum
verlängert werden.**
- **Regulación automática de
la llama de leña con control
electrónico mediante mando
a distancia.**
- **Combustión perfecta, alto
rendimiento, bajas
emisiones a la atmósfera,
ahorro de combustible.**
- **Posibilidad de maximizar
la duración de una carga de
leña, con una gestión
automática.**



BCS, Burn Control System

Gestione della fiamma

Automatica o assistita.

Impostata da telecomando la temperatura desiderata in ambiente, il sistema BCS modula in continuo la potenza della fiamma, regolando l'apertura della valvola comburente. Il controllo può essere automatico o assistito.

EN Flame control. Automatic or assisted.
The desired room temperature is set using the remote control, the BCS continuously modulates the flame power, adjusting the opening of the combustion valve. Automatic or assisted control.

DE Flammensteuerung. Im automatischen oder unterstützten Modus.
Nach dem Einstellen der gewünschten Temperatur an der Fernsteuerung sorgt das BCS-System anhand der Öffnungsregelung des Verbrennungsluftventils zur Steuerung der Flammenleistung.

FR Gestion de la flamme. Automatique ou assistée.
Une fois la température réglée depuis la télécommande, le système BCS module en continu la puissance de la flamme, en réglant l'ouverture de la vanne d'air comburant. Le contrôle peut être automatique ou assisté.

ES Gestión de la llama. Automática o asistida.
Al configurar la temperatura ambiente deseada con el mando a distancia, el sistema BCS modula continuamente la potencia de la llama regulando la apertura de la válvula comburente. El control puede ser automático o asistido.



Comfort attivo

Controllo automatico temperatura ambiente.

La sonda di rilevazione della temperatura posta nel telecomando del BCS dialoga costantemente con la centralina elettronica della stufa, variando l'intensità della fiamma in base alla necessità dell'ambiente.

EN Active comfort Automatic room temperature control.
The temperature sensor incorporated in the BCS remote control communicates continuously with the stove's electronic control unit, varying the intensity of the flame based on requirements of the room.

DE Aktiver Komfort Automatische Kontrolle der Raumtemperatur.
Der Temperaturmessfühler in der Fernsteuerung des BCS steht im konstanten Dialog mit der Steuerung des Ofens und regelt die Intensität der Flamme auf Grundlage des Raumbedarfs.

FR Confort actif Contrôle automatique de la température ambiante.
La sonde de température située dans la télécommande du BCS dialogue en continu avec la centrale électronique du poêle, modifiant la puissance de la flamme en fonction des besoins de la pièce.

ES Confort activo Control automático de la temperatura ambiente.
El diálogo continuo entre la sonda de detección de la temperatura en el mando a distancia del BCS y la unidad de control electrónica de la estufa, regula la intensidad de la llama según se requiera.





Avviso di ricarica legna

Per sapere quando ricaricare la legna.

Un segnale acustico e un messaggio sul telecomando, avvertono l'utente quando ricaricare la legna per mantenere vivo il fuoco.

EN Reload wood notification. Informs you when to load more wood.

An acoustic signal and a message on the remote control advises the user when to reload to maintain the fire optimal.

DE Nachlade-Meldung. Wenn Holz nachgeladen werden soll.

Ein Audiosignal und eine Anzeige auf dem Display der Fernbedienung weisen den Benutzer auf die Nachladung zum Erhalten der Flamme hin.

FR Signal de ravitaillement en bois. Pour savoir quand remettre du bois.

Un signal sonore et un message sur la télécommande avertissent l'utilisateur quand il doit remettre de bois.

ES Aviso de recarga de leña. Para saber cuándo recargar la leña.

Una señal acústica y un mensaje en el mando a distancia informan al usuario cuándo recargar la leña para mantener vivo el fuego.



Funzione Eco

Risparmio di legna fino al 50%.

Tecnologia ideale per le case passive nelle quali è necessario mantenere l'equilibrio tra ambiente esterno e interno e calibrare l'aerazione.

EN Eco function.

Uses up to 50% less wood.

This is the ideal technology for passive houses, in which the balance between the interior and exterior must be maintained with calibrated air flow.

DE Öko-Betrieb. Bis zu 50%

Holzeinsparung.

Die optimale Technologie für Passivhäuser, in denen das Gleichgewicht von Außen- und Innenraum bewahrt und die Belüftung kontrolliert werden muss.

FR Fonction Éco.

Économie de bois jusqu'à 50 %.

Technologie idéale pour les maisons passives où il faut préserver l'équilibre entre l'extérieur et l'intérieur et calibrer l'aération.

ES Función Eco.

Ahorro de leña de hasta el 50 %.

Tecnología ideal para las casas pasivas en las que hay que mantener el equilibrio entre ambiente exterior e interior y calibrar la ventilación.



Funzione Notte

Tempore prolungato.

È possibile impostare la stufa alla sua minima potenza di funzionamento, per la massima durata della legna e la maggior permanenza delle braci.

EN Night Function.

Prolonged warmth.

The stove can be set to minimum operating power for maximum fuel duration and increased ember life.

DE Nacht-Funktion.

Anhaltende Wärme.

Der Ofen kann auf seine Mindestbetriebsleistung eingestellt werden, für eine maximale Brenndauer und Gluterhaltung.

FR Fonction Nuit.

Chaleur prolongée.

Il est possible de régler le poêle à sa puissance minimale, pour garantir une durée de combustion maxi et conserver les braises le plus longtemps possible.

ES Función Noche.

Tibieza prolongada.

Se puede configurar la estufa a la potencia mínima de funcionamiento, para maximizar la duración de la leña y optimizar la permanencia de las brasas.

Maiolica artigianale

L'arte della lavorazione artigianale della Maiolica ci consente di realizzare oggetti unici. La tecnologia delle migliori stufe a legna incontra una materia che ancora si plasma a mano: la Maiolica. Solo pezzi unici che, colati negli stampi, asciugati lentamente e verniciati a mano, richiedono 15 giorni di tempo per la lavorazione.

Rivestimenti in Maiolica in oltre 40 colori e differenti finiture vengono realizzati in azienda, nella più grande fabbrica europea di produzione di Maiolica del settore.

EN Handcrafted Majolica

The art of Majolica handcrafting allows us to create unique objects. The best in wood-burning stove technology encounters a material that is still conjured manually: Majolica. Only single pieces are produced; after being cast in moulds, dried slowly and coated by hand, they require 15 days of hand crafting. Majolica claddings in over 40 colours and different finishes are made within the company, in Europe's largest Majolica production factory in the industry.

FR Faïence artisanale

L'art du façonnage artisanal de la Faïence nous permet de réaliser des objets uniques. La technologie des poêles à pellet rencontre une matière que l'on modèle encore à la main : la Faïence. Des pièces uniques moulées, séchées lentement et peintes à la main qui exigent 15 jours de travail pour leur réalisation. Des revêtements en Faïence dans plus de 40 coloris et dans de nombreuses finitions sont réalisés sur place, dans la plus grande usine européenne du secteur produisant de la Faïence.





DE Handwerkliche Fertigung

Die Kunst der handwerklichen Bearbeitung von Majolika ermöglicht es, einzigartige Produkte zu kreieren. Neueste Technologie in Holzöfen trifft auf ein Material, das noch von Hand geformt wird: Majolika. Es entstehen in einem 15-tägigen Prozess einzigartige Stücke, die in Formen gegossen, langsam getrocknet und manuell glasiert werden. Majolika-Verkleidungen in über 40 Farben und Finishes in der größten europ. Majolika-Manufaktur in unserem Bereich.

ES Mayólica artesanal

El arte de la elaboración artesanal de la Mayólica nos permite realizar objetos únicos. La tecnología de las mejores estufas de pellets emplea una materia que se plasma a mano: la mayólica. Sólo piezas únicas que, coladas en los moldes, secadas lentamente y pintadas a mano, requieren 15 días para la elaboración. Revestimientos de Mayólica en más de 40 colores y distintos acabados se realizan en la empresa, en la mayor fábrica europea de producción de Mayólica del sector.

Gamma Stufe a Legna

Wood-burning stove range
Gamme de poêles à bois
Holzofen-Serie
Gama de estufas de leña

Piazzetta offre la più vasta gamma di stufe a legna caratterizzate dalla ricercatezza del design e da soluzioni tecniche che offrono massimo comfort d'impiego. Differenti tipologie di prodotto, consentono di riscaldare piccoli e grandi ambienti, anche con sistemi di canalizzazione. Il riscaldamento può essere a convezione naturale, ma anche a ventilazione forzata con l'esclusivo sistema Multifuoco® installabile con un kit. È possibile dotare alcuni modelli con il sistema di accumulo HSS, che rilascia calore molte ore ancora dopo lo spegnimento del fuoco e, per la massima praticità, controllare il fuoco con un sistema a gestione elettronica, da telecomando. Tante soluzioni per garantire, davvero, il massimo piacere del fuoco a legna.

EN Piazzetta offers a vast range of wood-burning stoves characterised by refined design and technical solutions that offer the best in comfort. Different types of products are suitable for heating both small and large spaces, with optional ducting systems. Heating can be achieved via natural convection or forced ventilation using the exclusive Multifuoco® system, installed as a kit. Some models can be fitted with a HSS, which releases heat for many hours after the flame has gone out. For maximum comfort, the flame can be controlled by a electronic control system using a remote control. Many solutions to truly get the most from your wood fire.

FR Piazzetta offre la plus grande gamme de poêles à bois, caractérisés par un design recherché et des solutions techniques offrant un confort d'utilisation maximal. Les différents types de produit permettent de chauffer les petits et les grands espaces, également avec des systèmes de canalisation. Le chauffage peut être à convection naturel ou à ventilation forcée en installant le kit Multifuoco®. Certains modèles peuvent être dotés du système d'accumulation HSS, qui délivre de la chaleur encore plusieurs heures après l'extinction du feu et permet le contrôle du feu avec un système de gestion électronique par télécommande, pour une commodité maximale. Autant de solutions pour offrir vraiment le plaisir du feu de bois.

DE Piazzetta bietet die größte Auswahl an Holzöfen mit ausgesuchtem Design und technischen Lösungen mit maximalem Einsatzkomfort an. Verschiedene Produkttypologien ermöglichen das Beheizen von kleinen und großen Räumen, auch über ein Kanalsystem. Die Erwärmung kann über natürliche Konvektion oder über die Installation des exklusiven Multifuoco® Systems, einem Gebläselüftungs-Kit, erfolgen. Einige Modelle können auch mit dem Wärmespeichersystem HSS ausgerüstet werden, das noch Stunden nach Erlöschen der Flamme Wärme abgibt. Zuletzt kann das Feuer mit einem elektronischen Steuersystem per Fernbedienung kontrolliert werden und sorgt damit für maximale Bequemlichkeit. Viele Lösungen für den höchsten Genuss eines Holzfeuers.

ES Piazzetta ofrece la más amplia gama de estufas de leña caracterizadas por un diseño refinado y soluciones técnicas que proporcionan la máxima comodidad de uso. Distintos tipos de producto permiten calentar ambientes grandes y pequeños, y ofrecen incluso sistemas de canalización. La calefacción puede realizarse por convección natural o por ventilación forzada con el exclusivo sistema Multifuoco® que puede instalarse con un kit. Algunos modelos pueden equiparse con el sistema de acumulación HSS, que emite calor durante varias horas tras la extinción del fuego y, para el máximo confort, controlar el fuego con un sistema de gestión, mediante mando a distancia. Tantas soluciones para garantizar el máximo placer del fuego de leña.



Stufe Ermetiche.
Massimo comfort d'ambiente
anche per case passive.

EN Airtight stoves
Maximum comfort even for
passive homes.

FR Poêles étanches
Confort ambiant maximal, même
pour les maisons passives.

DE Raumluftunabhängige Öfen
Maximaler Raumkomfort auch für
Passivhäuser.

ES Estufas herméticas
Máximo confort ambiental
también para casas pasivas.



Stufe a Convezione Naturale.
La propagazione naturale del
calore per irraggiamento.

EN Natural Convection Stoves
Natural heat distribution via
radiation.

FR Poêles à convection naturelle
La propagation naturelle de la
chaleur par rayonnement.

DE Ofen mit natürlicher Konvektion
Die natürliche Wärmeverteilung
durch Strahlungswärme.

ES Estufas de convección natural
La propagación natural del calor
por irradiación.



Stufe Multifuoco® System.
L'esclusivo sistema di
ventilazione forzata brevettato.

EN Multifuoco® System Stoves
The exclusive patented forced
ventilation system.

FR Poêles Multifuoco® System
Le système exclusif de ventilation
forcée breveté.

DE Öfen mit Multifuoco® System
Die exklusive patentierte
Gebläselüftung.

ES Estufas Multifuoco® System
El exclusivo sistema de
ventilación forzada patentado.



Stufe Multifuoco® System Plus.
L'evoluzione del sistema
Multifuoco® per le stufe a legna.

EN Multifuoco® System Plus Stoves
The new Multifuoco® system for
wood-burning stoves.

FR Poêles Multifuoco® System Plus
L'évolution du système
Multifuoco® pour poêles à bois.

DE Öfen mit Multifuoco® System Plus
Die Evolution des Multifuoco®
Systems für Holzöfen.

ES Estufas Multifuoco® System Plus
Evolución del sistema
Multifuoco® para estufas de leña.



Stufe Burn Control System.
Massima efficienza del fuoco a
legna gestito da telecomando.

EN Burn Control System Stoves
Maximum efficiency for wood
burning fire via remote control.

FR Poêles Burn Control System
Rendement maximal du feu de
bois géré par télécommande.

DE Öfen mit Burn Control System
Maximale Effizienz des
Holzfeuers per Fernsteuerung.

ES Estufas Burn Control System
Máxima eficiencia del fuego de
leña con mando a distancia.



Stufe Heat Storage System.
Sistema che prolunga il calore
dopo lo spegnimento del fuoco.

EN Heat Storage System Stoves
A system that releases heat after
the flame has gone out.

FR Poêles Heat Storage System
Système qui prolonge la chaleur
après l'extinction du feu.

DE Öfen mit Heat Storage System
System zur Wärmehaltung
nach Erlöschen des Feuers.

ES Estufas Heat Storage System
Sistema que prolonga el calor tras
la extinción del fuego.

Stile e arredo

Forme ricercate, stile ed espressione di contemporaneità per questa famiglia di stufe a legna pensate per riscaldare e rendere esclusivo ogni ambiente. La Maiolica riveste interamente la superficie della stufa, anche nella parte posteriore, consentendo l'installazione in centro stanza. Inoltre, grazie a un basamento a scomparsa, è possibile ruotare la stufa, e quindi orientare la visione del fuoco, laddove ci si trova nell'ambiente. Sono disponibili anche versioni BCS con controllo elettronico della fiamma, e con sistema di accumulo HSS.

EN Style and furnishing

Refined shapes and contemporary styles for this range of wood-burning stoves designed to heat and embellish any space. The entire stove is wrapped with an eye-catching Majolica cladding, thus allowing for centre of the room installation, making it not only the focus point of the room but also a versatile viewing centre piece. Thanks to a concealed base, the stove can also be rotated to direct the view of the flame towards wherever you are sitting in the room. Also available in versions with BCS electronic flame control and HSS.

FR Style et décoration d'intérieur

Formes recherchées, style et expression de la modernité sont les maîtres mots de cette famille de poêles à bois imaginés pour réchauffer et rendre unique n'importe quel espace. La faïence recouvre toute la surface du poêle, même à l'arrière, ce qui permet de l'installer au centre de la pièce. En outre, une base invisible permet de faire tourner le poêle et donc d'orienter la vision du feu vers l'endroit de la pièce où l'on se trouve. Des versions avec système BCS à contrôle électronique de la flamme et avec système d'accumulation HSS sont aussi disponibles.

DE Stil und Einrichtung

Ausgewählte Formen und moderne Ausdruckskraft in einer Holzofen-Familie zum Heizen, die jedem Ambiente einen exklusiven Charakter verleiht. Die Ofenoberfläche einschließlich Rückseite ist mit Majolika-Kacheln verkleidet, wodurch eine Installation in der Raummitte möglich ist. Außerdem ist der Ofen dank des versenkbaren Sockels drehbar, wodurch die Sicht auf das Feuer jeweils auf den jeweiligen Aufenthaltspunkt im Raum ausgerichtet werden kann. Erhältlich auch in den Versionen mit elektronischer Flammensteuerung (BCS) und HSS-Wärmespeichersystem.

ES Estilo y decoración

Formas refinadas, estilo y expresión de modernidad para esta familia de estufas de leña pensadas para calentar y dar un toque exclusivo a cualquier ambiente. La mayólica reviste enteramente la superficie de la estufa, incluso en la parte posterior, de manera tal que pueda instalarse en el centro de la habitación. Además, gracias a una base ocultable, es posible girar la estufa y orientar así la visión del fuego hacia el lugar que se desee. También hay disponibles versiones BCS con control electrónico de la llama y con sistema de acumulación HSS.



Rivolgì a te il fuoco



Grazie a un dispositivo alla base, ruotando la stufa puoi rivolgere verso di te l'unicità di ogni istante della fiamma. Mettiti in prima fila e goditi al meglio questo meraviglioso spettacolo.

EN Turn the fire towards you

Thanks to a device at the base, you can rotate the stove to face you so as not to miss a single moment of the flames. Put yourself in the front row and enjoy the view.

FR Tournez le feu vers vous

Grâce à un dispositif à sa base, vous pouvez tourner le poêle vers vous et profiter de la flamme à chaque instant. Asseyez-vous et profitez de ce merveilleux spectacle.

DE Das Feuer wendet sich Ihnen zu

Der Ofen ist dank einer Vorrichtung im Sockel drehbar und sorgt somit für ein Rundumerlebnis der Flamme. Genießen Sie das Schauspiel von ihrem Platz in der ersten Reihe aus.

ES Controla la dirección del fuego

El dispositivo en la base permite controlar la dirección de la llama en cada instante, girando la estufa. Ponte en primera fila y disfruta de este maravilloso espectáculo.



Massima efficienza



La progettazione di un focolare di ultima generazione consente di ottenere alti rendimenti. Elevata resa termica e calore in ambiente con un ridotto carico di legna.

EN **Maximum efficiency**

The design of the new generation firebox offers excellent levels of efficiency. High heat output and warmth in the room with reduced wood consumption.

FR **Efficacité maximale**

La conception d'un foyer de dernière génération permet d'obtenir des rendements élevés. Rendement thermique élevé et chaleur dans la pièce avec un chargement en bois réduit.

DE **Maximale Effizienz**

Der moderne Heizeinsatz gewährleistet die Erzielung hoher Leistungswerte. Eine hohe Wärmeleistung und wohlige Wärme des Raums mit einer verringerten Holzfüllung.

ES **Máxima eficiencia**

El alto rendimiento se obtiene gracias al diseño de un hogar de última generación. Un alto rendimiento térmico y un fuerte calor en el ambiente con una baja carga de leña.



BCS Gestione elettronica



Massimo comfort di impiego grazie alla regolazione automatica della fiamma a legna, gestita con controllo elettronico da telecomando. Combustione perfetta, elevati rendimenti.

EN **BCS electronic control**

Maximum comfort thanks to automatic wood flame regulation, electronically controlled via remote control. Perfect combustion, high efficiency.

DE **BCS Elektronische Steuerung**

Maximale Bedienerfreundlichkeit dank der automatischen Flammenregelung, die über eine elektronischer Fernbedienung gesteuert wird. Perfekte Verbrennung, hohe Leistungswerte.

FR **BCS Gestion électronique**

Confort d'utilisation grâce au réglage automatique de la flamme, géré avec contrôle électronique par télécommande. Une combustion parfaite, hauts rendements.

ES **Gestión electrónica BCS**

Máximo confort gracias a la regulación automática de la llama con un control electrónico mediante mando a distancia. Combustión perfecta, alto rendimiento.



Ampia gamma e design



Una vasta scelta di modelli, differenti soluzioni di stile e modalità di impiego che consentono anche di scegliere l'altezza di visione del fuoco per godere pienamente lo spettacolo.

EN **Broad range and design**

An extensive assortment of models, different style solutions and modes of use which even allow for choosing the flame viewing height to fully relish the spectacle.

DE **Große Auswahl und exklusives Design**

Ein umfassendes Modellangebot mit unterschiedlichen Stillösungen und Einsatzarten sowie Auswahl der Sichthöhe, damit Sie das Flammenschauspiel voll genießen können.

FR **Design et gamme étendue**

Un large choix de modèles, solutions stylistiques et modes d'utilisation qui permettent en outre de choisir la hauteur de vision du feu pour profiter au maximum du spectacle.

ES **Amplia gama y diseño**

Un vasto surtido de modelos, distintas propuestas en cuanto a estilo y modo de uso que permiten elegir la altura de visión del fuego para disfrutar plenamente del espectáculo.



E924

Design essenziale e semplicità delle forme per inserirsi in differenti soluzioni di arredo. Stufa a legna rivestita in Maiolica. Il vetro curvo a filo porta offre massima visione del fuoco e un design esclusivo. Disponibile anche in versione con sistema BCS.

EN Clean design and simple forms blend in with different interior schemes. Wood-burning stoves dressed with Majolica. The flush curved glass door offers a clear view of the flame and an exclusive design. Also available in a BCS version.

DE Minimalistisches Design und schlichte Formen fügen sich in verschiedene Einrichtungslösungen ein. Holzofen mit Majolika-Verkleidung. Das bündig gebogene Glas bietet eine maximale Sicht auf das Feuer und ein exklusives Design. Auch mit BCS-System erhältlich.

FR Design essentiel et simplicité des formes pour s'intégrer dans différentes décorations d'intérieur. Poêle à bois avec habillage en faïence. La vitre incurvée affleurante offre une vision maximale du feu et un design exclusif. Disponible également en version avec BCS.

ES Diseño esencial y sencillez en las formas para adaptarse a distintas opciones de decoración. Estufa de leña revestida de mayólica. El vidrio curvado a ras de la puerta ofrece la máxima visibilidad del fuego. Disponible también en versión con sistema BCS.

COLORI - COLOURS

Bianco, Ardesia, Grigio Cerato, Nero Opaco, Rosso Lava, Giallo Acceso

cm 46 x 46 x 114

→ Specifications and colours P.150



7,2 kW
up to 210 m³



E924 H

Nuove proporzioni rendono preziosa ed elegante questa stufa a legna caratterizzata da un vetro curvo a filo porta per la massima visione del fuoco. Interamente rivestita in Maiolica. Disponibile anche nella versione con sistema di controllo elettronico della fiamma BCS.

EN New proportions make this wood-burning stove elegant and beautiful. The flush curved glass door offers a clear view of the flame. Completely dressed with Majolica. Also available in a BCS version.

DE Neue Proportionen verleihen diesem Holzofen mit bündig gebogener Glastür und maximaler Sicht auf das Feuer sein elegantes Design. Komplett-Verkleidung aus Majolika. Auch als Version mit elektronischer Flammensteuerung BCS erhältlich.

FR Les nouvelles proportions de ce poêle à bois caractérisé par une vitre incurvée affleurante pour une vision maximale du feu lui confèrent un look précieux et élégant. Entièrement revêtu de faïence. Disponible également avec contrôle électronique de la flamme BCS.

ES Las nuevas proporciones dan elegancia y valor a esta estufa de leña caracterizada por un vidrio curvado a ras de la puerta para la máxima visibilidad del fuego. Totalmente revestida de mayólica. Disponible también en versión con sistema de control electrónico de la llama BCS.

COLORI - COLOURS

Bianco, Ardesia, Grigio Cerato, Nero Opaco, Rosso Lava, Giallo Acceso

cm 46 x 46 x 138

→ Specifications and colours P.152



7,2 kW
up to 210 m³



E924 M

Gentile nelle sue forme, ideale anche per essere collocata al centro dell'ambiente. Completamente rivestita in Maiolica. Vetro curvo a filo porta per una massima visione del fuoco. Anche in versione con sistema BCS.

EN With its gentle forms, this stove can also be placed in the centre of the room. Completely dressed with Majolica. The flush curved glass door offers a clear view of the flame. Also available in a BCS version.

DE Mit seinen abgerundeten Formen ist er ideal auch für die Positionierung in der Raummitte. Der komplett mit Majolika verkleidete. Die bündig gebogene Glastür bietet eine maximale Sicht auf das Feuer. Auch mit BCS-System erhältlich.

FR Poêle aux formes douces, idéal pour être placé au centre de la pièce. Entièrement revêtu de faïence. Vitre incurvée affleurante pour une vision maximale du feu. Également disponible en version avec système BCS.

ES Gentil en sus formas, ideal también para colocarse en el centro del ambiente. Esta estufa de leña, totalmente revestida de mayólica. Vidrio curvado a ras de la puerta para la máxima visibilidad del fuego. También en versión con sistema BCS.

COLORI - COLOURS

Bianco, Ardesia, Grigio Cerato, Nero Opaco, Rosso Lava, Giallo Acceso

cm 52 x 52 x 115

→ Specifications and colours P.152 - 153



7,2 kW
up to 210 m³



CIRCLE

Design originale e accattivante per una stufa a legna rivestita in Maiolica. Vetro curvo a filo porta per una massima visione del fuoco. Piedini removibili. Anche in versione con sistema di gestione elettronica della fiamma BCS.

EN With its original and captivating design, this wood-burning stove dressed with Majolica. Flush curved glass door for a clear view of the flame. Removable feet. Also available in a BCS version.

DE Der Holzofen mit originellem und anziehendem Design ist komplett mit Majolika. Die bündig gebogene Glastür bietet eine maximale Sicht auf das Feuer. Entfernbar Füße. Auch mit elektronischer BCS Flammensteuerung erhältlich.

FR Design original et séduisant pour ce poêle à bois avec habillage en faïence. Vitre incurvée affleurante pour une vision maximale du feu. Pieds amovibles. Également disponible avec système de gestion électronique de la flamme BCS.

ES Diseño original y cautivador para una estufa de leña revestida de mayólica. Vidrio curvado a ras de la puerta para la máxima visibilidad del fuego. Pies desmontables. También en versión con sistema de gestión electrónica de la llama BCS.

COLORI - COLOURS

Bianco, Ardesia, Grigio Cerato, Rosso Lava. Bicolore - two-colour versions: **Bianco Grigio/Terra Cotta, Bianco/Ardesia**

cm 49 x 49 x 122

→ Specifications and colours P.148 - 149



7,2 kW
up to 210 m³





E924 A

Originale posizione del focolare, rialzato, che denota il particolare design di questa piacevole stufa a legna. Rivestimento in Maiolica. Vetro curvo a filo porta per una massima visione del fuoco. Disponibile anche in versione con sistema BCS.

EN With its original raised firebox position this is a lovely wood-burning stove. Dressed with Majolica. The flush curved glass door offers a clear view of the flame. Also available in a BCS version.

DE Die originelle leicht erhöhte Position der Feuerschale bestimmt das besondere Design dieses angenehmen Holzofens. Majolika-Verkleidung. Das bündig gebogene Glas bietet eine maximale Sicht auf das Feuer. Auch mit BCS-System erhältlich.

FR Cet agréable poêle à bois se distingue par la position originale de son foyer rehaussé. Habillage en faïence. Vitre incurvée affleurante pour une vision maximale du feu. Disponible également en version avec système BCS.

ES Posición original del hogar, elevado, característica del diseño particular de esta agradable estufa de leña. Revestimiento de mayólica. Vidrio curvado a ras de la puerta para la máxima visibilidad del fuego. Disponible también en versión con sistema BCS.

COLORI - COLOURS

Bianco, Ardesia, Grigio Cerato, Nero Opaco, Rosso Lava, Giallo Acceso

cm 46 x 46 x 124

→ Specifications and colours P.150 - 151



7,2 kW
up to 210 m³



E924 A-H

Design con focolare rialzato e predisposizione per il kit HSS. Stufa a legna raffinata e dalle proporzioni decise. Rivestimento in Maiolica. Vetro curvo a filo porta per una massima visione del fuoco. Disponibile anche in versione con sistema BCS.

EN A design with a raised firebox compatible with the HSS kit. This is a refined wood-burning stove with strong proportions. Dressed with Majolica. The flush curved glass door offers a clear view of the flame. Also available in a version with BCS.

DE Design mit leicht erhöhter Feuerschale und Auslegung für HSS-Kit. Raffinierter Holzofen mit soliden Proportionen. Majolika-Verkleidung. Das bündig gebogene Glas bietet eine maximale Sicht auf das Feuer. Auch mit BCS-System erhältlich.

FR Ce poêle à bois raffiné et aux proportions affirmées possède un foyer rehaussé et est prééquipé pour accueillir le kit HSS. Habillage en faïence. Vitre incurvée affleurante pour une vision maximale du feu. Disponible également en version avec système BCS.

ES Diseño con hogar elevado y predisposición para el kit HSS. Estufa de leña refinada y con proporciones resueltas. Revestimiento de mayólica. Vidrio curvado a ras de la puerta para la máxima visibilidad del fuego. Disponible también en versión con sistema BCS.

COLORI - COLOURS

Bianco, Ardesia, Grigio Cerato, Nero Opaco, Rosso Lava, Giallo Acceso

cm 46 x 46 x 162

→ Specifications and colours P.151



7,2 kW
up to 210 m³

Performance e versatilità

Notevole capacità di riscaldamento per questa gamma di stufe a legna dal ricercato design interamente rivestite in Maiolica con elementi di grandi dimensioni. È possibile scegliere come riscaldarsi: a convezione naturale; con Multifuoco® System, anche con il controllo elettronico della fiamma da telecomando BCS; con un sistema di accumulo HSS che riscalda per molte ore dopo lo spegnimento della fiamma. Si potrà pertanto impostare la modalità di riscaldamento preferita in ogni momento. È inoltre possibile canalizzare il calore in altri ambienti.

EN Performance and versatility

This range of wood-burning stoves offers significant heating capacity as well as a refined design entirely fitted with Majolica with intriguing details which exemplify even more the beauty that can be achieved with ceramic and accompanied with large elements. You can choose between different heating methods: natural convection; Multifuoco® System, with BCS remote flame control; with HSS, which provides heat for hours after the flame has gone out. You can select the heating method that suits you best at any time. Of course you can also duct heat into other rooms while the stove performs its magical beauty.

FR Performances et polyvalence

Capacité de chauffage considérable pour cette gamme de poêles à bois au design recherché, entièrement revêtus de faïence avec des éléments de grandes dimensions. Il est possible de choisir comment se chauffer : convection naturelle avec le système Multifuoco® ainsi que le contrôle électronique de la flamme BCS ; avec un système d'accumulation HSS qui chauffe encore plusieurs heures après l'extinction de la flamme. Il sera donc possible de choisir le mode de chauffage préféré à tout moment. La chaleur pourra aussi être canalisée et distribuée dans d'autres pièces.

DE Leistung und Vielseitigkeit

Diese Holzofen-Produktreihe mit ausgesuchtem Design und Komplettverkleidung mit einer großformatigen Majolika-Kachel verfügt über eine bemerkenswert hohe Heizleistung, bei der die Heizart ausgewählt werden kann: mit natürlicher Konvektion; mit Multifuoco® System, auch mit elektronischer Flammensteuerung per BCS-Fernsteuerung; mit HSS-Speichersystem, das noch Stunden nach Erlöschen der Flamme Wärme abgibt. Der gewünschte Heizmodus kann jederzeit beliebig eingestellt werden. Über ein Kanalsystem kann die Wärme auch auf andere Räume verteilt werden.

ES Desempeño y versatilidad

Notable capacidad de calefacción para esta gama de estufas de leña con un esmerado diseño totalmente revestidas de mayólica con elementos de grandes dimensiones. Opciones de calefacción: por convección natural, con Multifuoco® System, también con el control electrónico de la llama mediante mando a distancia BCS; con sistema de acumulación HSS que calienta durante muchas horas tras la extinción de la llama. Se puede configurar la modalidad de calefacción que se prefiere en cualquier momento. También se puede canalizar el calor a otros ambientes.



Compatte ed efficienti



Per riscaldare confortevolmente a convezione naturale o con Multifuoco®, anche con il beneficio di un performante sistema di accumulo che può essere installato anche successivamente.

EN Compact and efficient

For comfortable heating via natural convection or with Multifuoco®, also with the benefit of a high-performance heat storage system that can also be installed at a later date.

FR Compacts et efficaces

Pour réchauffer confortablement par convection naturelle ou par Multifuoco®, même avec le bénéfice d'un système d'accumulation performant qui peut être installé plus tard.

DE Kompakt und leistungsstark

Für angenehmes Heizen mit natürlicher Konvektion oder Multifuoco®, auch mit dem Vorzug eines leistungsstarken Wärmespeichersystems, das auch später installiert werden kann.

ES Compactas y eficientes

Para calentar por convección natural o con Multifuoco® de forma cómoda, incluso con el beneficio de un eficiente sistema de acumulación que puede instalarse en un futuro.



BCS Gestione elettronica



Massimo comfort di impiego grazie alla regolazione automatica della fiamma a legna, gestita con controllo elettronico da telecomando. Combustione perfetta, elevati rendimenti.

EN BCS electronic control

Maximum comfort thanks to automatic wood flame regulation, electronically controlled via remote control. Perfect combustion, high efficiency.

FR BCS Gestion électronique

Confort d'utilisation grâce au réglage automatique de la flamme, géré avec contrôle électronique par télécommande. Une combustion parfaite, hauts rendements.

DE BCS Elektronische Steuerung

Maximale Bedienerfreundlichkeit dank der automatischen Flammenregelung, die über eine elektronische Fernbedienung gesteuert wird. Perfekte Verbrennung, hohe Leistungswerte.

ES Gestión electrónica BCS

Máximo confort gracias a la regulación automática de la llama con un control electrónico mediante mando a distancia. Combustión perfecta, alto rendimiento.

Multifuoco® System



Uniformità di riscaldamento in tutto l'ambiente, dal pavimento al soffitto, senza sprechi. Percepisci sempre un calore confortevole in tutto il corpo, mai più piedi freddi.

EN Multifuoco® System

Uniform heating throughout your living areas, from the floor to the ceiling. Your body will always feel warm and comfortable; no more cold feet.

FR Multifuoco® System

Uniformité de chauffage du sol au plafond, sans gaspillages. Une chaleur confortable est perçue dans tout le corps, vous n'aurez plus jamais les pieds froids.



HSS Heat Storage System



Il piacere del calore si prolunga per ore anche dopo lo spegnimento del fuoco. Un modo naturale e salutare per incrementare il benefico riscaldamento per irraggiamento.

EN HSS Heat Storage System

The pleasure of the warmth is prolonged for hours after the flames go out. A natural and healthy way to increase the beneficial effect of radiated warmth.

DE HSS Heat Storage System

Die angenehme Wärme hält nach dem Erlöschen des Feuers noch einige Stunden an. Eine natürliche und gesunde Art, die Vorzüge einer Heizung durch Wärmeabstrahlung zu erhöhen.

FR HSS Heat Storage System

Le plaisir de la chaleur se prolonge des heures après l'extinction du feu. Une façon naturelle et salubre pour augmenter le bénéfice d'un chauffage par rayonnement.

ES HSS Heat Storage System

El placer del calor se prolonga durante horas incluso después de apagar el fuego. Una manera natural y saludable para aumentar los beneficios de la calefacción por radiación.



DE Multifuoco® System

Gleichmäßige Heizung des ganzen Raums vom Fußboden bis zur Decke. Somit immer eine angenehme Wärme am ganzen Körper und keine kalten Füße.

ES Multifuoco® System

Uniformidad de calefacción en todo el ambiente, del suelo al techo, sin desperdicios. Percibe siempre un calor confortable en todo el cuerpo. Nunca más pies fríos.



E929 D

Stufa a legna essenziale ed elegante nel suo design, rappresenta un equilibrio di stile, di raffinata e sobria piacevolezza. Rivestimento in Maiolica. Vetro curvo a filo porta. Anche in versione con sistema BCS. Bocchetta frontale uscita aria calda orientabile.

EN A minimalist and elegant wood-burning stove with a balanced style and sober, refined lines. Dressed with Majolica. Flush curved glass door. Also available in a version with BCS. Directionable front hot air vent.

DE Mit seinem minimalistischen Design verkörpert dieser Holzofen Stil und schlichte Eleganz. Majolika-Verkleidung. Bündig gebogene Glastür. Auch mit BCS-System erhältlich. Vorderseitige, ausrichtbare Luftaustrittsöffnung.

FR Poêle à bois au design essentiel et élégant, caractérisé par un équilibre de style, raffinement et beauté sobre. Habillage en faïence. Vitre incurvée affleurante. Disponible également en version avec système BCS. Grille de sortie d'air chaud frontale orientable.

ES Estufa de leña esencial y elegante en su diseño, que representa un equilibrio de estilo y agrado sobrio y refinado. Revestimiento de mayólica. Vidrio curvado a ras de la puerta. También en versión con sistema BCS. Boquilla frontal ajustable de salida del aire caliente.

COLORI - COLOURS

Bianco, Ardesia, Grigio Cerato, Nero Opaco, Rosso Lava, Giallo Acceso

cm 55 x 55 x 115

→ Specifications and colours P.164

7,9 kW
up to 230 m³





E929 D-H

Design dal carattere deciso, esprime la ricercatezza nella lavorazione della Maiolica con grandi superfici radianti. Vetro curvo a filo porta per una ampia visione della fiamma. Bocchetta frontale uscita aria calda orientabile. Disponibile anche in versione con sistema BCS.

EN This bold design expressed the refined surfaces of the Majolica, with large radiating surfaces. The flush curved glass door offers a clear view of the flame. Directional front hot air vent. Also available in a version with BCS.

DE Modell mit Charakter, bei dem die edle Bearbeitung der großen, glatten Wärmeabstrahlplatten aus Majolika gut zur Geltung kommt. Bündig gebogene Glastür mit Panoramansicht auf das Feuer. Vorderseitige, ausrichtbare Luftaustrittsöffnung. Auch mit BCS-System erhältlich.

FR Le design au caractère affirmé exprime tout le raffinement de la faïence aux grandes surfaces rayonnantes. Vitre incurvée affleurante pour une grande vision de la flamme. Grille de sortie d'air chaud frontale orientable. Disponible également en version avec système BCS.

ES Diseño de carácter resuelto, revela el esmero en la realización de la mayólica con grandes superficies radiantes. Vidrio curvado a ras de la puerta para amplia visibilidad de la llama. Boquilla frontal ajustable de salida del aire caliente. Disponible además con sistema BCS.

COLORI - COLOURS

Bianco, Ardesia, Grigio Cerato, Nero Opaco, Rosso Lava, Giallo Acceso

cm 55 x 55 x 170

→ Specifications and colours P.164 - 165



7,9 kW
up to 230 m³



E929 M

Stufa a legna moderna e raffinata, esprime con il suo equilibrio la capacità di essere una valida soluzione di arredo per ambienti di stile. Rivestimento in Maiolica. Vetro curvo a filo porta. Bocchetta frontale uscita aria calda orientabile. Anche in versione con sistema BCS.

EN A modern and refined wood-burning stove, with balanced forms able to blend in with stylish interiors. Dressed with Majolica. Flush curved glass door. Also available in a version with BCS. Directional front hot air vent.

DE Der moderne und elegante Ofen fügt sich mit seinem ausgewogenen Design auch in die stilvollsten Wohnräume ein. Majolika-Verkleidung. Bündig gebogene Glastür für maximale Sicht auf das Feuer. Vorderseitige, ausrichtbare Luftaustrittsöffnung. Auch mit BCS-System erhältlich.

FR Avec sa forme équilibrée, ce poêle à bois moderne et raffiné trouvera sa place dans différents styles de décoration. Habillage en faïence. Vitre incurvée affleurante. Grille de sortie d'air chaud frontale orientable. Aussi disponible en version avec système BCS.

ES Estufa de leña moderna y refinada, su equilibrio revela una capacidad de decoración adecuada para ambientes de estilo. Revestimiento de mayólica. Vidrio curvado a ras de la puerta. Boquilla frontal ajustable de salida del aire caliente. También en versión con sistema BCS.

COLORI - COLOURS

Bianco, Ardesia, Grigio Cerato, Nero Opaco, Rosso Lava, Giallo Acceso

cm 55 x 55 x 115

→ Specifications and colours P.165



7,9 kW
up to 230 m³



E929 M-H

Moderna dal carattere deciso, questa stufa a legna esprime la ricercatezza nella lavorazione a mano della Maiolica, con grandi superfici lisce radianti. Bocchetta frontale uscita aria calda orientabile. Anche in versione con sistema di controllo elettronico della fiamma BCS.

EN With its bold modern design, this wood-burning stove has refined hand-finished surfaces in Majolica, with large radiating surfaces. Directional front hot air vent. Also available in a version with BCS electronic flame control system.

DE Ein Modell mit Charakter, bei dem die edle Bearbeitung der großen, glatten Wärmeabstrahlplatten aus Majolika gut zur Geltung kommt. Vorderseitige, ausrichtbare Luftaustrittsöffnung. Auch als Version mit elektronischer BCS Flammensteuerung erhältlich.

FR Ce poêle à bois moderne au caractère affirmé exprime le raffinement de la faïence réalisée à la main, avec de grandes surfaces rayonnantes lisses. Grille de sortie d'air chaud frontale orientable. Également disponible en version avec contrôle électronique de la flamme BCS.

ES Esta estufa de leña moderna y de carácter resuelto expresa el esmero en la hechura a mano de la mayólica, con grandes superficies lisas radiantes. Boquilla frontal ajustable de salida del aire caliente. También en versión con sistema de control electrónico de la llama BCS.

COLORI - COLOURS

Bianco, Ardesia, Grigio Cerato, Nero Opaco, Rosso Lava, Giallo Acceso

cm 55 x 55 x 170

→ Specifications and colours P.166



7,9 kW
up to 230 m³



E929 T

Raffinata nella forma si apre nella sua parte più alta nell'originale estetica a tulipano che la rende unica. Interamente rivestita in Maiolica lavorata a mano. Vetro curvo a filo porta. Bocchetta frontale uscita aria calda orientabile. Anche in versione con sistema BCS.

EN This unique stove has a refined shape and an original tulip design with top opening. Fully dressed with Majolica. Flush curved glass door. Directional front hot air vent. Also available in a version with BCS.

DE Der raffinierte Ofen besitzt eine originelle Tulpenform, welche sich im oberen Bereich öffnet. Vollständig mit von Hand gefertigter Majolika verkleidet. Bündig gebogene Glastür. Vorderseitige, ausrichtbare Luftaustrittsöffnung. Auch mit BCS-System erhältlich.

FR Poêle raffiné à la ligne évasée dans le haut, créant un original effet en tulipe qui le rend unique. Entièrement revêtu de faïence réalisée à la main. Vitre incurvée affleurante. Grille de sortie d'air frontale orientable. Également disponible en version BCS.

ES Su formada refinada y su apertura superior en el original aspecto de tulipán hacen de ella un artículo único. Totalmente revestida de mayólica elaborada a mano. Vidrio curvado a ras de la puerta. Boquilla frontal ajustable de salida del aire caliente. También con sistema BCS.

COLORI - COLOURS

Bianco, Ardesia, Grigio Cerato, Nero Opaco, Rosso Lava, Giallo Acceso

cm 58 x 58 x 153

→ Specifications and colours P.166 - 167



7,9 kW
up to 230 m³



ROUND

Stufa a legna originale nella sua composizione anche bicolore, con l'alternanza di superfici lisce e decorate con motivi geometrici. Rivestimento in Maiolica. Vetro curvo a filo porta. Bocchetta frontale orientabile. Anche con BCS.

EN An original wood-burning stove with a two-tone composition with alternating smooth and geometric decorated areas. Dressed with Majolica. Flush curved glass door. Directional front hot air vent. Also with BCS.

DE Origineller Holzofen, auch in zweifarbiger Ausführung, mit wechselndem Muster aus glatten und geometrischen Oberflächen. Majolika-Verkleidung. Bündig gebogene Glastür. Ausrichtbare Luftaustrittsöffnung. Auch mit BCS-System.

FR Poêle original caractérisé par une alternance de surfaces lisses et décorées de motifs géométriques, existant aussi en version bicolore. Habillage en faïence. Vitre incurvée affleurante. Grille frontale orientable. Disponible avec BCS.

ES Estufa de leña original en composición incluso bicolor, con el alternarse de superficies lisas y decoradas con motivos geométricos. Revestimiento de mayólica. Vidrio curvado a ras de la puerta. Boquilla frontal ajustable. También con BCS.

COLORI - COLOURS

Bianco, Ardesia, Grigio Cerato, Rosso Lava. Bicolore - two-colour versions: **Bianco Grigio/Terra Cotta, Bianco/Ardesia**

cm 54 x 54 x 120

→ Specifications and colours P.167



7,9 kW
up to 230 m³



ROUND-M

Caratterizzata nella sua composizione dall'alternanza di superfici lisce e decorate, si distingue per un design dal carattere audace. Rivestimento in Maiolica. Vetro curvo a filo porta. Bocchetta frontale orientabile. Anche con BCS.

EN Characterised by its composition with alternating smooth and decorated areas, this stove has an audacious character. Dressed with Majolica. Flush curved glass door. Directional front hot air vent. Also with BCS.

DE Dieser Ofen mit abwechselnd glatten und dekorierten Oberflächen zeichnet sich durch seinen gewagten Stil aus. Majolika-Verkleidung. Bündig gebogene Glasür. Ausrichtbare Luftaustrittsöffnung. Auch mit BCS-System.

FR Caractérisé par une alternance de surfaces lisses et décorées, ce poêle se distingue par un design audacieux. Habillage en faïence. Vitre incurvée affleurante. Grille frontale orientable. Également disponible avec système BCS.

ES Su composición se caracteriza por el alternarse de superficies lisas y decoradas, y se destaca por el diseño de carácter audaz. Revestimiento de mayólica. Vidrio curvado a ras de la puerta. Boquilla frontal ajustable. También con BCS.

COLORI - COLOURS

Bianco, Ardesia, Grigio Cerato, Rosso Lava. Bicolore - two-colour versions: **Bianco Grigio/Terra Cotta, Bianco/Ardesia**

cm 54 x 54 x 136

→ Specifications and colours P.168 - 169



7,9 kW
up to 230 m³



ROUND-H

Stufa a legna con ampie superfici in Maiolica lavorate a contrasto, decorate e lisce. Ampio spazio per il sistema di accumulo. Vetro curvo a filo porta. Bocchetta frontale orientabile. Anche in versione con BCS.

EN A wood-burning stove with large contrasting surfaces in Majolica with smooth and decorated areas. Lots of room for the HSS. Flush curved glass door. Directional front hot air vent. Also available with BCS.

DE Holzofen mit großen Majolika-Platten mit kontrastdekorierten und glatten Oberflächen. Großes Wärmespeichersystem. Bündig gebogene Glastür. Ausrichtbare Luftaustrittsöffnung. Auch mit BCS-System.

FR Poêle à bois revêtu de grandes surface en faïence contrastées, décorées et lisses. Grand espace pour le système d'accumulation. Vitre incurvée affleurante. Grille frontale orientable. Aussi disponible en version avec BCS.

ES Estufa de leña con amplias superficies de mayólica elaboradas en contraste, decoradas y lisas. Amplio espacio para el sistema de acumulación. Vidrio curvado aras de la puerta. Boquilla frontal ajustable. También en versión con BCS.

COLORI - COLOURS

Bianco, Ardesia, Grigio Cerato, Rosso Lava. Bicolore - two-colour versions: **Bianco Grigio/Terra Cotta, Bianco/Ardesia**

cm 54 x 54 x 166

→ Specifications and colours P.168

7,9 kW
up to 230 m³





E929 C

Stufa a legna dove la classicità delle forme trova la sua massima espressione nella pregiata lavorazione della Maiolica. Vetro curvo a filo porta. Con o senza bocchetta frontale orientabile. Disponibile anche in versione con BCS. Possibilità di posare la stufa a terra o su piedini rivestiti in Maiolica.

EN A wood-burning stove with a classic shape and beautiful Majolica. Flush curved glass door. Available with or without directional front hot air vent. Also available with BCS. This stove can be placed directly on the floor or on feet dressed with Majolica.

DE Die klassische Form findet durch die hochwertige Majolikakeramik. Bündig gebogene Glastür. Vorderseitige mit oder ohne ausrichtbare Luftaustrittsöffnung. Auch mit BCS-System. Entfernbare Füße.

FR Poêle à bois où le classicisme des formes trouve toute son expression dans la faïence. Vitre incurvée affleurante. Avec ou sans grille frontale orientable. Disponible également avec BCS. Possibilité de poser le poêle au sol ou sur des pieds revêtus de faïence.

ES Estufa de leña con formas clásicas que hallan la máxima expresión en la preciosa elaboración de la mayólica. Vidrio curvado a ras de la puerta. Versión con o sin boquilla. Disponible también con BCS. Posibilidad de poner la estufa en el suelo o sobre pies revestidos de mayólica.

COLORI - COLOURS

Bianco, Bordeaux, Canapa. Con decorazioni - with decorations:
Bianco Antico/Blu Verdemare - Bianco Antico/Terra Bruna

cm 59 x 59 x 141

→ Specifications and colours P.161 - 162



7,9 kW
up to 230 m³



E929 C-H

Stufa a legna unica nel suo stile, forte nella sua presenza. Design classico con motivi in rilievo della Maiolica. Con o senza la bocchetta frontale orientabile. Vetro curvo a filo porta. Anche in versione con BCS.

EN A wood-burning stove with a unique style and strong presence. A classic design with relief patterns in the Majolica. Available with or without directional front hot air vent. Flush curved glass door. Also available with BCS.

DE Holzofen mit einzigartigem, starkem Stil. Klassische Form mit Reliefmotiven der Majolika. Bündig gebogene Glastür. Vorderseitige mit oder ohne ausrichtbare Luftaustrittsöffnung. Auch mit BCS-System.

FR Poêle à bois au style unique et à la présence forte. Design classique grâce aux motifs en relief de la faïence. Vitre incurvée affleurante. Avec ou sans grille frontale orientable. Aussi disponible avec BCS.

ES Estufa de leña con estilo único y fuerte presencia. Diseño clásico con motivos de relieve de la mayólica. Vidrio curvado a ras de la puerta. Versión con o sin boquilla frontal de salida ajustable. También en versión con BCS.

COLORI - COLOURS

Bianco, Bordeaux, Canapa. Con decorazioni - with decorations:
Bianco Antico/Blu Verdemare - Bianco Antico/Terra Bruna

cm 59 x 59 x 191

→ Specifications and colours P.162 - 163



7,9 kW
up to 230 m³



E928 R

NEW

Sapere classico per questo modello con rivestimento realizzato in grandi pannelli in Maiolica con preziosi decori. Le grandi superfici di Maiolica ne esaltano la capacità radiante e prolungano la diffusione del calore.

EN A classic feel for this model clad with large Majolica panels featuring precious decorations. The large Majolica surfaces enhance the radiant capacity and prolong the heat diffusion.

DE Modell im klassischen Stil mit Verkleidung aus großen Majolika-Platten mit wunderschönen Dekorationen. Die großen Oberflächen der Majolika erhöhen seine Strahlungskapazität und verlängern die Wärmeverteilung.

FR Une touche classique pour ce modèle caractérisé par un revêtement fait de grands panneaux de faïence rehaussés de décorations précieuses. Les grandes surfaces en faïence renforcent la capacité de rayonnement et prolongent la diffusion de la chaleur.

ES Sabor clásico para este modelo con revestimiento de grandes paneles de mayólica con preciadas decoraciones. Las grandes superficies de la mayólica potencian su capacidad radiante y prolongan la difusión del calor.

COLORI - COLOURS

Bianco, Bianco Grigio, Canapa, Nero Opaco, Rosso Lava, Verde Mirto

cm 65 x 49 x 117

→ Specifications and colours P.160



11,0 kW
up to 315 m³





11,0 kW
up to 315 m³

E928 Bianco

E928 Steel

NEW

Moderna nel design e nei materiali: rivestimento in metallo e piano in acciaio. Il frontale nero e l'ampio vetro esaltano la piacevole visione della fiamma.

EN A modern design and materials: metal cladding and a steel surface. The black front and large glass panel enhance the pleasant view of the flame.

DE Modern in Design und Materialien: Metallverkleidung und Stahlplatte. Die schwarze Front und das großzügige Glas verstärken den angenehmen Blick auf die Flamme.

FR Design et matériaux modernes: revêtement métallique et plateau en acier. La façade noire et la grande porte vitrée offrent une vue agréable sur le feu.

ES Moderno en diseño y materiales: revestimiento metálico y superficie de acero. El frontal negro y el amplio cristal realzan la agradable visión de la llama.

COLORI - COLOURS

Bianco, Corten, Nero

cm 60 x 47 x 114

→ Specifications and colours P.154



E928 Steel Nero Opaco





E928 C

Stufa a legna che nell'equilibrio della forma e nella morbidezza delle linee rivisita, attualizzandolo, lo stile classico delle stufe in Maiolica. Interamente rivestita con pannelli in Maiolica di grande formato. Frontale con o senza bocchetta orientabile. Anche in versione ermetica, e con BCS.

EN A wood-burning stove with soft lines and a balanced form, recreating a classic stove design in Majolica. Completely covered in large format Majolica panels. Available with or without directional front hot air vent. Also available as an airtight version, and with BCS.

DE Holzofen mit weichen Formen und weicher Silhouette im klassischen Stil der Majolikaöfen. Verkleidung mit großen Majolika-Kacheln erhältlich. Vorderseitige mit oder ohne ausrichtbare Luftaustrittsöffnung. Auch als raumluftunabhängige Version und mit BCS-System.

FR Avec l'équilibre de sa forme et la douceur de ses lignes, ce poêle à bois remet au goût du jour le style classique des poêles en faïence. Il est entièrement revêtu de panneaux de faïence de grande taille. Avec ou sans grille frontale orientable. Disponible en version étanche et avec BCS.

ES Estufa de leña que reinterpreta y actualiza el estilo clásico de las estufas de mayólica en cuanto a equilibrio de la forma y suavidad de las líneas. Totalmente revestida de paneles de mayólica grandes. Versión con o sin boquilla frontal ajustable. También en versión hermética y con BCS.

COLORI - COLOURS

Bianco, Bianco Grigio, Rosso Lava, Kaki, Verde Mirto, Canapa

cm 65 x 48 x 144

→ Specifications and colours P.155 - 156







E928 C-M

Stufa a legna che spicca per la sua originalità negli equilibri della forma, per la piacevolezza del rivestimento in Maiolica, che la rende di grande impatto, tale da caratterizzare con stile un ambiente. Con o senza bocchetta frontale orientabile. Anche in versione ermetica, e con BCS.

EN A wood-burning stove with an original design and balanced forms. The beautiful Majolica cladding gives it a strong look that can set off any interior. Available with or without directional front hot air vent. Also available as an airtight version, and with BCS.

DE Holzofen, dessen harmonische Formgebung und die ästhetische Majolika-Verkleidung mit großer Wirkung jedes Ambiente stilvoll für sich einnimmt. Vorderseite, mit oder ohne ausrichtbare Luftaustrittsöffnung. Auch als raumluftunabhängige Version und mit BCS-System.

FR Poêle à bois caractérisé par sa forme en équilibre et son beau habillage en faïence. Avec son fort impact visuel, il distinguera avec style la décoration de la pièce où il sera installé. Avec ou sans grille frontale orientable. Disponible en version étanche et avec BCS.

ES Estufa de leña que sobresale por la originalidad en los equilibrios de la forma, por la belleza del revestimiento de mayólica, que la torna imponente, apta para dar un toque de estilo a un ambiente. Versión con o sin boquilla frontal ajustable. También en versión hermética y con BCS.

COLORI - COLOURS

Bianco, Bianco Grigio, Rosso Lava, Kaki, Verde Mirto, Canapa

cm 65 x 48 x 176

→ Specifications and colours P.157 - 158



11,0 kW
up to 315 m³





E928 C-H

Stufa a legna che sa caratterizzare un ambiente con gusto, stile e armonia. Rivestimento in Maiolica lavorata con cura artigianale; con o senza bocchetta frontale orientabile. Anche in versione ermetica e con BCS. Notevole capacità di accumulo del sistema HSS.

EN A wood-burning stove that will add character to a room with style and harmony. The hand-finished Majolica cladding makes it unique. Available with or without directional front hot air vent. Also available as an airtight version, and with BCS. Significant HSS capacity.

DE Holzofen für einen geschmackvollen, harmonischen Raum. Einzigartige, handwerklich sorgfältig hergestellte Majolika-Verkleidung mit oder ohne ausrichtbare Luftaustrittsöffnung. Auch als hermetische Version und mit BCS-System. Hohe HSS-Speicherkapazität.

FR Un poêle à bois capable de distinguer une pièce avec goût, style et harmonie. Le habillage en faïence artisanal fait de lui un modèle unique. Avec ou sans grille frontale orientable. Aussi disponible en version étanche et BCS. Grande capacité d'accumulation du système HSS.

ES Estufa de leña para dar a los ambientes un toque de gusto, estilo y armonía. Única gracias al revestimiento de mayólica elaborada con esmero artesanal. Versión con o sin boquilla frontal ajustable. También en versión hermética y con BCS. Alta capacidad de acumulación del sistema HSS.

COLORI - COLOURS

Bianco, Bianco Grigio, Rosso Lava, Kaki, Verde Mirto, Canapa

cm 65 x 48 x 209

→ Specifications and colours P.156 - 157





E928

Stufa dal design lineare completamente rivestita in Maiolica, riscalda l'ambiente per convezione naturale e irraggiamento. Bocchetta frontale uscita aria calda orientabile. Disponibile anche in versione ermetica, con prelievo dell'aria comburente dall'esterno, e con sistema BCS.

EN A stove with a linear design completely dressed with Majolica. It provides heat via natural convection and radiation. Directional front hot air vent. Also available as an airtight version, with external combustion air intake, and with BCS.

DE Holzofen mit linearem Design und kompletter Majolikaverkleidung. Erwärmt den Raum per natürlicher Konvektion und Wärmeabstrahlung. Ausrichtbare Luftaustrittsöffnung. Auch als raumluftunabhängige Version erhältlich, mit Verbrennungsluft-Zufuhr von außen und mit BCS-System.

FR Ce poêle au design linéaire entièrement revêtu de faïence chauffe la pièce par convection naturelle et rayonnement. Grille de sortie d'air chaud frontale orientable. Disponible également en version étanche, avec prélèvement de l'air comburant à l'extérieur et avec système BCS.

ES Estufa con diseño lineal totalmente revestida de mayólica, que calienta el ambiente por convección natural e irradiación. Boquilla frontal ajustable de salida del aire caliente. Disponible también en versión hermética, con toma del aire comburente del exterior y con sistema BCS.

COLORI - COLOURS

Bianco, Nero Opaco, Rosso Lava, Terra Cotta

cm 57 x 45 x 127

→ Specifications and colours P.153



11,0 kW
up to 315 m³



E928 M

Stufa a legna dal design lineare, slanciata nelle proporzioni, rivestita in Maiolica. Bocchetta frontale uscita aria calda orientabile. Disponibile anche in versione ermetica, con prelievo dell'aria comburente dall'esterno, e con sistema di controllo elettronico della fiamma BCS.

EN A stove with a linear design and slim proportions, completely dressed with Majolica. Directional front hot air vent. Also available as an airtight version, with external combustion air intake, and with BCS electronic flame control system.

DE Holzofen mit linearem Design, schlanken Proportionen und Majolika-Verkleidung. Vorderseitige, ausrichtbare Luftaustrittsöffnung. Auch als raumluftunabhängige Version erhältlich, mit Verbrennungsluft-Zuführung von außen und mit elektronischer Flammensteuerung (BCS).

FR Poêle à bois au design linéaire et aux proportions élancées, avec habillage en faïence. Grille de sortie d'air chaud frontale orientable. Disponible également en version étanche, avec prélèvement de l'air comburant à l'extérieur et avec système de contrôle électronique de la flamme BCS.

ES Estufa de leña con diseño lineal, esbelta en sus proporciones, revestida de mayólica. Boquilla frontal ajustable de salida del aire caliente. Disponible también en versión hermética, con toma del aire comburente del exterior y con sistema de control electrónico de la llama BCS.

COLORI - COLOURS

Bianco, Nero Opaco, Rosso Lava, Terra Cotta

cm 57 x 45 x 141

→ Specifications and colours P.159 - 160



11,0 kW
up to 315 m³





E928 H

Stufa a legna di grande impatto, completamente rivestita in Maiolica lavorata a mano con pannelli di grandi dimensioni. Bocchetta frontale uscita aria calda orientabile. Disponibile anche in versione ermetica, con prelievo dell'aria comburente dall'esterno, e con sistema BCS.

EN A stove with a bold design completely covered with large hand-finished Majolica panels. Directional front hot air vent. Also available as an airtight version, with external combustion air intake, and with BCS.

DE Holzofen mit großer Wirkung und handgearbeiteter Majolika-Verkleidung mit großformatigen Kacheln. Ausrichtbare Luftaustrittsöffnung. Auch als raumluftunabhängige Version erhältlich, mit Verbrennungsluft-Zuführung von außen und mit BCS-System.

FR Poêle à bois à fort impact, entièrement revêtu de faïence façonnée à la main avec des panneaux de grandes dimensions. Grille de sortie d'air chaud frontale orientable. Disponible également en version étanche, avec prélèvement de l'air comburant à l'extérieur et avec système BCS.

ES Estufa de leña de gran impacto, totalmente revestida de mayólica elaborada a mano con paneles grandes. Boquilla frontal ajustable de salida del aire caliente. Disponible también en versión hermética, con toma del aire comburente del exterior y con sistema BCS.

COLORI - COLOURS

Bianco, Nero Opaco, Rosso Lava, Terra Cotta

cm 57 x 45 x 187

→ Specifications and colours P.159



11,0 kW
up to 315 m³



E928 A

Stufa dall'innovativo design con focolare rialzato, per apprezzare maggiormente la bellezza del fuoco. Rivestimento in Maiolica. Bocchetta frontale uscita aria calda orientabile. Disponibile anche in versione ermetica, con prelievo dell'aria comburente dall'esterno, e con sistema BCS.

EN A stove with an innovative design with a raised firebox for greater appreciation of the flame. Dressed with Majolica. Directional front hot air vent. Also available as an airtight version, with external combustion air intake, and with BCS.

DE Holzofen mit innovativem Design mit erhöhter Feuerschale, um die Schönheit des Feuers zu betonen. Majolika-Verkleidung. Ausrichtbare Luftaustrittsöffnung. Auch als raumluftunabhängige Version erhältlich, mit Verbrennungsluft-Zufuhr von außen und mit BCS-System.

FR Poêle au design innovant avec foyer rehaussé, pour apprécier encore plus la beauté du feu. Habillage en faïence. Grille de sortie d'air chaud frontale orientable. Disponible également en version étanche, avec prélèvement de l'air comburant à l'extérieur et avec système BCS.

ES Estufa con diseño innovador con hogar elevado, para apreciar mejor la belleza del fuego. Revestimiento de mayólica. Boquilla frontal ajustable de salida del aire caliente. Disponible también en versión hermética, con toma del aire comburente del exterior y con sistema BCS.

COLORI - COLOURS

Bianco, Nero Opaco, Rosso Lava, Terra Cotta

cm 57 x 45 x 141

→ Specifications and colours P.154



11,0 kW
up to 315 m³





E928 S

Stufa a legna dal particolare design, con pratico scaldavivande posto nella parte superiore. Interamente rivestita in Maiolica. Bocchetta frontale uscita aria calda orientabile. Disponibile anche in versione ermetica, con prelievo dell'aria comburente dall'esterno, e con sistema BCS.

EN A stove with an unusual design, with a practical oven in the upper part. Completely covered in Majolica. Directional front hot air vent. Also available as an airtight version, with external combustion air intake, and with BCS.

DE Holzofen mit besonderem Design und praktischem Speisewärmer an der Oberseite. Komplette Majolika-Verkleidung. Ausrichtbare Luftaustrittsöffnung. Auch als raumluftunabhängige Version erhältlich, mit Verbrennungsluft-Zuführung von außen und mit BCS-System.

FR Poêle à bois au design particulier avec chauffe-plat très pratique dans la partie supérieure. Entièrement revêtu de faïence. Grille de sortie d'air chaud frontale orientable. Disponible également en version étanche, avec prélèvement de l'air comburant à l'extérieur et avec système BCS.

ES Estufa de leña con diseño particular, con práctico calentaplatos situado en la parte superior. Totalmente revestida de mayólica. Boquilla frontal ajustable de salida del aire caliente. Disponible también en versión hermética, con toma del aire comburente del exterior y con sistema BCS.

COLORI - COLOURS

Bianco, Nero Opaco, Rosso Lava, Terra Cotta

cm 57 x 45 x 141

→ Specifications and colours P.160 - 161



Stile esclusivo

Ampia e diversificata, la proposta di questa famiglia offre soluzioni originali che si contraddistinguono per originalità. Focolari performanti, disponibili in differenti potenze, idonei per riscaldare ambienti di piccole, medie e grandi dimensioni, sono rivestiti con elementi in Maiolica di grandi formati, o in acciaio. Possono riscaldare a convezione naturale o a ventilazione forzata grazie al sistema Multifuoco® System che consente anche la canalizzazione in altri ambienti. Soluzioni di riscaldamento funzionali che si fanno apprezzare per la loro originalità.

EN Original design

With a broad and diverse selection, this range of products offers highly original solutions. High-performance fireboxes, available in different capacities, ideal for heating small, medium-sized and large spaces. Completely shielded in large Majolica panels or steel. They can provide heat either via natural convection or forced ventilation thanks to the Multifuoco® System, which also allows the heat to be ducted into other rooms. Functional heating solutions with a highly original design. Available in different colors for statements to be made.

FR Exklusivité originale

Étendue et diversifiée, cette famille propose des solutions qui se distinguent par leur originalité. Foyers performants, disponibles en différentes puissances, adaptés pour chauffer de petits, moyens et grands espaces, ils sont revêtus d'éléments en faïence de grande taille ou acier. Ils peuvent chauffer par convection naturelle ou par ventilation forcée grâce au système Multifuoco® qui permet également la canalisation dans d'autres pièces. Des solutions de chauffage fonctionnelles qui seront appréciées pour leur originalité.

DE Originelle Exklusivität

Das Sortiment dieser weitgefächerten und vielseitigen Produktfamilie bietet originelle Lösungen, die sich durch Originalität abheben. Hochleistungsfähige Feuerstätten mit verschiedenen Leistungsstärken, mit denen kleine, mittlere und große Räume beheizt werden können, und die mit großformatigen Majolika-Kacheln oder Stahl verkleidet sind. Sie heizen per natürlicher Konvektion oder Gebläselüftung dank des Multifuoco® Systems, das auch die Kanalisierung in andere Räume ermöglicht. Funktionelle Heizlösungen, die durch Originalität bestechen.

ES Exclusividad original

La propuesta amplia y diversificada de esta gama ofrece soluciones originales que se destacan por su originalidad. Hogares de alto desempeño, disponibles con distintas potencias, ideales para calentar ambientes pequeños, medianos y grandes, revestidos con elementos de mayólica en formato grande o de acero. Pueden calentar por convección natural o ventilación forzada gracias al sistema Multifuoco® System que posibilita además la canalización a otros ambientes. Soluciones de calefacción funcionales que saben cautivar por su originalidad.

Piacevole Design



Stufe di design che rappresentano nuove proposte stilistiche. L'originalità delle forme e dei colori tipicamente vintage, la versatilità di un focolare che si trasforma in tante soluzioni.

EN Attractive design

Designer stoves that offer new styles. Original forms and vintage colours, the versatility of a firebox that transforms into many different solutions.

FR Design agréable

Poêles design offrant de nouvelles propositions de style. Originalité des formes et couleurs vintage, polyvalence d'un foyer qui propose de nombreuses solutions.

DE Angenehmes Design

Design-Öfen mit neuen stilistischen Ansätzen. Die Originalität der Vintage-Formen und -Farben, die Vielseitigkeit eines in zahlreiche Lösungen umwandelbaren Heizeinsatzes.

ES Diseño agradable

Estufas de diseño que ofrecen novedosas propuestas de estilo. Formas originales y colores típicamente vintage, un hogar versátil que se adapta a muchas soluciones.





Multifuoco® System



Uniformità di riscaldamento in tutto l'ambiente, dal pavimento al soffitto, senza sprechi. Percepisci sempre un calore confortevole in tutto il corpo, mai più piedi freddi.

EN Multifuoco® System

Uniform heating throughout your living areas, from the floor to the ceiling. Your body will always feel warm and comfortable; no more cold feet.

FR Multifuoco® System

Uniformité de chauffage du sol au plafond, sans gaspillages. Une chaleur confortable est perçue dans tout le corps, vous n'aurez plus jamais les pieds froids.

DE Multifuoco® System

Gleichmäßige Heizung des ganzen Raums vom Fußboden bis zur Decke. Somit immer eine angenehme Wärme am ganzen Körper und keine kalten Füße.

ES Multifuoco® System

Uniformidad de calefacción en todo el ambiente, del suelo al techo, sin desperdicios. Percibe siempre un calor confortable en todo el cuerpo. Nunca más pies fríos.



Maiolica



L'esclusiva lavorazione artigianale di pezzi unici in Maiolica, che si plasmano a mano, e con sapiente maestria, caratterizzano e distinguono le stufe e tutti i prodotti Piazzetta.

EN Majolica

The exclusive and unique hand-crafted Majolica, which is formed by hand by expert craftsmen, characterises and distinguishes Piazzetta stoves and products.

FR Faïence

Les pièces uniques en faïence, modelées à la main avec une maîtrise artisanale soignée et exclusive, distinguent les poêles et tous les produits Piazzetta.

DE Majolika

Die Öfen und die anderen Produkte von Piazzetta zeichnen sich durch die exklusive Verarbeitung der Einzelstücke aus Majolika, die meisterhaft von Hand geformt werden, aus.

ES Mayólica

El exclusivo trabajo artesanal de las piezas únicas en mayólica, trabajadas a mano con maestría, caracterizan y distinguen las estufas y todos los productos Piazzetta.



BONNY

Il design dalle linee dolci e i colori morbidi regalano emozioni e fascino, richiamando alla memoria un piacevole sapore vintage. Il rivestimento in Maiolica è realizzato con elementi di grande formato, grazie alla maestria artigianale.

EN This design with its soft lines and colours has a decidedly vintage feel. The Majolica cladding is made from large panels and finished by hand.

DE Das Design mit seinen weichen Formen und sanften Farben verleiht dem Ofen seinen besonderen Vintage-Charme. Die Verkleidung besteht dank der Handwerkskunst aus Majolika mit großformatigen Kacheln.

FR Le design aux lignes douces et les couleurs tendres de ce poêle procurent émotions et charme et évoquent une agréable saveur vintage. L'habillage en faïence est réalisé avec des éléments de grande taille, grâce à la maîtrise artisanale de l'entreprise.

ES El diseño de líneas armoniosas y los colores suaves regalan emociones y encanto, evocando en la memoria un agradable sabor vintage. El revestimiento de mayólica está hecho con elementos de formato grande, gracias a la maestría artesana.

COLORI - COLOURS

Anice, Bianco, Cipria, Crema, Moka, Tè Verde

cm 81 x 46 x 109

→ Specifications and colours P.148



9,0 kW
up to 260 m³





9,0 kW
up to 260 m³

THELMA

Stufa a legna dallo spiccato carattere e dall'intensa forza espressiva di uno stile unico che richiama il passato. Racchiudono il focolare degli elementi di Maiolica di grande formato, realizzati con maestria artigiana. Massima visione del fuoco grazie al vetro di ampia superficie.

EN A wood-burning stove with a strong character and a unique vintage style. Large hand-finished Majolica panels surround the firebox. A clear view of the flame is provided by the large glass panel.

DE Holzofen mit ausgeprägtem Charakter und der intensiven Ausdrucksstärke eines einzigartigen, klassischen Stils. Großformatige, handgefertigte Majolika-Kacheln umschließen den Heizeinsatz. Die Panoramascheibe bietet eine maximale Sicht auf das Feuer.

FR Poêle à bois au caractère affirmé et à la force expressive d'un style unique qui rappelle le passé. Le foyer est entouré d'éléments en faïence de grande taille, réalisés avec une maîtrise artisanale. Vision maximale du feu grâce à la grande vitre.

ES Estufa de leña con carácter definido y fuerza expresiva intensa de un estilo único que evoca el pasado. Elementos de mayólica de formato grande, realizados con maestría artesana, hacen de marco para el hogar. Máxima visibilidad del fuego gracias al vidrio de superficie amplia.

COLORI - COLOURS

Anice, Bianco, Cipria, Crema, Moka, Tè Verde

cm 71 x 46 x 100

→ Specifications and colours P.171







QUBE 1

Design compatto e stile moderno, per inserirsi con gusto e leggerezza in ambienti di vario stile. Rivestimento in Maiolica finemente lavorata a mano. Le linee decise racchiudono l'innovativo focolare a legna. Possibilità di installazione con mensola.

EN With a compact design and modern styling, this stove can blend into all kinds of interiors. Dressed with hand-finished Majolica. Strong lines enclose the innovative wood-burning firebox. Also available with a shelf.

DE Mit seinem kompakten Design und modernen Stil fügt er sich geschmackvoll und mit Leichtigkeit in diverse Einrichtungsstile ein. Liebevoll handgefertigte Majolika-Verkleidung. Klare Linien umschließen den innovativen Heizeinsatz für Holzfeuerung. Regalmontage möglich.

FR Design compact et style moderne, pour s'intégrer avec goût et légèreté dans des pièces de style varié. Revêtement en faïence finement façonné à la main. Les lignes affirmées abritent un foyer à bois innovant. Possibilité d'installation avec une étagère.

ES Diseño compacto y estilo moderno, para adaptarse con gusto y ligereza a ambientes de estilo. Revestimiento de mayólica finamente elaborada a mano. Las líneas resueltas encierran el innovador hogar de leña. Posibilidad de instalación con repisa.

COLORI - COLOURS

Bianco Antico, Ardesia, Rosso Lava, Giallo Acceso, Sahara

cm 60 x 47 x 63

→ Specifications and colours P.169





QUBE 2

La compattezza e il lineare equilibrio dei volumi rendono questo modello di stufa a legna davvero unico. Rivestimento in Maiolica finemente lavorata a mano. Il suo stile impreziosisce ed esalta le sue forme essenziali e geometriche.

EN The compact design and linear balance of volumes make this wood-burning stove truly unique. Dressed with hand-finished Majolica. The style of this design brings out its minimalist and geometric shapes.

DE Die kompakte Größe und das lineare Gleichgewicht machen dieses Holzofenmodell einzigartig. Liebevoll handgefertigte Majolika-Verkleidung. Sein Stil veredelt und betont seine minimalistische, geometrische Form.

FR La forme compacte et l'équilibre linéaire des volumes font de ce modèle un poêle à bois vraiment unique. Revêtement en faïence finement façonné à la main. Son style enrichit et exalte ses formes essentielles et géométriques.

ES La compacidad y el equilibrio lineal de los volúmenes hacen de esta estufa de leña un modelo realmente único. Revestimiento de mayólica finamente elaborada a mano. Su estilo enriquece y exalta las formas esenciales y geométricas.

COLORI - COLOURS

Bianco Antico, Ardesia, Rosso Lava, Giallo Acceso, Sahara

cm 60 x 47 x 119

→ Specifications and colours P.170



9,0 kW
up to 260 m³



QUBE 3

Originale stufa a legna prevista per una installazione sospesa. Elegantemente rivestita con pannelli in Maiolica di grande formato. Le linee decise ed essenziali del rivestimento sono perfette per gli ambienti contemporanei.

EN This original wood-burning stove is designed for suspended installation. Elegantly covered with large-format Majolica panels. The bold and minimalist lines of the cladding are perfect for contemporary interiors.

DE Origineller Holzofen mit Auslegung als Hängeversion. Elegante großformatige Majolika-Verkleidung, deren klare und minimalistische Linien sich perfekt in ein modernes Wohnambiente einfügen lassen.

FR Poêle à bois original prévu pour une installation suspendue et élégamment revêtu de panneaux en faïence de grande taille. Les lignes affirmées et essentielles du revêtement sont parfaites pour les espaces contemporains.

ES Original estufa de leña para instalación suspendida. Elegantemente revestida con paneles de mayólica de formato grande. Las líneas resueltas y esenciales del revestimiento son perfectas para los ambientes modernos.

COLORI - COLOURS

Bianco Antico, Ardesia, Rosso Lava, Giallo Acceso, Sahara

cm 60 x 47 x 124

→ Specifications and colours P.170



9,0 kW
up to 260 m³



QUBE 4

Grande impatto scenografico per una originale stufa a legna interamente rivestita in Maiolica fatta a mano, con pannelli di grandi dimensioni. L'equilibrio delle forme e il contrasto dei materiali rende unico e originale l'inserimento nell'ambiente.

EN This original wood-burning stove completely covered with hand-finished Majolica makes quite an impact. The balance of forms and contrasting materials makes it unique and original.

DE Ein bühnenreifer Auftritt für einen originellen Holzofen, der komplett mit handgefertigten, großformatigen Majolika-Kacheln verkleidet ist. Die ausgewogenen Formen und kontrastierende Materialarten verleihen ihm eine einzigartige und originelle Wirkung im Raum.

FR Fort impact scénographique pour cet original poêle à bois entièrement revêtu de faïence réalisée à la main, avec des panneaux de grandes dimensions. L'équilibre des formes et le contraste des matériaux font de lui un élément décoratif unique et original.

ES Gran impacto escenográfico para una original estufa de leña, totalmente revestida de mayólica hecha a mano con paneles de grandes dimensiones. El equilibrio de las formas y el contraste de los materiales ofrece una adaptación exclusiva y original en el ambiente.

COLORI - COLOURS

Bianco Antico, Ardesia, Rosso Lava, Giallo Acceso, Sahara

cm 60 x 47 x 175

→ Specifications and colours P.170



9,0 kW
up to 260 m³

L'originale stufa-caminetto

Completamente rivestiti con pannelli in Maiolica di grande formato e forte spessore, gli Stubotti Piazzetta caratterizzano con stile ogni ambiente. Scegliere di impiegare uno Stubotto significa beneficiare della praticità di installazione di una stufa e godere della presenza scenica di un caminetto. Alcuni modelli dispongono del forno per cottura. I modelli Berna, Davos e Lugano possono essere scelti con focolari in differenti potenze, proporzioni e misure. Sono disponibili anche versioni con Multifuoco® System e sistema BCS.

EN The original stove-fireplace

Completely fitted with large, thick Majolica panels, which enhance the richness and boldness of their particular design. Piazzetta Stubotti will add a touch of style to any interior. Choosing to use a Stubotto means benefiting both from the practical installation of a stove and the beauty of a fireplace always ready to perform above your expectations. Some models also feature an oven. The Berna, Davos and Lugano models can be selected with fireboxes with different capacities, proportions and sizes. They are also available with Multifuoco® System and BCS.

FR Le poêle-cheminée original

Entièrement revêtus de panneaux en faïence de grande taille et de forte épaisseur, les Stubotti Piazzetta permettent à n'importe quel espace de se distinguer avec style. Choisir et utiliser un Stubotto signifie bénéficier de la commodité d'installation d'un poêle tout en profitant de la présence scénique d'une cheminée. Certains modèles possèdent un four de cuisson. Les modèles Berna, Davos et Lugano peuvent être choisis avec des foyers de différentes puissances, proportions et dimensions. Des versions avec système Multifuoco® et système BCS sont aussi disponibles.

DE Der originelle Kaminofen

Die komplett mit großformatigen, dickwandigen Majolika-Kacheln verkleideten Piazzetta Kaminöfen nehmen jedes Ambiente stilvoll für sich ein. Mit der Entscheidung für einen Kaminofen profitieren Sie von der praktischen Installation eines Ofens und genießen die wirkungsvolle Atmosphäre eines Kamins. Einige Modelle besitzen einen Backofen. Die Modelle Berna, Davos und Lugano können mit Heizeinsätzen in unterschiedlichen Leistungsstärken, Proportionen und Maßen ausgewählt werden. Sie sind auch mit Multifuoco® System und BCS-System erhältlich.

ES La original estufa-chimenea

Los Stubotto Piazzetta, totalmente revestidos de paneles de mayólica de formato grande y alto espesor, dan un toque de estilo a todos los ambientes. Elegir y utilizar un Stubotto quiere decir aprovechar la comodidad de instalación de una estufa y disfrutar de la presencia escénica de una chimenea. Algunos modelos cuentan con horno de cocción. Los modelos Berna, Davos y Lugano pueden elegirse con hogares de distintas potencias, proporciones y medidas. También hay disponibles versiones con Multifuoco® System y sistema BCS.

**Semplici da
installare**



Per poter scegliere l'installazione di un caminetto senza dover affrontare particolari opere murarie. La semplicità di una stufa dall'elevata capacità di riscaldamento.

EN Simple to install

To be able to choose to install a fireplace without having to carry out any serious building work. The simplicity of a stove with high heating capacity.

FR Faciles à installer

Pouvoir choisir l'installation d'une cheminée sans avoir à affronter des travaux de maçonnerie particuliers. La simplicité d'un poêle à la capacité de chauffage considérable.

DE Einfache Installation

Entscheiden Sie sich für die Installation eines Kaminofens, ohne dafür besondere Maurerarbeiten vornehmen zu müssen. Die Einfachheit eines Ofens mit hoher Heizkapazität.

ES Fáciles de instalar

Para elegir la instalación de una chimenea sin tener que abordar obras de mampostería adicionales. La sencillez de una estufa de alta capacidad de calefacción.



Multifuoco® System



Uniformità di riscaldamento in tutto l'ambiente, dal pavimento al soffitto, senza sprechi. Percepisci sempre un calore confortevole in tutto il corpo, mai più piedi freddi.

EN Multifuoco® System

Uniform heating throughout your living areas, from the floor to the ceiling. Your body will always feel warm and comfortable; no more cold feet.

FR Multifuoco® System

Uniformité de chauffage du sol au plafond, sans gaspillages. Une chaleur confortable est perçue dans tout le corps, vous n'aurez plus jamais les pieds froids.

DE Multifuoco® System

Gleichmäßige Heizung des ganzen Raums vom Fußboden bis zur Decke. Somit immer eine angenehme Wärme am ganzen Körper und keine kalten Füße.

ES Multifuoco® System

Uniformidad de calefacción en todo el ambiente, del suelo al techo, sin desperdicios. Percibe siempre un calor confortable en todo el cuerpo. Nunca más pies fríos.



Comfort e scelte di stile



Le generazioni di Stubotto si susseguono e trovano nuovi spazi. Gli originali caminetti-stufa, idea di Piazzetta, hanno saputo rimanere attuali e trovare nel tempo anche nuovi stili.

EN Comfort and style choices

Stubotto products continue to evolve and redefine their identity. The original stove-fireplaces, a Piazzetta idea, have stayed up-to-date while exploring new styles over time.

FR Confort et choix de style

Les générations de Stubotto se succèdent et conquièrent de nouveaux espaces. Les poêles-cheminées imaginés par Piazzetta ont su rester actuels et trouver de nouveaux styles.

DE Komfort und Stilbewusstsein

Neue Generationen von Kaminöfen erobern sich ihren Platz. Die originellen Kaminöfen von Piazzetta gehen mit der Zeit und sind daher stets topaktuell.

ES Confort y propuestas de estilo

Las generaciones de Stubotto se suceden y hallan nuevos espacios. Las originales chimeneas-estufa Piazzetta resultan siempre actuales y adaptan su estilo a los nuevos tiempos.





STUBOTTO C

**Nuova interpretazione dal gusto classico
attualizzato per questo Stubotto a legna dal design
con linee essenziali e armoniche. Versione con o
senza bocchetta frontale orientabile.**

EN A new interpretation of a classic style for this wood-burning Stubotto with a clean and elegant design. Available with or without directional front hot air vent.

DE Dieser Kaminofen interpretiert den klassischen Stil mit minimalistischen und harmonischen Linien auf moderne Weise neu. Vorderseite, mit oder ohne ausrichtbare Luftaustrittsöffnung.

FR Nouvelle interprétation à la saveur classique actualisée pour ce poêle-cheminée à bois aux lignes essentielles et harmonieuses. Avec ou sans grille frontale orientable.

ES Nueva interpretación con gusto clásico actualizado para este Stubotto de leña con diseño de líneas esenciales y armónicas. Versión con o sin boquilla frontal ajustable.

COLORI - COLOURS

Bianco. Bicolore - two-colour versions: **Bianco Antico/Canapa - Rosso Lava - Verde Mirto - Terra Bruna**

cm 92 x 58 x 151

→ Specifications and colours P.188



11,0 kW
up to 315 m³



DAVOS

L'originale Stufa-Caminetto dalle forme compatte e un nuovo stile moderno che caratterizza l'ambiente in cui viene installato. Rivestimento in Maiolica con pannelli di grandi dimensioni. Possono essere scelti focolari in differenti potenze, proporzioni e misure. Disponibile anche in versione BCS.

EN This original stove-fireplace with a compact shape and new modern styling adds style to any interior. Covered with large-format Majolica panels. It can be selected with fireboxes with different capacities, proportions and sizes. Also available with BCS.

DE Der originelle Kaminofen mit kompakten Formen und modernem Stil. Verkleidung aus großformatigen Majolika-Kacheln. Die Heizeinsätze sind in unterschiedlichen Leistungsstärken, Proportionen und Maßen wählbar. Auch als BCS-Version erhältlich.

FR L'original poêle-cheminée aux formes compactes et au nouveau style moderne qui distingue la pièce où il est installé. Habillage en faïence avec grands panneaux. Possibilité de choisir des foyers de différentes puissances, proportions et dimensions. Disponible également en version BCS.

ES La original estufa-chimenea de formas compactas y un nuevo estilo moderno. Revestimiento de mayólica con paneles de dimensiones grandes. Pueden elegirse hogares de distintas potencias, proporciones y medidas. Disponible también en versión BCS.

COLORI - COLOURS

Bianco, Terra Cotta, Rosso Lava, Nero Opaco

mod. MC 80/64 BL: cm 90 x 53 x 189

→ Specifications and colours P.180 - 183



11,0 kW
up to 315 m³



BERNA

Un nuovo stile moderno caratterizza questa originale Stufa-Caminetto, che personalizza l'ambiente in cui viene installata. Rivestimento in Maiolica con pannelli di grandi dimensioni. Possono essere scelti focolari in differenti potenze e misure. Disponibile anche in versione BCS.

EN This new modern stove-fireplace adds style to any interior. Covered with large-format Majolica panels. It can be selected with fireboxes with different capacities, proportions and sizes. Also available with BCS.

DE Der originelle Kaminofen in modernem Stil, der Ihrer Wohnung eine individuelle Note verleiht. Verkleidung aus großformatigen Majolika-Kacheln. Die Heizeinsätze sind in unterschiedlichen Leistungsstärken, Proportionen und Maßen wählbar. Auch als BCS-Version erhältlich.

FR Cet original poêle-cheminée se distingue par un nouveau style moderne qui personnalise la pièce où il est installé. Habillage en faïence avec grands panneaux. Possibilité de choisir des foyers de différentes puissances et dimensions. Disponible également en version BCS.

ES Un nuevo estilo moderno caracteriza esta original estufa-chimenea, que personaliza el ambiente en el cual se instala. Revestimiento de mayólica con paneles de dimensiones grandes. Pueden elegirse hogares de distintas potencias, proporciones y medidas. Disponible también en versión BCS.

COLORI - COLOURS

Bianco, Terra Cotta, Rosso Lava, Nero Opaco

mod. MC 70/51: cm 80 x 53 x 133

→ Specifications and colours P.178 - 180



11,0 kW
up to 315 m³





LUGANO

L'originale Stufa-Caminetto dall'innovativo stile moderno. È possibile scegliere anche focolari a sviluppo orizzontale per godere al massimo del piacere della visione del fuoco. Rivestito in Maiolica con pannelli di grandi dimensioni. Disponibile anche in versione con sistema BCS.

EN This original stove-fireplace has an innovative modern style. It can be selected with a horizontal firebox to get the best view of the flame. Fitted with large-format Majolica panels. Also available with BCS.

DE Origineller Kaminofen mit innovativem, modernem Stil. Sie können sich für einen Heizeinsatz mit horizontaler Ausrichtung entscheiden, um das Feuer noch besser genießen zu können. Mit großformatigen Majolika-Kacheln. Auch als Version mit BCS-System erhältlich.

FR L'original poêle-cheminée au style moderne innovant. Il est également possible de choisir des foyers à développement horizontal pour profiter au maximum du plaisir de la vision du feu. Habillage en faïence avec grands panneaux. Disponible également en version BCS.

ES La original estufa-chimenea con un estilo moderno innovador. Se pueden elegir también hogares con disposición horizontal para disfrutar plenamente del placer de la visión del fuego. Revestimiento de mayólica con paneles de dimensiones grandes. Disponible también en versión con sistema BCS.

COLORI - COLOURS

Bianco, Terra Cotta, Rosso Lava, Nero Opaco

mod. MC 105/48 BL: cm 115 x 53 x 128

→ Specifications and colours P.183 - 185





ORTISEI

Un doppio corpo in Maiolica di grandi dimensioni, su due piani, per la massima capacità di irraggiamento, per assicurare un comfort prolungato nel tempo. Bocchetta frontale uscita aria calda orientabile. Disponibile anche versione BCS.

EN A large double casing in Majolica, with two levels for maximum radiated heat output to ensure long lasting comfort. Directional front hot air vent. Also available with BCS.

DE Der doppelte Korpus mit großen Majolika-Kacheln auf zwei Ebenen sorgt für maximale Abstrahlungskapazität. Vorderseitige, ausrichtbare Luftaustrittsöffnung. Auch mit BCS-System erhältlich.

FR Double corps en faïence de grandes dimensions, sur deux étages pour maximiser le rayonnement afin d'assurer un confort prolongé. Grille de sortie d'air chaud frontale orientable. Aussi disponible en version avec système BCS.

ES Cuerpo doble de mayólica de dimensiones grandes, en dos niveles, con máxima capacidad de irradiación. Boquilla frontal ajustable de salida del aire caliente. Disponible también en versión BCS.

COLORI - COLOURS

Bianco, Canapa, Verde Mirto, Blu Verdemare, Terra Bruna,
Con decorazioni - with decorations: **Bianco Antico**

cm 100 x 58 x 147

→ Specifications and colours P.187



11,1 kW
up to 320 m³



BRUNICO

L'originale stufa-caminetto dal sapore classico con una notevole superficie di Maiolica radiante in grado di caratterizzare con stile ogni ambiente. Disponibile anche in versione con sistema BCS.

EN This original stove-fireplace has a classic feel with a large surface area of radiating Majolica. It can add character to any type of interior. Also available with BCS.

DE Origineller Kaminofen im klassischen Stil mit bemerkenswerter Strahlungsoberfläche aus Majolika, der stilvoll jedes Ambiente für sich einnimmt. Auch als Version mit BCS-System erhältlich.

FR Original poêle-cheminée à la saveur classique doté d'une grande surface en faïence rayonnante qui saura distinguer n'importe quel style d'espace. Aussi disponible en version BCS.

ES La original estufa-chimenea de gusto clásico y con una apreciable superficie de mayólica radiante que pone un toque de estilo en cualquier ambiente. Disponible también en versión con sistema BCS.

COLORI - COLOURS

Bianco. Bicolore - two-colour versions: **Bianco Antico / Blu Verdemare - Canapa - Terra Bruna - Verde Mirto**

cm 73 x 58 x 146

→ Specifications and colours P.186



11,1 kW
up to 320 m³



CANAZEI

Richiama il design delle classiche stufe in Maiolica adottando un focolare di elevata efficienza. Ampia superficie in Maiolica. Bocchetta frontale uscita aria calda orientabile. Disponibile anche in versione con sistema BCS.

EN This model reflects the classic Majolica stoves, using a high-efficiency firebox. The large Majolica surfaces. Directional front hot air vent. Also available with BCS.

DE Er erinnert an das Design der traditionellen Kachelöfen und besitzt einen leistungsstarken Heizeinsatz. Große Majolika-Oberflächen. Vorderseitige, ausrichtbare Luftaustrittsöffnung. Auch mit BCS-System erhältlich.

FR Il rappelle le design des poêles classiques en faïence, mais avec un foyer à haut rendement. Grande surface en faïence. Grille de sortie d'air chaud frontale orientable. Aussi disponible en version avec système BCS.

ES Evoca el diseño de las estufas clásicas de mayólica adoptando un hogar de alta eficiencia. Amplia superficie de mayólica. Boquilla frontal ajustable de salida del aire caliente. Disponible también en versión con sistema BCS.

COLORI - COLOURS

Bianco, Canapa, Verde Mirto, Blu Verdemare, Terra Bruna,
Con decorazioni - with decorations: **Bianco Antico**

cm 75 x 59 x 147

→ Specifications and colours P.186 - 187



11,1 kW
up to 320 m³

Per riscaldarsi e cucinare

Il calore del fuoco a legna viene impiegato per riscaldare uno o più ambienti e, grazie alla presenza di un forno posto sulla parte superiore della stufa, anche per cucinare le pietanze.

È così possibile ritornare ad abitudini che sono nella nostra memoria e cuocere, in modo naturale, con il calore della stufa a legna. Il forno è interamente rivestito in acciaio inox ed è provvisto di termometro per la rilevazione della temperatura. Alla funzionalità d'uso e alle notevoli prestazioni si affianca il design valorizzato da un rivestimento in Maiolica.

EN For heating and cooking

The warmth of a wood fire can be used to heat one or more rooms with the Multifuoco system and, thanks to the oven situated above the stove, it can also be used for cooking. Yes, cooking! This stove allows us to return to the ways of the past and cook with the natural heat of a wood-burning stove. The oven is entirely lined in stainless steel and equipped with a thermometer. As well as being functional and easy to use, it also boasts a great design and Majolica cladding. This stove is a double pleaser not to mention a money saver and a helper in the kitchen.

FR Pour se chauffer et cuisiner

La chaleur du feu de bois est exploitée pour chauffer une ou plusieurs pièces, mais aussi pour cuisiner grâce à la présence d'un four dans la partie supérieure du poêle. Il est ainsi possible de revenir à des habitudes oubliées et de cuisiner de manière naturelle avec la chaleur du poêle à bois. Le four est entièrement revêtu d'acier inox et doté d'un thermomètre qui mesure la température. La fonctionnalité d'utilisation et les performances considérables s'accompagnent d'un design mis en valeur par un revêtement en faïence.

DE Zum Heizen und Kochen

Die Hitze des Holzfeuers dient der Erwärmung von einem oder mehreren Räumen und, dank des Backofens auf dem Ofen, dem Garen von Gerichten. Dies ist die Rückkehr in alte Zeiten, in denen ganz natürlich mit der Wärme des Holzofens gekocht wurde. Der Ofen ist komplett mit Edelstahl verkleidet und besitzt ein Thermometer zur Temperaturermittlung. Die Gebrauchsfunktionen und die bemerkenswerten Leistungen werden um das Design mit edler Majolika-Verkleidung ergänzt.

ES Para calentarse y cocinar

El calor del fuego de leña se utiliza para calentar uno o varios ambientes y, gracias a la presencia de un horno situado en la parte superior de la estufa, también para cocinar alimentos. De esta forma podemos regresar a las costumbres que viven en nuestra memoria y cocinar, de forma natural, con el calor de la estufa de leña. El horno está totalmente revestido de acero inoxidable y cuenta con termómetro para verificar la temperatura. A la funcionalidad de uso y a las altas prestaciones se une un diseño valorizado por un revestimiento de mayólica.



Un piacevole ritorno in cucina



La visione di un fuoco in cucina ritornerà a portare gioia e vitalità a tutta la famiglia che si riunirà attorno a esso, lasciando che nell'attesa sia il fuoco a cucinare le pietanze.

EN A pleasant return to the kitchen

The sight of a fire in the kitchen will bring joy and vitality to all the family, who will gather around it, letting the fire cook meals while they wait.

FR Un agréable retour en cuisine

La vision d'un feu dans la cuisine apportera la joie et la vitalité à toute la famille, qui se rassemblera autour de lui, en lui laissant le temps de cuire les plats.

DE Eine erfreuliche Rückkehr in die Küche

Der Anblick des Feuers in der Küche bringt der ganzen Familie, die sich darum versammelt und das Garen der Speisen dem Feuer überlässt, erneut Freude und Lebendigkeit.

ES Un agradable regreso a la cocina

Un hogar en tu cocina brinda alegría y vitalidad a toda la familia reunida que espera mientras cocinas la comida en el fuego.



Cottura con valvola anticondensa



Il forno garantisce una cottura sana anche grazie alla presenza di una valvola anticondensa che farà fuoriuscire il vapore e la condensa che dovesse crearsi durante la cottura.

EN Cooking with an anti-condensation valve

The oven guarantees healthy cooking also thanks to the presence of an anti-condensation valve, which releases any steam and condensation created during cooking.

FR Cuisson avec vanne anti-condensation

Le four garantit une cuisson saine grâce à une vanne anti-condensation qui permettra à la vapeur et au condensat qui pourraient se créer de s'échapper pendant la cuisson.

DE Kochen mit Kondensatventil

Der Ofen gewährleistet dank des eingebauten Kondensatventils zur Ableitung von Dampf und Kondensat, die sich während des Garvorgangs bilden, eine absolute gesunde Zubereitung.

ES Cocción con válvula anticondensación

El horno asegura una cocción saludable gracias a la válvula anticondensación que permite descargar el vapor acumulado durante la cocción.

Multifuoco® System



Uniformità di riscaldamento in tutto l'ambiente, dal pavimento al soffitto, senza sprechi. Percepisci sempre un calore confortevole in tutto il corpo, mai più piedi freddi.

EN Multifuoco® System

Uniform heating throughout your living areas, from the floor to the ceiling. Your body will always feel warm and comfortable; no more cold feet.

FR Multifuoco® System

Uniformité de chauffage du sol au plafond, sans gaspillages. Une chaleur confortable est perçue dans tout le corps, vous n'aurez plus jamais les pieds froids.



Maiolica



L'esclusiva lavorazione artigianale di pezzi unici in Maiolica, che si plasmano a mano, e con sapiente maestria, caratterizzano e distinguono le stufe e tutti i prodotti Piazzetta.

EN Majolica

The exclusive and unique hand-crafted Majolica, which is formed by hand by expert craftsmen, characterises and distinguishes Piazzetta stoves and products.

FR Faïence

Les pièces uniques en faïence, modelées à la main avec une maîtrise artisanale soignée et exclusive, distinguent les poêles et tous les produits Piazzetta.

DE Majolika

Die Öfen und die anderen Produkte von Piazzetta zeichnen sich durch die exklusive Verarbeitung der Einzelstücke aus Majolika, die meisterhaft von Hand geformt werden, aus.

ES Mayólica

El exclusivo trabajo artesanal de las piezas únicas en mayólica, trabajadas a mano con maestría, caracterizan y distinguen las estufas y todos los productos Piazzetta.



DE Multifuoco® System

Gleichmäßige Heizung des ganzen Raums vom Fußboden bis zur Decke. Somit immer eine angenehme Wärme am ganzen Körper und keine kalten Füße.

ES Multifuoco® System

Uniformidad de calefacción en todo el ambiente, del suelo al techo, sin desperdicios. Percibe siempre un calor confortable en todo el cuerpo. Nunca más pies fríos.



E911

Elegante e raffinata, questa stufa a legna offre una originale soluzione per il riscaldamento di un ambiente consentendo anche il pratico utilizzo di un forno in acciaio inox dotato di termometro, per la cottura delle pietanze. Rivestimento in Maiolica.

EN Elegant and refined, this wood-burning stove offers an original solution for heating rooms. It also contains a practical stainless steel oven fitted with a thermometer for cooking. Majolica cladding.

DE Dieser elegante und raffinierte Holzofen bietet eine originelle Heizlösung für einen Raum an mit gleichzeitiger praktischer Nutzung eines Edelstahlrofens mit Thermometer zum Zubereiten von Speisen. Verkleidung aus Majolika.

FR Élégant et raffiné, ce poêle à bois offre une solution originale pour chauffer une pièce mais aussi pour cuire des aliments grâce à un four en acier inox avec thermomètre. Habillage en faïence.

ES Elegante y refinada, esta estufa de leña propone una solución original para la calefacción de un ambiente y ofrece además un práctico horno de acero inoxidable provisto de termómetro, para la cocción de los alimentos. Revestimiento de mayólica.

COLORI - COLOURS

Bianco Meringa, Beige Sabbia, Blu Antico, Bordeaux

cm 56 x 47 x 135

→ Specifications and colours P.149



E911 Beige Sabbia



E911 Bordeaux



E900 M

L'elevata potenza termica rende questa stufa a legna la soluzione giusta per riscaldare grandi spazi. Il pratico forno, in acciaio inox con valvola vapore e termometro, garantisce ottimi risultati di cottura. Rivestimento in Maiolica. Bocchetta di ventilazione frontale orientabile.

EN The high heating power of this wood-burning stove is the ideal solution for heating large spaces. The practical oven in stainless steel with steam valve and thermometer ensures excellent cooking results. Majolica cladding. Directional front hot air vent.

DE Die hohe Wärmeleistung macht diesen Holzofen zur richtigen Lösung zum Beheizen von großen Räumen. Der praktische Edelstahlbackofen mit Dampfventil und Thermometer garantiert optimale Kochergebnisse. Verkleidung aus Majolika. Vorderseitige, ausrichtbare Luftöffnung.

FR La haute puissance thermique de ce poêle fait de lui la solution idéale pour les grands espaces. Le four très pratique en acier inox, avec soupape de vapeur et thermomètre, garantit d'excellents résultats de cuisson. Habillage en faïence. Grille de ventilation frontale orientable.

ES La alta potencia térmica hace de esta estufa de leña la solución ideal para calentar grandes espacios. El práctico horno de acero inoxidable, con válvula de vapor y termómetro, garantiza excelentes resultados de cocción. Revestimiento de mayólica. Boquilla de ventilación frontal ajustable.

COLORI - COLOURS

Bianco Antico, Terra Oriente, Rosso

cm 78 x 63 x 146

→ Specifications and colours P.149



13,0 kW
up to 375 m³

Una originale gamma di stufe a legna caratterizzate da un rivestimento in acciaio e il piano superiore in acciaio con inserti in Maiolica. La varietà dei modelli è in grado di soddisfare molteplici necessità di stile d'ambiente garantendo il massimo comfort di riscaldamento con un elevato impatto estetico. Sono disponibili anche con il focolare ermetico. Alcune versioni possono accogliere un kit di prelievo dell'aria comburente dall'esterno, disporre del controllo elettronico della combustione BCS o del sistema di accumulo HSS.

EN An original range of wood-burning stoves characterised by steel cladding and an upper steel top with majolica inserts. The variety of available models can satisfy a diverse range of room styles, guaranteeing the utmost heating comfort coupled with a striking visual impact. Versions with an airtight firebox are also available. Certain versions can also mount a kit for drawing combustion air from the outside, besides an electronic combustion control system (BCS) or the heat storage system (HSS).

DE Eine originelle Holzofen-Produktlinie, die sich durch eine Stahlverkleidung und eine Abdeckplatte aus Stahl mit Majolika-Einsätzen auszeichnet. Dank der Vielzahl an Modellen können zahlreiche Anforderungen an den Raumstil erfüllt und maximaler Heizkomfort mit einer hohen ästhetischen Wirkung gewährleistet werden. Die Öfen sind auch mit einem raumluftunabhängigen Heizeinsatz erhältlich. Einige Ausführungen können mit einem Set für die Zufuhr von Verbrennungsluft von außen ausgestattet werden bzw. über die elektronische Verbrennungssteuerung BCS oder das Wärmespeichersystem HSS verfügen.

FR Une gamme originale de poêles à bois caractérisée par un revêtement en acier et un plateau supérieur en acier avec inserts en faïence. La variété des modèles est en mesure de répondre aux multiples exigences de style de la pièce, en garantissant à la fois un confort de chauffage optimal et un fort impact esthétique. Ils sont également disponibles avec foyer étanche. Certaines versions peuvent accueillir un kit de prélèvement de l'air comburant à l'extérieur, disposer d'un contrôle électronique de la flamme BCS ou d'un système d'accumulation HSS.

ES Una original gama de estufas de leña con revestimiento de acero y superficie superior de acero con aplicaciones de mayólica. La variedad de modelos responde a numerosas necesidades de estilo garantizando el máximo confort de calefacción con un alto impacto estético. Disponibles también con hogar hermético. Algunas versiones permiten instalar un kit de toma de aire de combustión exterior y disponer del control electrónico de la combustión BCS o del sistema de acumulación HSS.



Massima efficienza



La progettazione di un focolare di ultima generazione consente di ottenere alti rendimenti. Elevata resa termica e calore in ambiente con un ridotto carico di legna.

EN Maximum efficiency
The design of the new generation firebox offers excellent levels of efficiency. High heat output and warmth in the room with reduced wood consumption.

FR Efficacité maximale
La conception d'un foyer de dernière génération permet d'obtenir des rendements élevés. Rendement thermique élevé et chaleur dans la pièce avec un chargement en bois réduit.

DE Maximale Effizienz
Der moderne Heizeinsatz gewährleistet die Erzielung hoher Leistungswerte. Eine hohe Wärmeleistung und wohlige Wärme des Raums mit einer verringerten Holzfüllung.

ES Máxima eficiencia
El alto rendimiento se obtiene gracias al diseño de un hogar de última generación. Un alto rendimiento térmico y un fuerte calor en el ambiente con una baja carga de leña.



BCS Gestione elettronica



Massimo comfort di impiego grazie alla regolazione automatica della fiamma a legna, gestita con controllo elettronico da telecomando. Combustione perfetta, elevati rendimenti.

EN BCS electronic control

Maximum comfort thanks to automatic wood flame regulation, electronically controlled via remote control. Perfect combustion, high efficiency.

FR BCS Gestion électronique

Confort d'utilisation grâce au réglage automatique de la flamme, géré avec contrôle électronique par télécommande. Une combustion parfaite, hauts rendements.

DE BCS Elektronische Steuerung

Maximale Bedienerfreundlichkeit dank der automatischen Flammenregelung, die über eine elektronische Fernbedienung gesteuert wird. Perfekte Verbrennung, hohe Leistungswerte.

ES Gestión electrónica BCS

Máximo confort gracias a la regulación automática de la llama con un control electrónico mediante mando a distancia. Combustión perfecta, alto rendimiento.

Multifuoco® System



Uniformità di riscaldamento in tutto l'ambiente, dal pavimento al soffitto, senza sprechi. Percepisci sempre un calore confortevole in tutto il corpo, mai più piedi freddi.

EN Multifuoco® System

Uniform heating throughout your living areas, from the floor to the ceiling. Your body will always feel warm and comfortable; no more cold feet.

FR Multifuoco® System

Uniformité de chauffage du sol au plafond, sans gaspillages. Une chaleur confortable est perçue dans tout le corps, vous n'aurez plus jamais les pieds froids.



HSS Heat Storage System



Il piacere del calore si prolunga per ore anche dopo lo spegnimento del fuoco. Un modo naturale e salutare per incrementare il benefico riscaldamento per irraggiamento.

EN HSS Heat Storage System

The pleasure of the warmth is prolonged for hours after the flames go out. A natural and healthy way to increase the beneficial effect of radiated warmth.

DE HSS Heat Storage System

Die angenehme Wärme hält nach dem Erlöschen des Feuers noch einige Stunden an. Eine natürliche und gesunde Art, die Vorzüge einer Heizung durch Wärmeabstrahlung zu erhöhen.

FR HSS Heat Storage System

Le plaisir de la chaleur se prolonge des heures après l'extinction du feu. Une façon naturelle et salubre pour augmenter le bénéfice d'un chauffage par rayonnement.

ES HSS Heat Storage System

El placer del calor se prolonga durante horas incluso después de apagar el fuego. Una manera natural y saludable para aumentar los beneficios de la calefacción por radiación.



DE Multifuoco® System

Gleichmäßige Heizung des ganzen Raums vom Fußboden bis zur Decke. Somit immer eine angenehme Wärme am ganzen Körper und keine kalten Füße.

ES Multifuoco® System

Uniformidad de calefacción en todo el ambiente, del suelo al techo, sin desperdicios. Percibe siempre un calor confortable en todo el cuerpo. Nunca más pies fríos.



E124

Design essenziale e lineare. Forme che si inseriscono in differenti soluzioni di arredo. Stufa a legna con rivestimento in acciaio. Il vetro curvo a porta offre massima visione del fuoco e un design esclusivo. Focolare ermetico, disponibile anche in versione con sistema BCS.

EN Sober and linear design. Forms that blends into a variety of furnishing styles. Wood-burning stove with steel cladding. The curved glass flush with the door combines maximum visibility of the fire and exclusive design. Airtight firebox, also available with the BCS system.

DE Schlichtes und lineares Design. Formen, die sich in die unterschiedlichsten Einrichtungsstile einfügen. Holzofen mit Stahlverkleidung. Die gewölbte Glastür bietet eine großzügige Sicht auf das Feuer und ein exklusives Design. Raumluftunabhängiger Heizeinsatz, auch in der Ausführung mit BCS-System erhältlich.

FR Design essentiel et linéaire. Des formes qui s'intègrent à différentes solutions d'aménagement. Poêle à bois avec revêtement en acier. La vitre incurvée affleurante offre une vision maximale du feu et un design exclusif. Foyer étanche, disponible également dans la version avec système BCS.

ES Diseño esencial y lineal. Formas que se incorporan en diferentes soluciones de decoración. Estufa de leña con revestimiento de acero. Vidrio curvo a ras de la puerta para la máxima vista del fuego y un diseño exclusivo. Hogar hermético, disponible también en versión con sistema BCS.

COLORI - COLOURS

Bianco Opaco, Nero Opaco

cm 49 x 49 x 115

→ Specifications and colours P.172

7,2 kW
up to 210 m³





E124 A

Posizione rialzata del focolare per questa piacevole stufa a legna dal particolare design. Rivestimento in acciaio. Vetro curvo a filo porta per una massima visione del fuoco. Focolare ermetico, disponibile anche in versione con sistema a controllo elettronico della combustione BCS.

EN Raised position for the firebox mounted in this visually appealing wood-burning stove featuring an original design. Steel cladding. Door with flush curved glass for maximum view of the fire. Airtight firebox, also available in the version with the BCS electronic combustion control system.

DE Erhöhte Position des Heizeinsatzes für diesen schönen Holzofen mit dem außergewöhnlichen Design. Stahlverkleidung. Gewölbte Glastür für eine optimale Sicht auf das Feuer. Raumlufunabhängiger Heizeinsatz, auch in der Ausführung mit elektronischer Flammensteuerung BCS erhältlich.

FR Position rehaussée du foyer pour ce poêle à bois agréable et au design original. Revêtement en acier. Vitre incurvée affleurante pour une vision maximale du feu. Foyer étanche, disponible également dans une version avec système de contrôle électronique de la flamme BCS.

ES Agradable estufa de leña de diseño especial con hogar realizado. Revestimiento de acero. Vidrio curvo a ras de la puerta para la máxima vista del fuego. Hogar hermético, disponible también en versión con sistema de control electrónico de la combustión BCS.

COLORI - COLOURS

Bianco Opaco, Nero Opaco

cm 49 x 49 x 125

→ Specifications and colours P.172 - 173





E128

Stufa dalle geometrie rigorose, rivestita in acciaio, piano superiore acciaio e Maiolica. Riscalda l'ambiente per convezione naturale e irraggiamento. Bocchetta frontale di uscita aria calda orientabile. Disponibile anche in versione ermetica, con prelievo dell'aria comburente dall'esterno e con sistema BCS.

EN A steel-clad stove featuring a rigorous design, with steel and majolica upper top. Heats the environment through natural convection and radiation. Adjustable front vent for hot air. Also available in an airtight version with combustion air drawn from the outside and with the BCS System.

DE Ofen mit strengen Linien, mit Stahlverkleidung und Abdeckplatte aus Stahl und Majolika. Er wärmt den Raum mit natürlicher Konvektion und Strahlungswärme. Schwenkbare Warmluft-Austrittsöffnung vorne. Auch in raumluftunabhängiger Ausführung, mit Zufuhr von Verbrennungsluft von außen und mit BCS-System erhältlich.

FR Poêle aux géométries rigoureuses, revêtu en acier, plateau supérieur acier et faïence. Il chauffe la pièce par convection naturelle et rayonnement. Bouche de sortie d'air chaud avant orientable. Disponible également en version étanche, avec prélèvement de l'air comburant à l'extérieur et avec système BCS.

ES Estufa de geometrías rigurosas, revestida de acero, superficie superior de acero y mayólica. Calienta el ambiente por convección natural e irradiación. Boca frontal orientable para la salida del aire caliente. Disponible también en versión hermética, con toma del aire de combustión del exterior y con sistema BCS.

COLORI - COLOURS

Bianco Opaco, Nero Opaco

cm 57 x 45 x 127

→ Specifications and colours P.173 - 174

11,0 kW
up to 315 m³





E128 A

Stufa dall'originale equilibrio di design, focolare rialzato per apprezzare maggiormente la bellezza del fuoco. Rivestimento in acciaio. Bocchetta frontale uscita aria calda orientabile. Disponibile anche in versione ermetica, con prelievo dell'aria comburente dall'esterno, e con sistema BCS.

EN A stove featuring an original harmonious design with a raised firebox to further appreciate the fire's beauty. Steel cladding. Adjustable front vent for hot air. Also available in an airtight version with combustion air drawn from the outside and with the BCS System.

DE Ofen mit einem ausgewogenen und originellen Design mit erhöhtem Heizeinsatz, der die Schönheit des Feuers noch zusätzlich unterstreicht. Stahlverkleidung. Schwenkbare Warmluft-Austrittsöffnung vorn. Auch in raumluftunabhängiger Ausführung, mit Ansaugung der Verbrennungsluft von außen und mit BCS-System erhältlich.

FR Poêle au design équilibré et original, foyer rehaussé pour apprécier encore davantage la beauté du feu. Revêtement en acier. Bouche de sortie d'air chaud avant orientable. Disponible également en version étanche, avec prélèvement de l'air comburant à l'extérieur et avec système BCS.

ES Estufa de un original diseño equilibrado, con hogar realzado, para apreciar mejor la belleza del fuego. Revestimiento de acero. Boca frontal orientable para la salida del aire caliente. Disponible también en versión hermética, con toma de aire de combustión exterior y con sistema BCS.

COLORI - COLOURS

Bianco Opaco, Nero Opaco

cm 57 x 45 x 141

→ Specifications and colours P.174 - 175

11,0 kW
up to 315 m³





E129 M

Stufa a legna moderna, dalla classica sezione tonda. Esprime con il suo equilibrio la capacità di essere una valida soluzione di arredo per ambienti di stile. Rivestimento in acciaio. Vetro curvo a filo porta. Bocchetta frontale uscita aria calda orientabile. Anche in versione con sistema BCS.

EN A modern wood-burning stove featuring the conventional round cross-section. Thanks to its harmonious design, this stove makes an optimal furnishing solution for stylish settings. Steel cladding. Door with flush curved glass. Adjustable front vent for hot air. Also available with the BCS system.

DE Moderner Holzofen mit klassischem rundem Querschnitt. Er fügt sich mit seinem ausgewogenen Design auch in die stilvollsten Wohnräume ein. Stahlverkleidung. Gewölbte Glastür. Schwenkbare Warmluft-Austrittsöffnung vorn. Auch als Version mit BCS-System.

FR Poêle à bois moderne, de section ronde classique. Ce poêle parfaitement équilibré peut constituer une solution décorative adaptée pour créer des environnements stylés. Revêtement en acier. Vitre incurvée affleurante. Bouche de sortie d'air chaud avant orientable. Disponible également en version avec système BCS.

ES Estufa de leña moderna, de clásica sección circular. Expresa con su equilibrio la capacidad de ser una solución de decoración válida para ambientes de estilo. Revestimiento de acero. Vidrio curvo a ras de la puerta. Boca frontal orientable para la salida del aire caliente. También en versión con sistema BCS.

COLORI - COLOURS

Bianco Opaco, Nero Opaco

cm 57 x 57 x 119

→ Specifications and colours P.176 - 177



7,9 kW
up to 230 m³

Maiolica in oltre 40 tonalità, anche su richiesta

La lavorazione artigianale della Maiolica, effettuata nel nostro stabilimento interno, ci consente di offrire la più ampia scelta di colori per i rivestimenti delle nostre stufe. Ogni prodotto viene proposto nei suoi colori di serie, ma può essere richiesto anche nel colore che preferisci. Perché la nostra produzione è fatta di soli "pezzi unici". L'esperienza della lavorazione e la cura per i particolari ci contraddistinguono, l'originalità ci fa riconoscere.

EN Majolica offered in over 40 shades, even on request.

The artisan processing of the Majolica, realized in-house at our plant, enables us to offer a broad assortment of colours for our stove claddings. Each product is proposed in its standard colours, but can be requested in preferential colours, because our production is made up of "single pieces".

Processing expertise and finely worked details distinguish our products, making them unique.

FR Faïence disponible dans plus de 40 teintes, sur demande aussi.

Le façonnage artisanal de la Faïence, effectué dans notre usine, nous permet d'offrir un très vaste choix de couleurs pour les habillages de nos poêles. Chaque produit est proposé dans ses coloris de série, mais il peut également être commandé dans le coloris que vous préférez. Car notre production compte uniquement des « pièces uniques ». Le savoir-faire et le soin des détails nous caractérisent, l'originalité fait qu'on nous reconnaît.

DE Majolika in über 40 Farben, auch auf Anfrage.

Die handwerkliche Bearbeitung der Majolika erfolgt in unserer hauseigenen Manufaktur, wodurch wir ein umfassendes Farbspektrum für die Verkleidung unserer Öfen anbieten können. Jedes Produkt ist in den vorgesehenen serienmäßigen Farben erhältlich, kann aber auch als Sonderglasur bestellt werden, da unsere Produktion ausschließlich handgemachte Majolika fertigt. Erfahrung in der Bearbeitung, sorgfältige Auswahl der Komponenten und Originalität sind unsere Erkennungszeichen.

ES Mayólica en más de 40 colores, incluso bajo petición.

La elaboración artesanal de la Mayólica, efectuada internamente en fábrica, permite ofrecer la más amplia gama de colores para los revestimientos de nuestras estufas. Cada producto se propone en sus colores de serie, pero también se pueden pedir colores especiales. Porque nuestra producción se compone de "piezas únicas". Nos distinguen la experiencia de la elaboración, el cuidado de los detalles y la originalidad.





Bianco



Bianco
Meringa



Bianco
Antico



Bianco
Grigio



Grigio
Cerato



Grigio
Ferro



Crema



Cipria



Sahara



Beige
Sabbia



Terra
Cotta

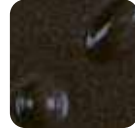

Moka



Kaki



Canapa



Terra
Bruna



Verde
Mirto



Ardesia



Nero
Opaco



Giallo
Acceso



Terra
Oriente



Rosso



Rosso
Lava



Bordeaux



Tè
Verde



Anice



Blu
Verdemare



Blu
Antico

Acciaio - Steel - Acier - Stahl - Acero



Bianco



Bianco
Opaco



Corten



Nero
Opaco



Nero

Caratteristiche

STRUCTURE AND COSTRUCTION



La solidità delle stufe a legna Piazzetta garantisce una lunga durata nel tempo, mantenendo elevate le prestazioni che caratterizzano i nostri prodotti realizzati esclusivamente con componenti di qualità.

EN Structure and build

The solidity of Piazzetta stoves ensures a long life, maintaining the high levels of performance that characterise our products, which are made exclusively from high-quality components.

FR Structure et construction

La solidité des poêles à bois Piazzetta leur garantit une longue durée de vie avec les performances élevées qui caractérisent nos produits réalisés exclusivement avec des composants de qualité.

DE Struktur und Konstruktion

Die solide Struktur der Piazzetta Holzöfen garantiert eine lange Lebensdauer mit anhaltend hohen Leistungen, die unsere ausschließlich aus Qualitätsbauteilen hergestellten Produkte auszeichnet.

ES Estructura y fabricación

La solidez de las estufas de leña Piazzetta garantiza la durabilidad de las mismas y conserva el alto rendimiento típico de nuestros productos, hechos exclusivamente con componentes de alta calidad.



FUNCTIONAL BRAZIER



Il braciere ampio e profondo assicura massima praticità nell'utilizzo e più spazio per la raccolta delle braci. L'ingresso dell'aria è calibrato per la miglior combustione e massima piacevolezza della fiamma.

EN Practical brazier

The wide and deep brazier ensures maximum practicality and more space for collecting the embers. The air inlet is calibrated for combustion efficiency and maximum flame benefit.

FR Brasier pratique

Le brasier large et profond est extrêmement pratique lors de l'utilisation du poêle et du retrait des braises. L'entrée de l'air est calibré pour assurer la meilleure combustion et les plus belles flammes.

DE Praktischer Brenntopf

Der große und tiefe Brenntopf gewährleistet höchsten Komfort bei der Bedienung und mehr Platz für die Glut. Der Lufteinlass ist auf eine bessere Verbrennung und maximale Ästhetik der Flamme ausgerichtet.

ES Práctico brasero

El brasero amplio y profundo asegura máxima facilidad de uso y más espacio para la recogida de las brasas. La entrada del aire se calibra para mejorar la combustión y maximizar el confort de la llama.



SUPERIOR THICKNESS



Indeformabili nel tempo, provviste di robuste cerniere e pratiche maniglie, le porte delle stufe dotate di esclusiva guarnizione in fibroceramica e rete d'acciaio garantiscono una perfetta chiusura.

EN Door opening

The stove doors are fitted with strong hinges and practical handles and will not deform over time. They are also fitted with exclusive ceramic-fibre seals and a steel mesh to ensure perfect closure.

FR Ouverture de la porte

Indéformables dans le temps, avec leurs charnières robustes et leurs poignées pratiques, les portes des poêles dotées d'un joint exclusif en fibre céramique et filet d'acier assurent une fermeture parfaite.

DE Türöffnung

Die mit robusten Scharnieren versehenen Ofentüren sind praktisch nicht verformbar und garantieren dank der stahlnetzverstärkten Keramikfaserdichtung um eine perfekte Schließung.

ES Apertura de la puerta

Las puertas de las estufas, indeformables a lo largo del tiempo, provistas de sólidas bisagras, prácticos tiradores y la exclusiva junta de fibra de cerámica y malla de acero, garantizan un cierre perfecto.



CONTINUOUS FIRE



L'elevata efficienza e la generosa capienza del focolare, anche grazie a una puntuale regolazione della combustione, manuale o con BCS, vantano una eccezionale autonomia di funzionamento tra una carica e l'altra.

EN Operating autonomy

The high efficiency and generous capacity of the firebox allow for an exceptional level of operating autonomy. This is also thanks to precise combustion regulation, via manual control or BCS.

FR Autonomie de fonctionnement

Le haut rendement et la taille généreuse du foyer, ainsi que la régulation ponctuelle de la combustion, manuelle ou par BCS, garantissent une autonomie de fonctionnement exceptionnelle.

DE Betriebsautonomie

Hohe Effizienz und großzügiger Feuerraum. Sie weisen dank einer präzisen manuellen oder per BCS einstellbaren Verbrennung eine ausgezeichnete Betriebsautonomie auf.

ES Autonomía de funcionamiento

La alta eficiencia y la generosa capacidad del hogar, gracias también a la regulación precisa de la combustión, ya sea manual o con BCS, hacen alarde de una autonomía de funcionamiento extraordinaria.



EASY TO CLEAN



Un capiente cassetto di raccolta della cenere in acciaio verniciato di elevato spessore, comodamente estraibile e semplice da svuotare, rende particolarmente agili e pratiche le operazioni di pulizia.

EN Removable ash tray

The spacious ash tray in painted steel is extra thick. It is easy to remove and empty, making cleaning operations quick and easy.

FR Tiroir à cendres coulissant

Grâce au grand tiroir à cendres en acier peint de forte épaisseur, coulissant et simple à vider, les opérations de nettoyage sont particulièrement faciles et pratiques.

DE Ausziehbarer Aschekasten

Aschekasten mit großem Fassungsvermögen aus lackiertem Stahl mit hoher Wanddicke, bequem ausziehbar und leicht auszuleeren, für besonders einfaches Reinigen.

ES Cajón de cenizas extraíble

Un espacioso cajón de cenizas de acero pintado de alto espesor, fácil de extraer y de vaciar, agiliza al máximo las operaciones de limpieza.



GLASS CLEANING



L'ampio vetro delle stufe Piazzetta consente la migliore visione della fiamma per il massimo piacere del fuoco. Il vetro viene mantenuto costantemente pulito internamente grazie a un flusso d'aria.

EN Glass cleaning

The large glass on Piazzetta stoves ensures an improved view of the flame to fully enjoy the pleasure of fire. The inside of the glass is kept constantly clean thanks to a wall of air flow.

FR Nettoyage de la vitre

La grande vitre des poêles Piazzetta permet une pleine vision de la flamme pour jouir du plaisir du feu. Le verre est balayé constamment par un flux d'air qui contribue à la maintenir propre.

DE Reinigung der Glasscheibe

Die große Scheibe der Piazzetta-Öfen bietet eine optimale Sicht auf die Flamme und vermittelt die heimelige Wärme des Feuers. Ein konstanter Luftstrom sorgt für die Reinigung der Scheiben-Innenseite.

ES Limpieza del vidrio

El amplio vidrio de las estufas Piazzetta ofrece una excelente vista de la llama, para aprovechar el máximo placer del fuego. El vidrio se limpia constantemente en el interior gracias a un flujo de aire.



Caratteristiche

WIDE SCREEN FIRE



Una stufa Piazzetta è sinonimo di qualità ma anche di piacere per il design e per lo spettacolo emozionante che il fuoco sa donare. Per questo il vetro è particolarmente ampio.

EN Broad view of the flame

A Piazzetta stove is synonymous with quality but also with design and the exciting spectacle of the flame. For this reason the glass panel is particularly wide.

FR Large vision de la flamme

Un poêle Piazzetta est synonyme de qualité mais également de plaisir, grâce à son design et au spectacle exceptionnel qu'offre le feu. C'est pour cela que la vitre est particulièrement large.

DE Panoramascheibe

Ein Piazzetta Ofen steht für Qualität, aber auch für angenehmes Design und ein emotionsgeladenes Schauspiel, das uns das Feuer beschert. Aus diesem Grund ist die Scheibe besonders breit.

ES Amplia vista de la llama

Una estufa Piazzetta es sinónimo de calidad pero también de placer gracias al diseño y al emocionante espectáculo que solo el fuego sabe regalar. Por este motivo, el vidrio es particularmente amplio.



PERFORMANCE IMPROVING



È possibile migliorare ulteriormente la combustione e il rendimento della stufa prelevando l'aria comburente dall'esterno, grazie a un kit di collegamento. Evitando di consumare ossigeno in ambiente.

EN Combustion air

Combustion and stove efficiency can be further improved by drawing air from the outside using a connection kit. This avoids consuming oxygen within the room.

FR Amélioration des performances

Il est possible d'améliorer encore la combustion et le rendement du poêle en prélevant l'air comburant à l'extérieur, grâce à un kit de raccordement. Cela évite de consommer l'oxygène présent dans la pièce.

DE Verbesserte Leistung

Mit Hilfe der Luftzuführung von außen kann die Verbrennung und die Ofenleistung dank eines Anschlusskits merklich verbessert werden. So wird kein Sauerstoff aus dem Raum verbraucht.

ES Mejora del desempeño

Es posible mejorar aún más la combustión y el rendimiento de la estufa tomando el aire comburente del exterior, gracias a un kit de conexión. De esta forma se evita el consumo del oxígeno del ambiente.



BEST FIRE EFFICIENCY



Un sistema di aria terziaria preriscaldata, presente in molti modelli, ottimizza ulteriormente la combustione, assicurando rendimenti elevati e basse emissioni in atmosfera.

EN Tertiary air system

A preheated tertiary air system optimises combustion, fitted on many models, ensures high performance and low emissions into the atmosphere.

FR Meilleur rendement du feu

Le système d'air tertiaire préchauffé qui équipe de nombreux modèles, optimise encore plus la combustion, assurant ainsi des rendements élevés et de faibles émissions dans l'atmosphère.

DE Beste Befeuerungseffizienz

Das System der vorgewärmten Tertiärluft, mit dem viele Modelle ausgestattet sind, optimiert die Verbrennung noch weiter und garantiert hohe Leistungen sowie geringe Emissionen.

ES Máxima eficiencia de combustión

El sistema de aire terciario precalentado, presente en muchos modelos, optimiza la combustión aún más asegurando rendimientos elevados y bajas emisiones a la atmósfera.



HUMIDIFIER



Il massimo comfort in ambiente si raggiunge con l'impiego dell'umidificatore con vasca in acciaio inox. L'aggiunta di fragranze profumate consente di personalizzare il proprio living.

EN Humidifier

The utmost in comfort is achieved when using the stainless steel dehumidifier. The addition of perfumed essences allows for a personalised touch to your habitat.

FR Humidificateur

Le confort dans la pièce atteint son apogée grâce à un humidificateur avec bac en acier inox. L'ajout d'essences parfumées permet de personnaliser la pièce.

DE Luftbefeuchter

Für noch besseren Komfort im Raum kann ein Luftbefeuchter aus Edelstahl eingesetzt werden. Der Zusatz von Duftessenzen erlaubt eine weitere persönliche Gestaltung des eigenen Wohnraums.

ES Humidificado

El máximo confort en el ambiente se logra con el empleo del humidificador con cuba de acero inoxidable. El añadido de fragancias perfumadas permite personalizar la sala de estar.



OVEN



La gamma di stufe a legna Piazzetta offre anche dei modelli provvisti di un pratico forno per la cottura di pietanze, dotato di termostato, che sfrutta il calore naturale del fuoco a legna.

EN Oven

The range of Piazzetta wood-burning stoves also includes models equipped with a practical oven for cooking food. This is fitted with a thermostat that uses the natural heat of the wood fire.

FR Four

La gamme de poêles à bois Piazzetta comprend aussi des modèles dotés d'un four très pratique équipé d'un thermostat, qui exploite la chaleur naturelle du feu de bois et permet de cuire différents plats.

DE Backofen

Die Piazzetta Holzöfen-Produktreihe bietet auch Modelle mit praktischem Backofen mit integriertem Thermostat zum Zubereiten von Gerichten an, der die natürliche Wärme des Holzofens ausnutzt.

ES Horno

La gama de estufas de leña Piazzetta ofrece además modelos provistos de un práctico horno para la cocción de alimentos, equipado con termostato, que aprovecha el calor natural del fuego de leña.



SAFETY



La sicurezza di un prodotto Piazzetta viene garantita durante tutte le operazioni di gestione e nel funzionamento. La chiusura della porta e la maniglia garantiscono il massimo comfort d'uso.

EN Safety

The safety of Piazzetta products is guaranteed during all control and operating functions. The closure of the door and handle ensure maximum comfort.

FR Sécurité

La sécurité des produits Piazzetta est garantie pendant toutes les opérations de gestion et lors du fonctionnement. La fermeture de la porte et la poignée assurent un confort d'utilisation maximal.

DE Sicherheit

Die Sicherheit eines Piazzetta Produkts ist bei allen Verwaltungsoperationen und während des Betriebs gewährleistet. Der Türverschluss und der Handgriff garantieren maximalen Nutzungskomfort.

ES Seguridad

La seguridad de un producto Piazzetta se garantiza en todas las operaciones de gestión y funcionamiento. El cierre de la puerta y el tirador aseguran la máxima comodidad de uso.



Caratteristiche

EN Characteristics
FR Caractéristiques
DE Eigenschaften
ES Características

 **Calcolato in base alla potenza termica nominale e riferito ad ambienti con un fabbisogno da 0,060 a 0,035 kW per m³.**

EN Calculated on the basis of the rated heat output and referring to environments with a demand from 0.060 to 0.035 kW per m³.

FR Calculé en fonction de la puissance thermique nominale en référence à des pièces dont les besoins vont de 0,060 à 0,035 kW par m³.

DE Berechnet auf Grundlage der Nennwärmeleistung und bezogen auf Räume mit einem Bedarf von 0,060 bis 0,035 kW pro m³.

ES Calculado en función de la potencia térmica nominal y referido a ambientes con una demanda de 0,060 a 0,035 kW por m³.

*	A	B	C
	X cm	Y cm	Z cm

A = Ø Scarico Fumi
B = Uscita canalizzazione
C = Condotta aria comburente

A = Ø Flue outlet
B = Ducting outlet
C = Combustion air conduit

A = Ø Sortie des fumées
B = Sortie canalisation
C = Conduit de l'air comburant

A = Ø Rauchabzug
B = Auslass Kanalsystem
C = Verbrennungsluftführung

A = Ø Salida de humos
B = Salida canalización
C = Conducto aire de combustión

Stile e arredo

BONNY



Energy class		A
Type		SL322-02
Room heating capacity	m ³	150 - 260
Nominal heat output	kW	9,0
Thermal efficiency	%	80,5
Nominal consumption	kg/h	2,7
Weight	kg	164
Dimensions (WxDxH)	cm	81x46x109

MAIN FEATURES



GENERAL CHARACTERISTICS

- Steel firebox
 - Aluker fireplace
 - Cast iron brazier
 - Cast iron door
 - Top flue outlet
 - Air wash
 - Humidifier
 - Removable ash box
 - Orientable front ventilation
- OPTIONAL
- Vacuum

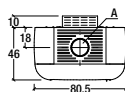
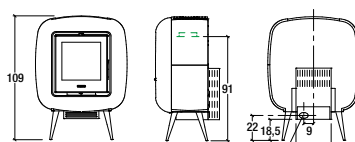

Model: BONNY

COLORI - COLOURS - COULEURS - FARBEN - COLORES



CIRCLE

Hermetic



Energy class		A+
Type		SL300-03
Room heating capacity	m ³	120 - 210
Nominal heat output	kW	7,2
Thermal efficiency	%	85,1
Nominal consumption	kg/h	1,9
Weight	kg	140
Weight with HSS	kg	189
Dimensions (WxDxH)	cm	49x49x122

MAIN FEATURES



GENERAL CHARACTERISTICS

- Steel firebox
 - Majolica cladding
 - Aluker fireplace
 - Cast iron/Skamolex brazier
 - Cast iron door
 - Top flue outlet
 - Rear flue outlet
 - Air wash
 - Tertiary air
 - Humidifier
- OPTIONAL
- Removable ash box
 - Removable steel feet
 - External air kit
 - Vacuum

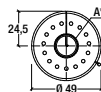
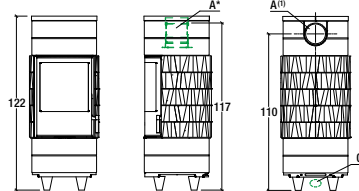

Model: CIRCLE Hermetic

COLORI - COLOURS - COULEURS - FARBEN - COLORES



CIRCLE BCS

Hermetic



Energy class		A+
Type		SL301-03
Room heating capacity	m ³	120 - 210
Nominal heat output	kW	7,2
Thermal efficiency	%	85,3
Nominal consumption	kg/h	1,9
Weight	kg	140
Weight with HSS	kg	189
Dimensions (WxDxH)	cm	49x49x122

MAIN FEATURES



GENERAL CHARACTERISTICS

- Steel firebox
- Majolica cladding
- Aluker fireplace
- Cast iron/Skamolex brazier
- Cast iron door
- Top flue outlet
- Rear flue outlet
- Air wash
- Tertiary air
- Humidifier
- Removable ash box
- Removable steel feet
- OPTIONAL
- External air kit
- Vacuum

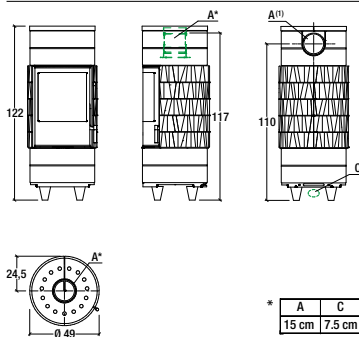

Model: CIRCLE BCS

COLORI - COLOURS - COULEURS - FARBEN - COLORES



p.46

E900 M con forno



Energy class		A
Type		E900
Room heating capacity	m ³	220 - 375
Nominal heat output	kW	13,0
Thermal efficiency	%	79,0
Nominal consumption	kg/h	3,9
Weight	kg	305
Dimensions (WxDxH)	cm	78x63x146
Oven dimens. (WxDxH)	cm	41x40x31

MAIN FEATURES



GENERAL CHARACTERISTICS

- Steel firebox
- Inox steel oven with thermostat
- Cast iron fireplace
- Cast iron brazier
- Cast iron door
- Top flue outlet
- Air wash
- Ash Tray
- Orientable front ventilation
- Removable ash box
- OPTIONAL
- Vacuum

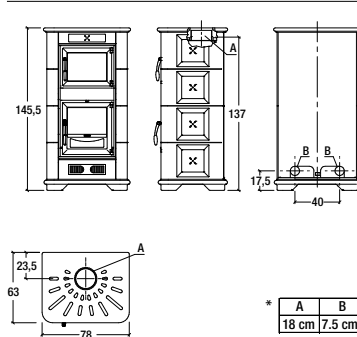

Model: E900 M

COLORI - COLOURS - COULEURS - FARBEN - COLORES



p.128

E911



Energy class		A+
Type		E911
Room heating capacity	m ³	120 - 200
Nominal heat output	kW	7,0
Thermal efficiency	%	84,9
Nominal consumption	kg/h	2,0
Weight	kg	230
Dimensions (WxDxH)	cm	56x47x135
Oven dimens. (WxDxH)	cm	31x34x27

MAIN FEATURES



GENERAL CHARACTERISTICS

- Steel firebox
- Inox steel oven with thermostat
- Aluker fireplace
- Cast iron brazier
- Cast iron door
- Top flue outlet
- Air wash
- Orientable front ventilation
- Removable ash box
- OPTIONAL
- External air kit
- Vacuum

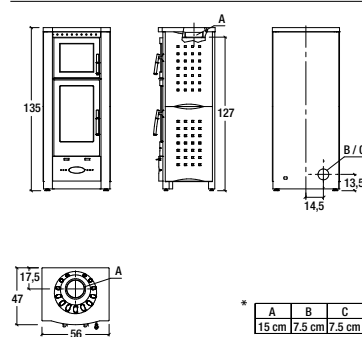

Model: E911

COLORI - COLOURS - COULEURS - FARBEN - COLORES



p.126

E924 Hermetic



Energy class		A+
Type		SL300-03
Room heating capacity	m ³	120 - 210
Nominal heat output	kW	7,2
Thermal efficiency	%	85,1
Nominal consumption	kg/h	1,9
Weight	kg	141
Weight with HSS	kg	190
Dimensions (WxDxH)	cm	46x46x114

MAIN FEATURES



GENERAL CHARACTERISTICS

- Steel firebox
 - Majolica cladding
 - Aluker fireplace
 - Cast iron/Skamolex brazier
 - Steel door
 - Top flue outlet
 - Rear flue outlet
 - Air wash
 - Tertiary air
 - Removable ash box
- OPTIONAL
- Vacuum
 - External air kit
 - Humidifier

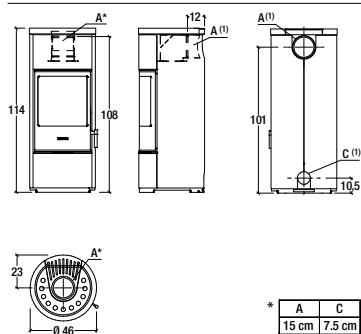

COLORI - COLOURS - COULEURS - FARBEN - COLORES



E924 BCS Hermetic



Energy class		A+
Type		SL301-03
Room heating capacity	m ³	120 - 210
Nominal heat output	kW	7,2
Thermal efficiency	%	85,3
Nominal consumption	kg/h	1,9
Weight	kg	141
Weight with HSS	kg	190
Dimensions (WxDxH)	cm	46x46x114

MAIN FEATURES



GENERAL CHARACTERISTICS

- Steel firebox
 - Majolica cladding
 - Aluker fireplace
 - Cast iron/Skamolex brazier
 - Steel door
 - Top flue outlet
 - Rear flue outlet
 - Air wash
 - Tertiary air
 - Removable ash box
- OPTIONAL
- Vacuum
 - External air kit
 - Humidifier

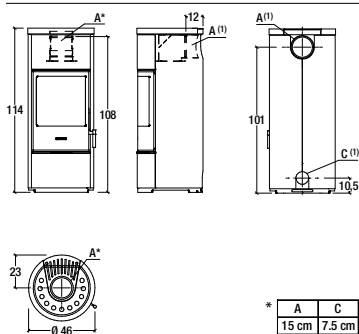

COLORI - COLOURS - COULEURS - FARBEN - COLORES



E924 A Hermetic



Energy class		A+
Type		SL300-03
Room heating capacity	m ³	120 - 210
Nominal heat output	kW	7,2
Thermal efficiency	%	85,1
Nominal consumption	kg/h	1,9
Weight	kg	143
Dimensions (WxDxH)	cm	46x46x124

MAIN FEATURES



GENERAL CHARACTERISTICS

- Steel firebox
 - Majolica cladding
 - Aluker fireplace
 - Cast iron/Skamolex brazier
 - Steel door
 - Top flue outlet
 - Air wash
 - Tertiary air
 - Removable ash box
- OPTIONAL
- Vacuum

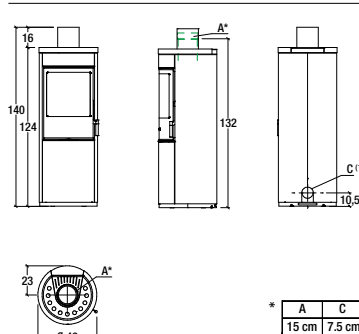

COLORI - COLOURS - COULEURS - FARBEN - COLORES



Stile e arredo

E924 A BCS

Hermetic



Energy class		A+
Type		SL301-03
Room heating capacity	m ³	120 - 210
Nominal heat output	kW	7,2
Thermal efficiency	%	85,3
Nominal consumption	kg/h	1,9
Weight	kg	143
Dimensions (WxDxH)	cm	46x46x124

MAIN FEATURES



GENERAL CHARACTERISTICS

- Steel firebox **OPTIONAL**
- Majolica cladding
- Aluker fireplace
- Cast iron/Skamolex brazier
- Steel door
- Top flue outlet
- Air wash
- Tertiary air
- Removable ash box
- Vacuum
- External air kit

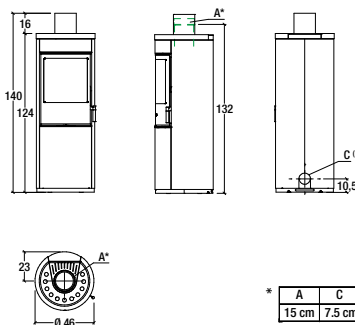

COLORI - COLOURS - COULEURS - FARBEN - COLORES



E924 A-H

Hermetic



Energy class		A+
Type		SL300-03
Room heating capacity	m ³	120 - 210
Nominal heat output	kW	7,2
Thermal efficiency	%	85,1
Nominal consumption	kg/h	1,9
Weight	kg	163
Weight with HSS	kg	277
Dimensions (WxDxH)	cm	46x46x162

MAIN FEATURES



GENERAL CHARACTERISTICS

- Steel firebox **OPTIONAL**
- Majolica cladding
- Aluker fireplace
- Cast iron/Skamolex brazier
- Steel door
- Top flue outlet
- Rear flue outlet
- Air wash
- Tertiary air
- Removable ash box
- Vacuum
- External air kit

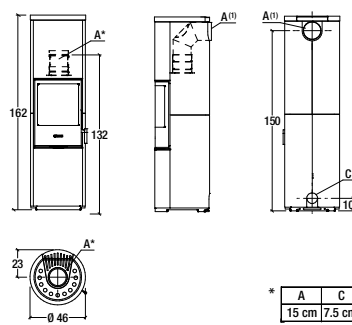

COLORI - COLOURS - COULEURS - FARBEN - COLORES



E924 A-H BCS

Hermetic



Energy class		A+
Type		SL301-03
Room heating capacity	m ³	120 - 210
Nominal heat output	kW	7,2
Thermal efficiency	%	85,3
Nominal consumption	kg/h	1,9
Weight	kg	163
Weight with HSS	kg	277
Dimensions (WxDxH)	cm	46x46x162

MAIN FEATURES



GENERAL CHARACTERISTICS

- Steel firebox **OPTIONAL**
- Majolica cladding
- Aluker fireplace
- Cast iron/Skamolex brazier
- Steel door
- Top flue outlet
- Rear flue outlet
- Air wash
- Tertiary air
- Removable ash box
- Vacuum
- External air kit

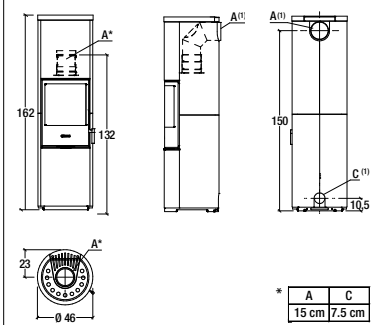

COLORI - COLOURS - COULEURS - FARBEN - COLORES



E924 H

Hermetic



Energy class		A+
Type		SL300-03
Room heating capacity	m ³	120 - 210
Nominal heat output	kW	7,2
Thermal efficiency	%	85,1
Nominal consumption	kg/h	1,9
Weight	kg	151
Weight with HSS	kg	265
Dimensions (WxDxH)	cm	46x46x138

MAIN FEATURES



GENERAL CHARACTERISTICS

- Steel firebox
 - Majolica cladding
 - Aluker fireplace
 - Cast iron/Skamolex brazier
 - Steel door
 - Top flue outlet
 - Rear flue outlet
 - Air wash
 - Tertiary air
 - Removable ash box
- OPTIONAL
- Vacuum
 - External air kit

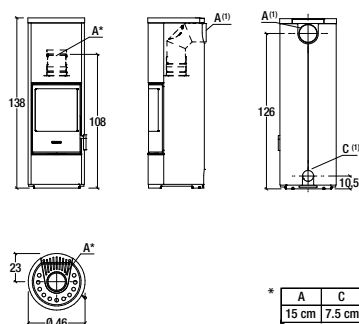

Model: E924-H Hermetic

COLORI - COLOURS - COULEURS - FARBEN - COLORES



E924 H BCS

Hermetic



Energy class		A+
Type		SL301-03
Room heating capacity	m ³	120 - 210
Nominal heat output	kW	7,2
Thermal efficiency	%	85,3
Nominal consumption	kg/h	1,9
Weight	kg	151
Weight with HSS	kg	265
Dimensions (WxDxH)	cm	46x46x138

MAIN FEATURES



GENERAL CHARACTERISTICS

- Steel firebox
 - Majolica cladding
 - Aluker fireplace
 - Cast iron/Skamolex brazier
 - Steel door
 - Top flue outlet
 - Rear flue outlet
 - Air wash
 - Tertiary air
 - Removable ash box
- OPTIONAL
- Vacuum
 - External air kit

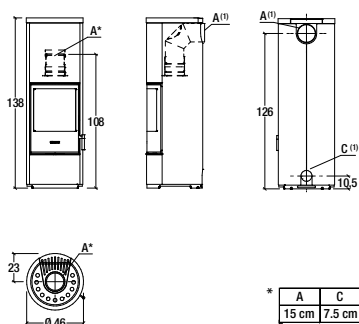

Model: E924-H BCS

COLORI - COLOURS - COULEURS - FARBEN - COLORES



E924 M

Hermetic



Energy class		A+
Type		SL300-03
Room heating capacity	m ³	120 - 210
Nominal heat output	kW	7,2
Thermal efficiency	%	85,1
Nominal consumption	kg/h	1,9
Weight	kg	147
Weight with HSS	kg	196
Dimensions (WxDxH)	cm	52x52x115

MAIN FEATURES



GENERAL CHARACTERISTICS

- Steel firebox
 - Majolica cladding
 - Aluker fireplace
 - Cast iron/Skamolex brazier
 - Steel door
 - Top flue outlet
 - Rear flue outlet
 - Air wash
 - Tertiary air
 - Removable ash box
- OPTIONAL
- Vacuum
 - External air kit
 - Humidifier

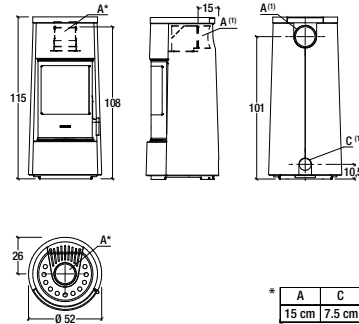

Model: E924 M Hermetic

COLORI - COLOURS - COULEURS - FARBEN - COLORES



Stile e arredo

E924 M BCS

Hermetic



Energy class		A+
Type		SL301-03
Room heating capacity	m ³	120 - 210
Nominal heat output	kW	7,2
Thermal efficiency	%	85,3
Nominal consumption	kg/h	1,9
Weight	kg	147
Weight with HSS	kg	196
Dimensions (WxDxH)	cm	52x52x115

MAIN FEATURES



GENERAL CHARACTERISTICS

- Steel firebox
 - Majolica cladding
 - Aluker fireplace
 - Cast iron/Skamolex brazier
 - Steel door
 - Top flue outlet
 - Rear flue outlet
 - Air wash
 - Tertiary air
 - Removable ash box
- OPTIONAL
- Vacuum
 - External air kit
 - Humidifier

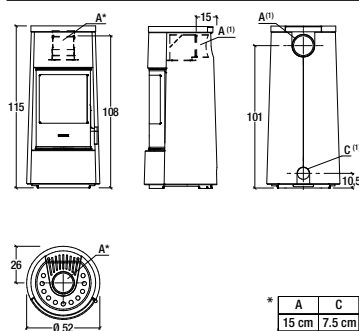

Model: E924 M BCS

COLORI - COLOURS - COULEURS - FARBEN - COLORES

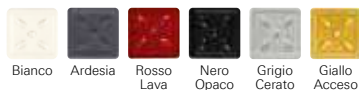

E928



Energy class		A+
Type		SL31-01
Room heating capacity	m ³	185 - 315
Nominal heat output	kW	11,0
Thermal efficiency	%	86,0
Nominal consumption	kg/h	2,9
Weight	kg	240
Weight with HSS	kg	285
Dimensions (WxDxH)	cm	57x45x127

MAIN FEATURES



GENERAL CHARACTERISTICS

- Steel firebox
 - Majolica cladding
 - Aluker fireplace
 - Cast iron brazier
 - Cast iron door
 - Top flue outlet
 - Rear flue outlet
 - Air wash
 - Tertiary air
 - Orientable front ventilation
- OPTIONAL
- Humidifier
 - Removable ash box
 - External air kit
 - Vacuum

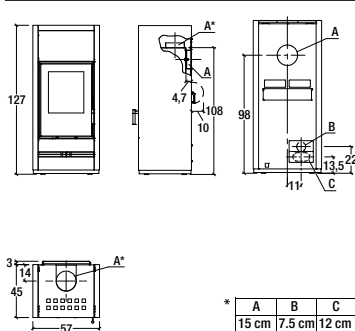

Model: E928

COLORI - COLOURS - COULEURS - FARBEN - COLORES



E928 BCS

Hermetic



Energy class		A+
Type		SL32-01
Room heating capacity	m ³	185 - 320
Nominal heat output	kW	11,1
Thermal efficiency	%	86,6
Nominal consumption	kg/h	2,9
Weight	kg	245
Weight with HSS	kg	290
Dimensions (WxDxH)	cm	57x45x127

MAIN FEATURES



GENERAL CHARACTERISTICS

- Steel firebox
 - Majolica cladding
 - Aluker fireplace
 - Cast iron brazier
 - Cast iron door
 - Top flue outlet
 - Rear flue outlet
 - Air wash
 - Tertiary air
 - Orientable front ventilation
- OPTIONAL
- Humidifier
 - Removable ash box
 - Vacuum

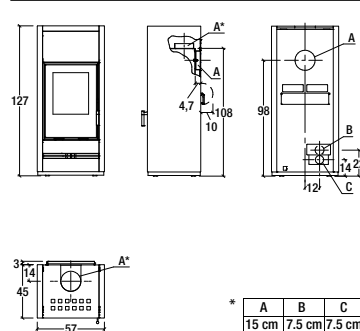

Model: E928 BCS

COLORI - COLOURS - COULEURS - FARBEN - COLORES



E928 Steel



Energy class		A+
Type		SL31-01
Room heating capacity	m ³	185 - 315
Nominal heat output	kW	11,0
Thermal efficiency	%	86,0
Nominal consumption	kg/h	2,9
Weight	kg	195
Dimensions (WxDxH)	cm	60x47x114

MAIN FEATURES



GENERAL CHARACTERISTICS

- Steel firebox
- Steel cladding
- Cast iron brazier
- Cast iron door
- Top flue outlet
- Rear flue outlet
- Air wash
- Tertiary air
- Orientable front ventilation
- Humidifier
- Removable ash box
- OPTIONAL
 - External air kit
 - Vacuum

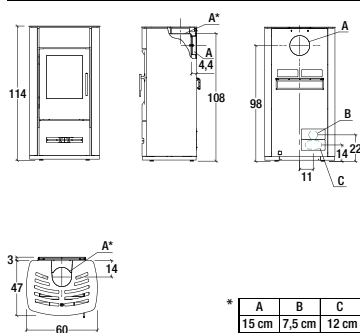

Model: E928 ST

COLORI - COLOURS - COULEURS - FARBEN - COLORES

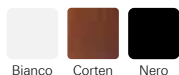

Bianco Corten Nero

E928 A



Energy class		A+
Type		SL31-01
Room heating capacity	m ³	185 - 315
Nominal heat output	kW	11,0
Thermal efficiency	%	86,0
Nominal consumption	kg/h	2,9
Weight	kg	255
Dimensions (WxDxH)	cm	57x45x141

MAIN FEATURES

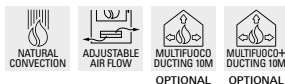

GENERAL CHARACTERISTICS

- Steel firebox
- Majolica cladding
- Aluker fireplace
- Cast iron brazier
- Cast iron door
- Top flue outlet
- Rear flue outlet
- Air wash
- Tertiary air
- Humidifier
- Removable ash box
- OPTIONAL
 - External air kit
 - Vacuum

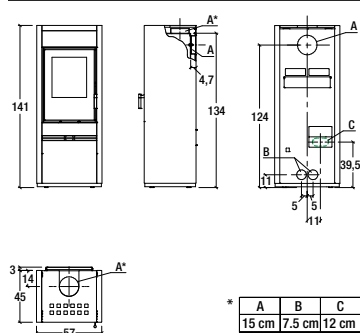

Model: E928 A

COLORI - COLOURS - COULEURS - FARBEN - COLORES

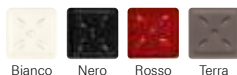

Bianco Nero Opaco Rosso Lava Terra Cotta

E928 A BCS

Hermetic



Energy class		A+
Type		SL32-01
Room heating capacity	m ³	185 - 320
Nominal heat output	kW	11,1
Thermal efficiency	%	86,6
Nominal consumption	kg/h	2,9
Weight	kg	260
Dimensions (WxDxH)	cm	57x45x141

MAIN FEATURES



GENERAL CHARACTERISTICS

- Steel firebox
- Majolica cladding
- Aluker fireplace
- Cast iron brazier
- Cast iron door
- Top flue outlet
- Rear flue outlet
- Air wash
- Tertiary air
- Humidifier
- Removable ash box
- OPTIONAL
 - Vacuum

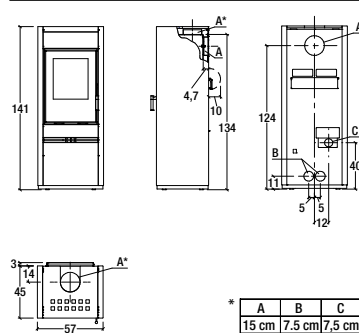

Model: E928 A BCS

COLORI - COLOURS - COULEURS - FARBEN - COLORES



Bianco Nero Opaco Rosso Lava Terra Cotta

E928 C



Energy class		A+
Type		SL31-01
Room heating capacity	m ³	185 - 315
Nominal heat output	kW	11,0
Thermal efficiency	%	86,0
Nominal consumption	kg/h	2,9
Weight	kg	260
Weight with HSS	kg	320
Dimensions (WxDxH)	cm	65x48x144

MAIN FEATURES



GENERAL CHARACTERISTICS

- Steel firebox **OPTIONAL**
- Majolica cladding
- Aluker fireplace
- Cast iron brazier
- Cast iron door
- Top flue outlet
- Rear flue outlet
- Air wash
- Tertiary air
- Humidifier
- Removable ash box
- External air kit
- Vacuum

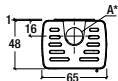
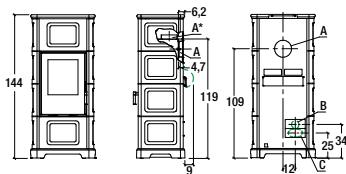

A	B	C
15 cm	7,5 cm	12 cm

Model: E928 C

COLORI - COLOURS - COULEURS - FARBEN - COLORES



E928 C



Energy class		A+
Type		SL31-01
Room heating capacity	m ³	185 - 315
Nominal heat output	kW	11,0
Thermal efficiency	%	86,0
Nominal consumption	kg/h	2,9
Weight	kg	260
Weight with HSS	kg	320
Dimensions (WxDxH)	cm	65x48x144

MAIN FEATURES

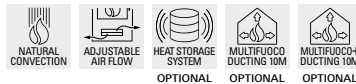

GENERAL CHARACTERISTICS

- Steel firebox **OPTIONAL**
- Majolica cladding
- Aluker fireplace
- Cast iron brazier
- Cast iron door
- Top flue outlet
- Rear flue outlet
- Air wash
- Tertiary air
- Humidifier
- Removable ash box
- External air kit
- Vacuum

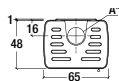
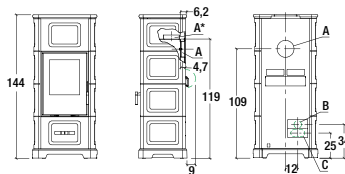

A	B	C
15 cm	7,5 cm	12 cm

Model: E928 C

COLORI - COLOURS - COULEURS - FARBEN - COLORES



E928 C BCS

Hermetic



Energy class		A+
Type		SL32-01
Room heating capacity	m ³	185 - 320
Nominal heat output	kW	11,1
Thermal efficiency	%	86,6
Nominal consumption	kg/h	2,9
Weight	kg	265
Weight with HSS	kg	325
Dimensions (WxDxH)	cm	65x48x144

MAIN FEATURES



GENERAL CHARACTERISTICS

- Steel firebox **OPTIONAL**
- Majolica cladding
- Aluker fireplace
- Cast iron brazier
- Cast iron door
- Top flue outlet
- Rear flue outlet
- Air wash
- Tertiary air
- Humidifier
- Removable ash box
- Vacuum

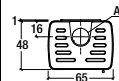
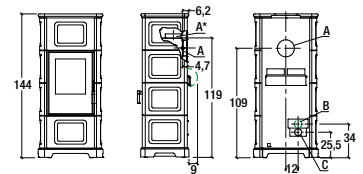

A	B	C
15 cm	7,5 cm	7,5 cm

Model: E928 C BCS

COLORI - COLOURS - COULEURS - FARBEN - COLORES



E928 C BCS

Hermetic



Energy class		A+
Type		SL32-01
Room heating capacity	m ³	185 - 320
Nominal heat output	kW	11,1
Thermal efficiency	%	86,6
Nominal consumption	kg/h	2,9
Weight	kg	265
Weight with HSS	kg	325
Dimensions (WxDxH)	cm	65x48x144

MAIN FEATURES



GENERAL CHARACTERISTICS

- Steel firebox
 - Majolica cladding
 - Aluker fireplace
 - Cast iron brazier
 - Cast iron door
 - Top flue outlet
 - Rear flue outlet
 - Air wash
 - Tertiary air
 - Orientable front ventilation
 - Humidifier
 - Removable ash box
- OPTIONAL
- Vacuum

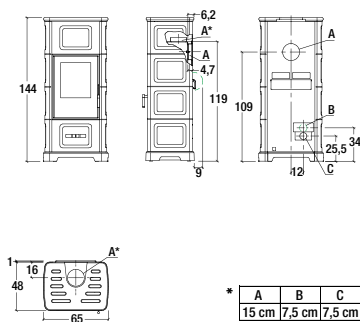

Model: E928 C BCS

COLORI - COLOURS - COULEURS - FARBEN - COLORES



E928 C-H



Energy class		A+
Type		SL31-01
Room heating capacity	m ³	185 - 315
Nominal heat output	kW	11,0
Thermal efficiency	%	86,0
Nominal consumption	kg/h	2,9
Weight	kg	310
Weight with HSS	kg	610
Dimensions (WxDxH)	cm	65x48x209

MAIN FEATURES



GENERAL CHARACTERISTICS

- Steel firebox
- Majolica cladding
- Aluker fireplace
- Cast iron brazier
- Cast iron door
- Top flue outlet
- Rear flue outlet
- Air wash
- Tertiary air
- Humidifier
- Removable ash box
- OPTIONAL
- External air kit
- Vacuum

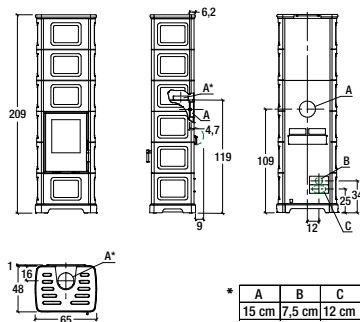

Model: E928 C-H

COLORI - COLOURS - COULEURS - FARBEN - COLORES



E928 C-H



Energy class		A+
Type		SL31-01
Room heating capacity	m ³	185 - 315
Nominal heat output	kW	11,0
Thermal efficiency	%	86,0
Nominal consumption	kg/h	2,9
Weight	kg	310
Weight with HSS	kg	610
Dimensions (WxDxH)	cm	65x48x209

MAIN FEATURES

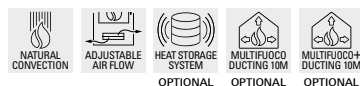

GENERAL CHARACTERISTICS

- Steel firebox
- Majolica cladding
- Aluker fireplace
- Cast iron brazier
- Cast iron door
- Top flue outlet
- Rear flue outlet
- Air wash
- Tertiary air
- Humidifier
- Removable ash box
- OPTIONAL
- External air kit
- Vacuum

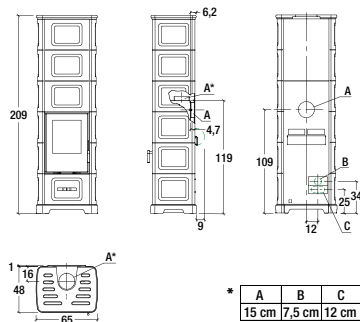

Model: E928 C-H

COLORI - COLOURS - COULEURS - FARBEN - COLORES



Stile e arredo

E928 C-H BCS

Hermetic



Energy class		A+
Type		SL32-01
Room heating capacity	m ³	185 - 320
Nominal heat output	kW	11,1
Thermal efficiency	%	86,6
Nominal consumption	kg/h	2,9
Weight	kg	315
Weight with HSS	kg	615
Dimensions (WxDxH)	cm	65x48x209

MAIN FEATURES

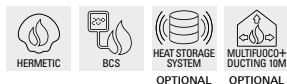

GENERAL CHARACTERISTICS

- Natural convection
- Steel firebox
- Majolica cladding
- Aluker fireplace
- Cast iron brazier
- Cast iron door
- Top flue outlet
- Rear flue outlet
- Air wash
- Tertiary air
- Humidifier
- Removable ash box
- OPTIONAL
- Vacuum

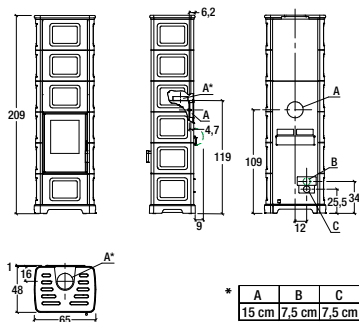

Model: E928 C-H BCS

COLORI - COLOURS - COULEURS - FARBEN - COLORES



E928 C-H BCS

Hermetic



Energy class		A+
Type		SL32-01
Room heating capacity	m ³	185 - 320
Nominal heat output	kW	11,1
Thermal efficiency	%	86,6
Nominal consumption	kg/h	2,9
Weight	kg	315
Weight with HSS	kg	615
Dimensions (WxDxH)	cm	65x48x209

MAIN FEATURES



GENERAL CHARACTERISTICS

- Natural convection
- Steel firebox
- Majolica cladding
- Aluker fireplace
- Cast iron brazier
- Cast iron door
- Top flue outlet
- Rear flue outlet
- Air wash
- Tertiary air
- Humidifier
- Removable ash box
- OPTIONAL
- Vacuum

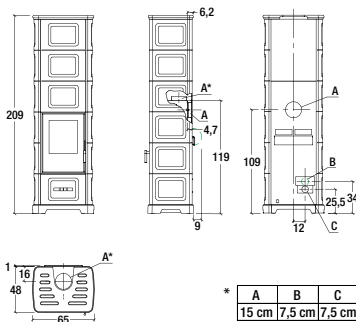

Model: E928 C-H BCS

COLORI - COLOURS - COULEURS - FARBEN - COLORES



E928 C-M



Energy class		A+
Type		SL31-01
Room heating capacity	m ³	185 - 315
Nominal heat output	kW	11,0
Thermal efficiency	%	86,0
Nominal consumption	kg/h	2,9
Weight	kg	285
Weight with HSS	kg	475
Dimensions (WxDxH)	cm	65x48x176

MAIN FEATURES



GENERAL CHARACTERISTICS

- Natural convection
- Steel firebox
- Aluker fireplace
- Cast iron brazier
- Cast iron door
- Top flue outlet
- Rear flue outlet
- Air wash
- Tertiary air
- Humidifier
- Removable ash box
- OPTIONAL
- External air kit
- Vacuum

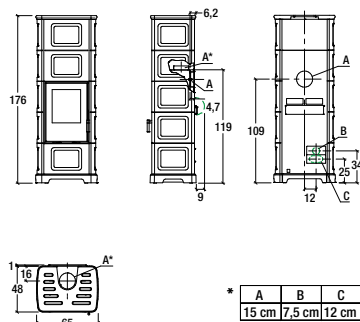

Model: E928 C-M

COLORI - COLOURS - COULEURS - FARBEN - COLORES



E928 C-M



Energy class		A+
Type		SL31-01
Room heating capacity	m ³	185 - 315
Nominal heat output	kW	11,0
Thermal efficiency	%	86,0
Nominal consumption	kg/h	2,9
Weight	kg	285
Weight with HSS	kg	475
Dimensions (WxDxH)	cm	65x48x176

MAIN FEATURES

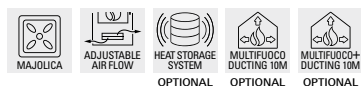

GENERAL CHARACTERISTICS

- Natural convection **OPTIONAL**
- Steel firebox
- Aluker fireplace
- Cast iron brazier
- Cast iron door
- Top flue outlet
- Rear flue outlet
- Air wash
- Tertiary air
- Humidifier
- Removable ash box
- External air kit
- Vacuum

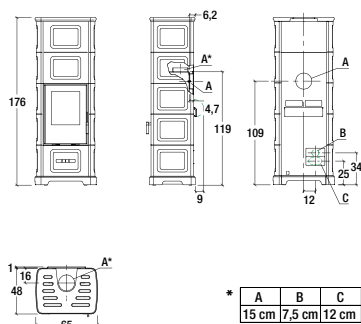

Model: E928 C-M

COLORI - COLOURS - COULEURS - FARBEN - COLORES



E928 C-M BCS

Hermetic



Energy class		A+
Type		SL32-01
Room heating capacity	m ³	185 - 320
Nominal heat output	kW	11,1
Thermal efficiency	%	86,6
Nominal consumption	kg/h	2,9
Weight	kg	290
Weight with HSS	kg	480
Dimensions (WxDxH)	cm	65x48x176

MAIN FEATURES



GENERAL CHARACTERISTICS

- Natural convection **OPTIONAL**
- Steel firebox
- Aluker fireplace
- Cast iron brazier
- Cast iron door
- Top flue outlet
- Rear flue outlet
- Air wash
- Tertiary air
- Humidifier
- Removable ash box
- Vacuum

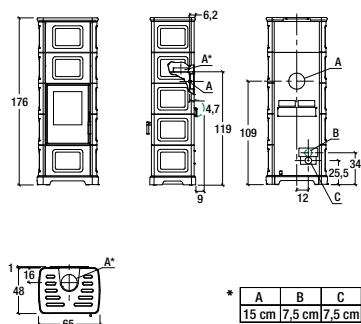

Model: E928 C-M BCS

COLORI - COLOURS - COULEURS - FARBEN - COLORES



E928 C-M BCS

Hermetic



Energy class		A+
Type		SL32-01
Room heating capacity	m ³	185 - 320
Nominal heat output	kW	11,1
Thermal efficiency	%	86,6
Nominal consumption	kg/h	2,9
Weight	kg	290
Weight with HSS	kg	480
Dimensions (WxDxH)	cm	65x48x176

MAIN FEATURES



GENERAL CHARACTERISTICS

- Natural convection
- Steel firebox
- Aluker fireplace
- Cast iron brazier
- Cast iron door
- Top flue outlet
- Rear flue outlet
- Air wash
- Tertiary air
- Orientable front ventilation
- Humidifier
- Removable ash box
- Vacuum

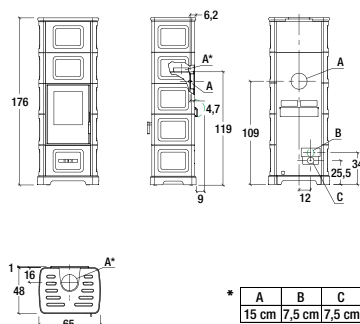

Model: E928 C-M BCS

COLORI - COLOURS - COULEURS - FARBEN - COLORES



E928 H



Energy class		A+
Type		SL31-01
Room heating capacity	m ³	185 - 315
Nominal heat output	kW	11,0
Thermal efficiency	%	86,0
Nominal consumption	kg/h	2,9
Weight	kg	280
Weight with HSS	kg	530
Dimensions (WxDxH)	cm	57x45x187

MAIN FEATURES



GENERAL CHARACTERISTICS

- Natural convection
 - Steel firebox
 - Aluker fireplace
 - Cast iron brazier
 - Cast iron door
 - Top flue outlet
 - Rear flue outlet
 - Air wash
 - Tertiary air
 - Orientable front ventilation
- Humidifier
 - Removable ash box
- OPTIONAL
- External air kit
 - Vacuum

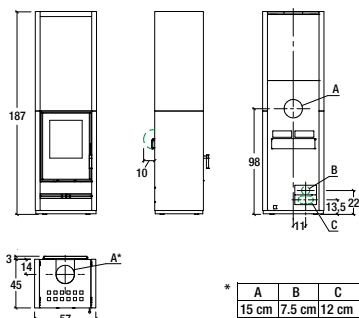

COLORI - COLOURS - COULEURS - FARBEN - COLORES

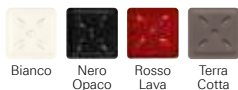

E928 H BCS

Hermetic



Energy class		A+
Type		SL32-01
Room heating capacity	m ³	185 - 320
Nominal heat output	kW	11,1
Thermal efficiency	%	86,6
Nominal consumption	kg/h	2,9
Weight	kg	285
Weight with HSS	kg	535
Dimensions (WxDxH)	cm	57x45x187

MAIN FEATURES



GENERAL CHARACTERISTICS

- Natural convection
 - Steel firebox
 - Aluker fireplace
 - Cast iron brazier
 - Cast iron door
 - Top flue outlet
 - Rear flue outlet
 - Air wash
 - Tertiary air
 - Orientable front ventilation
- Humidifier
 - Removable ash box
- OPTIONAL
- Vacuum

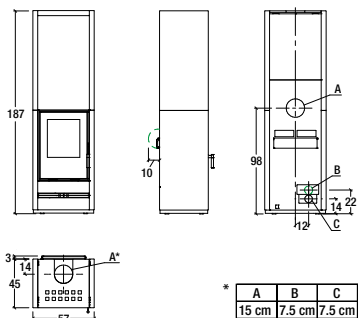

COLORI - COLOURS - COULEURS - FARBEN - COLORES

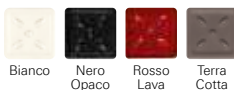

E928 M



Energy class		A+
Type		SL31-01
Room heating capacity	m ³	185 - 315
Nominal heat output	kW	11,0
Thermal efficiency	%	86,0
Nominal consumption	kg/h	2,9
Weight	kg	250
Weight with HSS	kg	340
Dimensions (WxDxH)	cm	57x45x141

MAIN FEATURES



GENERAL CHARACTERISTICS

- Natural convection
 - Steel firebox
 - Aluker fireplace
 - Cast iron brazier
 - Cast iron door
 - Top flue outlet
 - Rear flue outlet
 - Air wash
 - Tertiary air
 - Orientable front ventilation
- Humidifier
 - Removable ash box
- OPTIONAL
- External air kit
 - Vacuum

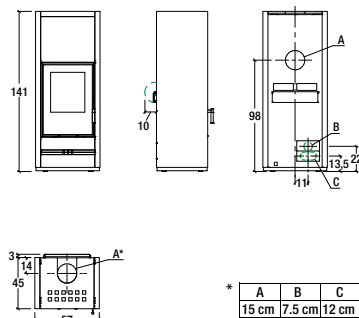

COLORI - COLOURS - COULEURS - FARBEN - COLORES



E928 M BCS

Hermetic



Energy class		A+
Type		SL32-01
Room heating capacity	m ³	185 - 320
Nominal heat output	kW	11,1
Thermal efficiency	%	86,6
Nominal consumption	kg/h	2,9
Weight	kg	255
Weight with HSS	kg	345
Dimensions (WxDxH)	cm	57x45x141

MAIN FEATURES



GENERAL CHARACTERISTICS

- Natural convection
 - Steel firebox
 - Aluker fireplace
 - Cast iron brazier
 - Cast iron door
 - Top flue outlet
 - Rear flue outlet
 - Air wash
 - Tertiary air
 - Orientable front ventilation
 - Humidifier
 - Removable ash box
- OPTIONAL
- Vacuum

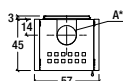

Model: E928-M BCS

COLORI - COLOURS - COULEURS - FARBEN - COLORES



Bianco
Nero Opaco
Rosso Lava
Terra Cotta

p.86

E928 R



Energy class		A+
Type		SL31-01
Room heating capacity	m ³	185 - 315
Nominal heat output	kW	11,0
Thermal efficiency	%	86,0
Nominal consumption	kg/h	2,9
Weight	kg	228
Dimensions (WxDxH)	cm	65x49x117

MAIN FEATURES



GENERAL CHARACTERISTICS

- Steel firebox
 - Aluker fireplace
 - Cast iron brazier
 - Cast iron door
 - Top flue outlet
 - Rear flue outlet
 - Air wash
 - Tertiary air
 - Removable ash box
 - Orientable front ventilation
 - Humidifier
 - Vacuum
- OPTIONAL

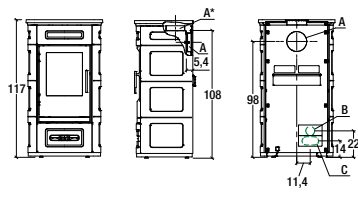

Model: E928 R

COLORI - COLOURS - COULEURS - FARBEN - COLORES



Bianco
Bianco Grigio
Canapa
Verde Mirto
Nero Opaco
Rosso Lava

p.74

E928 S



Energy class		A+
Type		SL31-01
Room heating capacity	m ³	185 - 315
Nominal heat output	kW	11,0
Thermal efficiency	%	86,0
Nominal consumption	kg/h	2,9
Weight	kg	260
Dimensions (WxDxH)	cm	57x45x141

MAIN FEATURES



GENERAL CHARACTERISTICS

- Natural convection
 - Steel firebox
 - Aluker fireplace
 - Cast iron brazier
 - Cast iron door
 - Top flue outlet
 - Rear flue outlet
 - Air wash
 - Tertiary air
 - Removable ash box
 - Humidifier
 - Orientable front ventilation
 - External air kit
 - Vacuum
- OPTIONAL

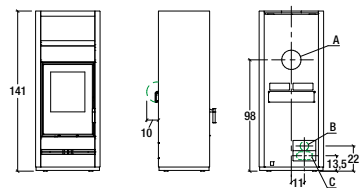

Model: E928 S

COLORI - COLOURS - COULEURS - FARBEN - COLORES



Bianco
Nero Opaco
Rosso Lava
Terra Cotta

p.92

Stile e arredo

E928 S BCS

Hermetic



Energy class		A+
Type		SL32-01
Room heating capacity	m ³	185 - 320
Nominal heat output	kW	11,1
Thermal efficiency	%	86,6
Nominal consumption	kg/h	2,9
Weight	kg	265
Dimensions (WxDxH)	cm	57x45x141

MAIN FEATURES



GENERAL CHARACTERISTICS

- Natural convection
 - Steel firebox
 - Aluker fireplace
 - Cast iron brazier
 - Cast iron door
 - Top flue outlet
 - Rear flue outlet
 - Air wash
 - Tertiary air
 - Humidifier
 - Removable ash box
- OPTIONAL
- Orientable front ventilation
 - Vacuum

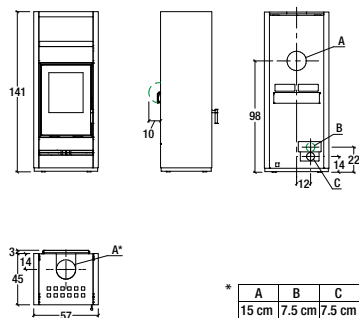

COLORI - COLOURS - COULEURS - FARBEN - COLORES

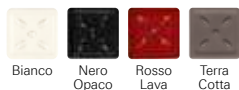

E929 C

Hermetic



Energy class		A+
Type		SL310-04
Room heating capacity	m ³	135 - 230
Nominal heat output	kW	7,9
Thermal efficiency	%	85,7
Nominal consumption	kg/h	2,2
Weight	kg	183
Weight with HSS	kg	233
Dimensions (WxDxH)	cm	59x59x141

MAIN FEATURES



GENERAL CHARACTERISTICS

- Natural convection
 - Steel firebox
 - Aluker fireplace
 - Cast iron/Skamolex brazier
 - Steel door
 - Top flue outlet
 - Air wash
 - Tertiary air
 - Removable ash box
- OPTIONAL
- Vacuum
 - External air kit

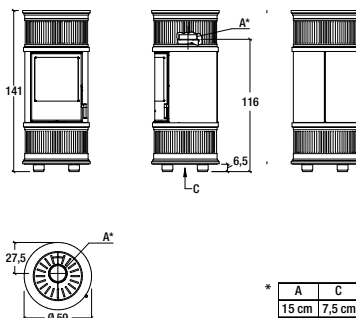

COLORI - COLOURS - COULEURS - FARBEN - COLORES



p.92

E929 C

Hermetic



Energy class		A+
Type		SL310-04
Room heating capacity	m ³	135 - 230
Nominal heat output	kW	7,9
Thermal efficiency	%	85,7
Nominal consumption	kg/h	2,2
Weight	kg	183
Weight with HSS	kg	233
Dimensions (WxDxH)	cm	59x59x141

MAIN FEATURES



GENERAL CHARACTERISTICS

- Natural convection
 - Steel firebox
 - Aluker fireplace
 - Cast iron/Skamolex brazier
 - Steel door
 - Top flue outlet
 - Air wash
 - Tertiary air
 - Orientable front ventilation
- OPTIONAL
- Removable ash box
 - Vacuum
 - External air kit

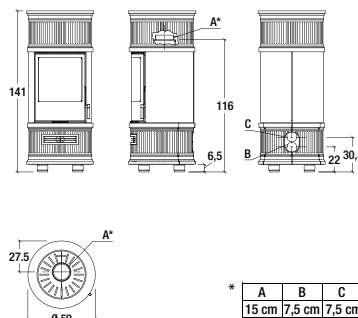

COLORI - COLOURS - COULEURS - FARBEN - COLORES



p.70

E929 C BCS

Hermetic



Energy class		A+
Type		SL311-04
Room heating capacity	m ³	130 - 225
Nominal heat output	kW	7,8
Thermal efficiency	%	87,6
Nominal consumption	kg/h	2,1
Weight	kg	183
Weight with HSS	kg	233
Dimensions (WxDxH)	cm	59x59x141

MAIN FEATURES



GENERAL CHARACTERISTICS

- Natural convection **OPTIONAL**
- Steel firebox
- Aluker fireplace
- Cast iron/Skamolex brazier
- Steel door
- Top flue outlet
- Air wash
- Tertiary air
- Removable ash box
- Vacuum
- External air kit

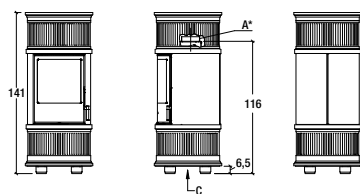

Model: E929 C BCS

COLORI - COLOURS - COULEURS - FARBEN - COLORES



Bianco Bordeaux Canapa



/Terra Bruna /Blu Verdemare

p.70

E929 C BCS

Hermetic



Energy class		A+
Type		SL311-04
Room heating capacity	m ³	130 - 225
Nominal heat output	kW	7,8
Thermal efficiency	%	87,6
Nominal consumption	kg/h	2,1
Weight	kg	183
Weight with HSS	kg	233
Dimensions (WxDxH)	cm	59x59x141

MAIN FEATURES



GENERAL CHARACTERISTICS

- Natural convection
- Steel firebox
- Aluker fireplace
- Cast iron/Skamolex brazier
- Steel door
- Top flue outlet
- Air wash
- Tertiary air
- Orientable front ventilation
- Removable ash box
- Vacuum
- External air kit

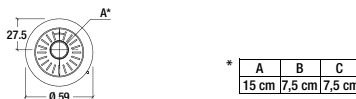
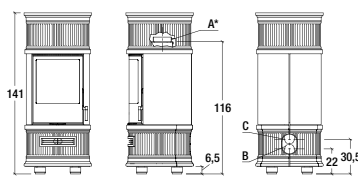

Model: E929 C BCS

COLORI - COLOURS - COULEURS - FARBEN - COLORES



Bianco Bordeaux Canapa



/Terra Bruna /Blu Verdemare

p.70

E929 C-H

Hermetic



Energy class		A+
Type		SL310-04
Room heating capacity	m ³	135 - 230
Nominal heat output	kW	7,9
Thermal efficiency	%	85,7
Nominal consumption	kg/h	2,2
Weight	kg	206
Weight with HSS	kg	422
Dimensions (WxDxH)	cm	59x59x191

MAIN FEATURES



GENERAL CHARACTERISTICS

- Natural convection **OPTIONAL**
- Steel firebox
- Aluker fireplace
- Cast iron/Skamolex brazier
- Steel door
- Top flue outlet
- Air wash
- Tertiary air
- Removable ash box
- Vacuum
- External air kit

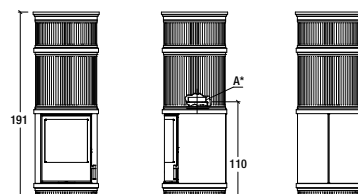

Model: E929 C-H Hermetic

COLORI - COLOURS - COULEURS - FARBEN - COLORES



Bianco Bordeaux Canapa



/Terra Bruna /Blu Verdemare

p.72

Stile e arredo

E929 C-H

Hermetic



Energy class		A+
Type		SL310-04
Room heating capacity	m ³	135 - 230
Nominal heat output	kW	7,9
Thermal efficiency	%	85,7
Nominal consumption	kg/h	2,2
Weight	kg	206
Weight with HSS	kg	422
Dimensions (WxDxH)	cm	59x59x191

MAIN FEATURES



GENERAL CHARACTERISTICS

- Natural convection
- Steel firebox
- Aluker fireplace
- Cast iron/Skamolex brazier
- Steel door
- Top flue outlet
- Air wash
- Tertiary air
- Orientable front ventilation
- Removable ash box
- Vacuum
- External air kit

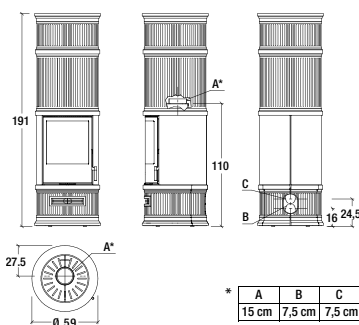

Model: E929 C-H Hermetic

COLORI - COLOURS - COULEURS - FARBEN - COLORES



Bianco Bordeaux Canapa



/Terra Bruna /Blu Verdemare

p.72

E929 C-H BCS

Hermetic



Energy class		A+
Type		SL311-04
Room heating capacity	m ³	130 - 225
Nominal heat output	kW	7,8
Thermal efficiency	%	87,6
Nominal consumption	kg/h	2,1
Weight	kg	206
Weight with HSS	kg	422
Dimensions (WxDxH)	cm	59x59x191

MAIN FEATURES



GENERAL CHARACTERISTICS

- Natural convection
- Steel firebox
- Aluker fireplace
- Cast iron/Skamolex brazier
- Steel door
- Top flue outlet
- Air wash
- Tertiary air
- Removable ash box
- Vacuum
- External air kit

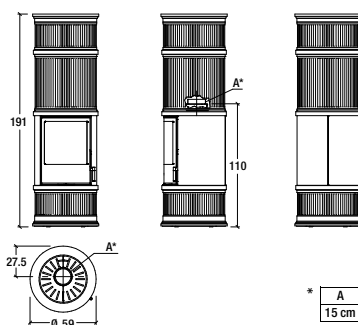

Model: E929 C-H BCS

COLORI - COLOURS - COULEURS - FARBEN - COLORES



Bianco Bordeaux Canapa



/Terra Bruna /Blu Verdemare

p.72

E929 C-H BCS

Hermetic



Energy class		A+
Type		SL311-04
Room heating capacity	m ³	130 - 225
Nominal heat output	kW	7,8
Thermal efficiency	%	87,6
Nominal consumption	kg/h	2,1
Weight	kg	206
Weight with HSS	kg	422
Dimensions (WxDxH)	cm	59x59x191

MAIN FEATURES



GENERAL CHARACTERISTICS

- Natural convection
- Steel firebox
- Aluker fireplace
- Cast iron/Skamolex brazier
- Steel door
- Top flue outlet
- Air wash
- Tertiary air
- Orientable front ventilation
- Removable ash box
- Vacuum
- External air kit

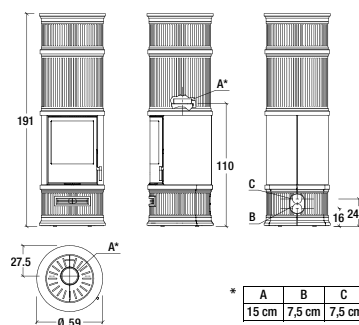

Model: E929 C-H BCS

COLORI - COLOURS - COULEURS - FARBEN - COLORES



Bianco Bordeaux Canapa

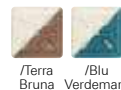

/Terra Bruna /Blu Verdemare

p.72

E929 D

Hermetic



Energy class		A+
Type		SL310-04
Room heating capacity	m ³	135 - 230
Nominal heat output	kW	7,9
Thermal efficiency	%	85,7
Nominal consumption	kg/h	2,2
Weight	kg	164
Dimensions (WxDxH)	cm	55x55x115

MAIN FEATURES



GENERAL CHARACTERISTICS

- Natural convection
- Steel firebox
- Aluker fireplace
- Cast iron/Skamolex brazier
- Steel door
- Top flue outlet
- Rear flue outlet
- Humidifier
- Air wash
- Tertiary air
- Removable ash box
- Orientable front ventilation
- OPTIONAL
- Vacuum

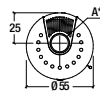
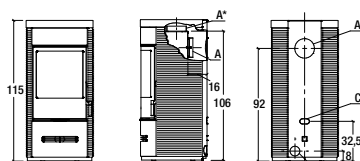

Model: E929 D Hermetic

COLORI - COLOURS - COULEURS - FARBEN - COLORES



E929 D BCS

Hermetic



Energy class		A+
Type		SL311-04
Room heating capacity	m ³	130 - 225
Nominal heat output	kW	7,8
Thermal efficiency	%	87,6
Nominal consumption	kg/h	2,1
Weight	kg	164
Dimensions (WxDxH)	cm	55x55x115

MAIN FEATURES



GENERAL CHARACTERISTICS

- Natural convection
- Steel firebox
- Aluker fireplace
- Cast iron/Skamolex brazier
- Steel door
- Top flue outlet
- Rear flue outlet
- Humidifier
- Air wash
- Tertiary air
- Removable ash box
- Orientable front ventilation
- OPTIONAL
- Vacuum

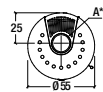
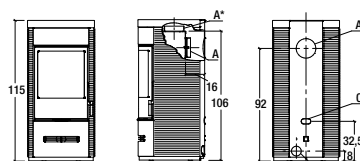

Model: E929 D BCS

COLORI - COLOURS - COULEURS - FARBEN - COLORES



E929 D-H

Hermetic



Energy class		A+
Type		SL310-04
Room heating capacity	m ³	135 - 230
Nominal heat output	kW	7,9
Thermal efficiency	%	85,7
Nominal consumption	kg/h	2,2
Weight	kg	194
Weight with HSS	kg	360
Dimensions (WxDxH)	cm	55x55x170

MAIN FEATURES



GENERAL CHARACTERISTICS

- Natural convection
- Steel firebox
- Aluker fireplace
- Cast iron/Skamolex brazier
- Steel door
- Top flue outlet
- Rear flue outlet
- Humidifier
- Air wash
- Tertiary air
- Removable ash box
- Orientable front ventilation
- OPTIONAL
- Vacuum

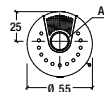
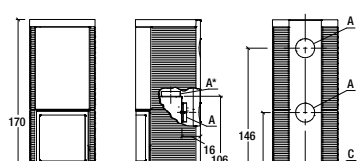

Model: E929 D-H Hermetic

COLORI - COLOURS - COULEURS - FARBEN - COLORES



Stile e arredo

E929 D-H BCS

Hermetic



Energy class		A+
Type		SL311-04
Room heating capacity	m ³	130 - 225
Nominal heat output	kW	7,8
Thermal efficiency	%	87,6
Nominal consumption	kg/h	2,1
Weight	kg	194
Weight with HSS	kg	360
Dimensions (WxDxH)	cm	55x55x170

MAIN FEATURES



GENERAL CHARACTERISTICS

- Natural convection
- Steel firebox
- Aluker fireplace
- Cast iron/Skamolex brazier
- Steel door
- Top flue outlet
- Rear flue outlet
- Humidifier
- Air wash
- Tertiary air
- Removable ash box
- Orientable front ventilation
- OPTIONAL
- Vacuum

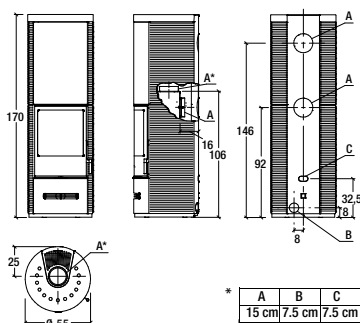

Model: E929 D-H BCS

COLORI - COLOURS - COULEURS - FARBEN - COLORES

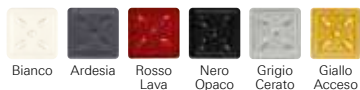

E929 M

Hermetic



Energy class		A+
Type		SL310-04
Room heating capacity	m ³	135 - 230
Nominal heat output	kW	7,9
Thermal efficiency	%	85,7
Nominal consumption	kg/h	2,2
Weight	kg	163
Dimensions (WxDxH)	cm	55x55x115

MAIN FEATURES

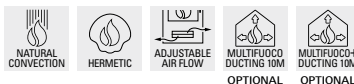

GENERAL CHARACTERISTICS

- Steel firebox
- Majolica cladding
- Aluker fireplace
- Cast iron/Skamolex brazier
- Steel door
- Top flue outlet
- Rear flue outlet
- Humidifier
- Air wash
- Tertiary air
- Removable ash box
- Orientable front ventilation
- OPTIONAL
- Vacuum

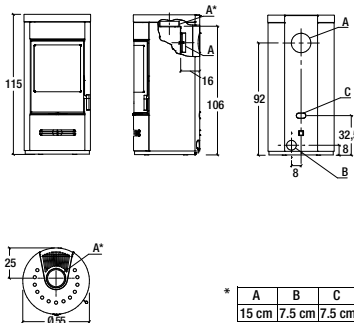

Model: E929 M Hermetic

COLORI - COLOURS - COULEURS - FARBEN - COLORES



E929 M BCS

Hermetic



Energy class		A+
Type		SL311-04
Room heating capacity	m ³	130 - 225
Nominal heat output	kW	7,8
Thermal efficiency	%	87,6
Nominal consumption	kg/h	2,1
Weight	kg	163
Dimensions (WxDxH)	cm	55x55x115

MAIN FEATURES

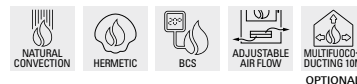

GENERAL CHARACTERISTICS

- Steel firebox
- Majolica cladding
- Aluker fireplace
- Cast iron/Skamolex brazier
- Steel door
- Top flue outlet
- Rear flue outlet
- Humidifier
- Air wash
- Tertiary air
- Removable ash box
- Orientable front ventilation
- OPTIONAL
- Vacuum

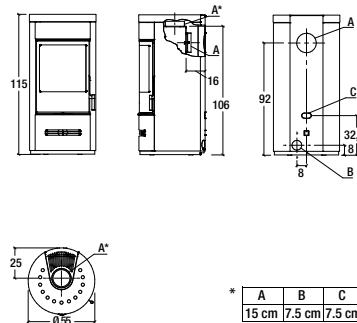

Model: E929 M BCS

COLORI - COLOURS - COULEURS - FARBEN - COLORES



E929 M-H

Hermetic



Energy class		A+
Type		SL310-04
Room heating capacity	m ³	135 - 230
Nominal heat output	kW	7,9
Thermal efficiency	%	85,7
Nominal consumption	kg/h	2,2
Weight	kg	191
Weight with HSS	kg	357
Dimensions (WxDxH)	cm	55x55x170

MAIN FEATURES



GENERAL CHARACTERISTICS

- Natural convection
- Steel firebox
- Aluker fireplace
- Cast iron/Skamolex brazier
- Steel door
- Top flue outlet
- Rear flue outlet
- Air wash
- Orientable front ventilation
- Tertiary air
- Removable ash box
- Vacuum

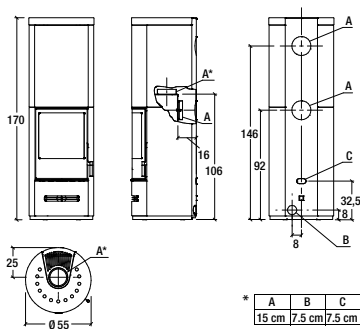

Model: E929 M-H Hermetic

COLORI - COLOURS - COULEURS - FARBEN - COLORES



E929 M-H BCS

Hermetic



Energy class		A+
Type		SL311-04
Room heating capacity	m ³	130 - 225
Nominal heat output	kW	7,8
Thermal efficiency	%	87,6
Nominal consumption	kg/h	2,1
Weight	kg	191
Weight with HSS	kg	357
Dimensions (WxDxH)	cm	55x55x170

MAIN FEATURES



GENERAL CHARACTERISTICS

- Natural convection
- Steel firebox
- Aluker fireplace
- Cast iron/Skamolex brazier
- Steel door
- Top flue outlet
- Rear flue outlet
- Air wash
- Orientable front ventilation
- Tertiary air
- Removable ash box
- Vacuum

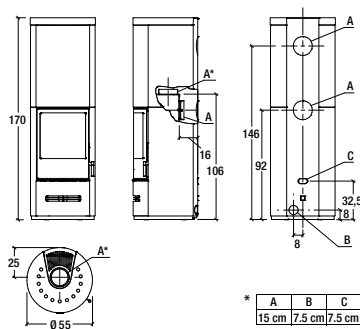

Model: E929 M-H BCS

COLORI - COLOURS - COULEURS - FARBEN - COLORES



E929 T

Hermetic



Energy class		A+
Type		SL310-04
Room heating capacity	m ³	135 - 230
Nominal heat output	kW	7,9
Thermal efficiency	%	85,7
Nominal consumption	kg/h	2,2
Weight	kg	183
Weight with HSS	kg	250
Dimensions (WxDxH)	cm	58x58x153

MAIN FEATURES



GENERAL CHARACTERISTICS

- Natural convection
- Steel firebox
- Aluker fireplace
- Cast iron/Skamolex brazier
- Steel door
- Top flue outlet
- Rear flue outlet
- Air wash
- Orientable front ventilation
- Tertiary air
- Removable ash box
- Vacuum

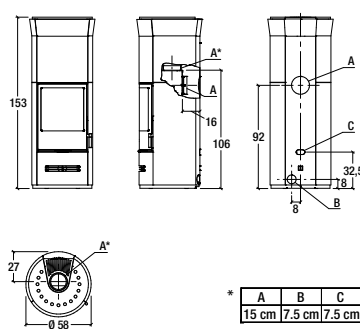

Model: E929 T Hermetic

COLORI - COLOURS - COULEURS - FARBEN - COLORES



Stile e arredo

E929 T BCS

Hermetic



Energy class		A+
Type		SL311-04
Room heating capacity	m ³	130 - 225
Nominal heat output	kW	7,8
Thermal efficiency	%	87,6
Nominal consumption	kg/h	2,1
Weight	kg	183
Weight with HSS	kg	250
Dimensions (WxDxH)	cm	58x58x153

MAIN FEATURES



GENERAL CHARACTERISTICS

- Natural convection
- Steel firebox
- Aluker fireplace
- Cast iron/Skamolex brazier
- Steel door
- Top flue outlet
- Rear flue outlet
- Air wash
- Orientable front ventilation
- Tertiary air
- Removable ash box
- OPTIONAL
- Vacuum

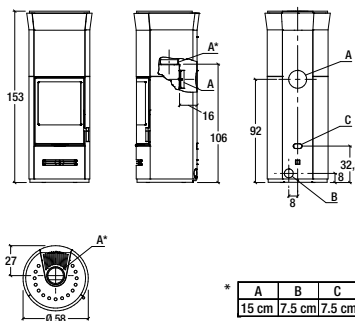

COLORI - COLOURS - COULEURS - FARBEN - COLORES

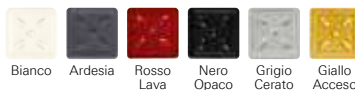

ROUND

Hermetic



Energy class		A+
Type		SL310-04
Room heating capacity	m ³	135 - 230
Nominal heat output	kW	7,9
Thermal efficiency	%	85,7
Nominal consumption	kg/h	2,2
Weight	kg	162
Dimensions (WxDxH)	cm	54x54x110
Dimens. with feet (WxDxH)	cm	54x54x120

MAIN FEATURES



GENERAL CHARACTERISTICS

- Natural convection
- Steel firebox
- Aluker fireplace
- Cast iron/Skamolex brazier
- Steel door
- Top flue outlet
- Rear flue outlet
- Air wash
- Tertiary air
- Removable ash box
- Orientable front ventilation
- Humidifier
- Removable steel feet
- OPTIONAL
- Vacuum

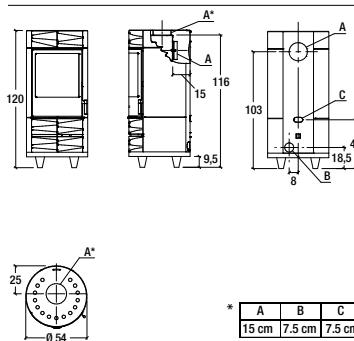

COLORI - COLOURS - COULEURS - FARBEN - COLORES

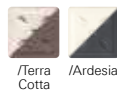

p.62

ROUND BCS

Hermetic



Energy class		A+
Type		SL311-04
Room heating capacity	m ³	130 - 225
Nominal heat output	kW	7,8
Thermal efficiency	%	87,6
Nominal consumption	kg/h	2,1
Weight	kg	162
Dimensions (WxDxH)	cm	54x54x110
Dimens. with feet (WxDxH)	cm	54x54x120

MAIN FEATURES



GENERAL CHARACTERISTICS

- Natural convection
- Steel firebox
- Aluker fireplace
- Cast iron/Skamolex brazier
- Steel door
- Top flue outlet
- Rear flue outlet
- Air wash
- Tertiary air
- Removable ash box
- Orientable front ventilation
- Humidifier
- Removable steel feet
- OPTIONAL
- Vacuum

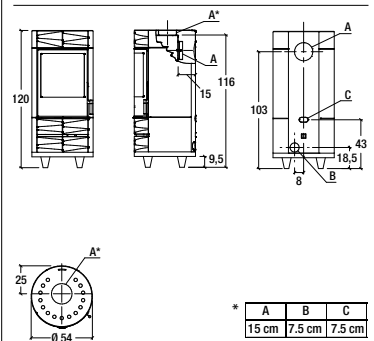

COLORI - COLOURS - COULEURS - FARBEN - COLORES

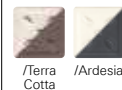

p.64

p.64

ROUND H

Hermetic



Energy class	A+
Type	SL310-04
Room heating capacity	m ³ 135 - 230
Nominal heat output	kW 7,9
Thermal efficiency	% 85,7
Nominal consumption	kg/h 2,2
Weight	kg 185
Weight with HSS	kg 318
Dim. (WxDxH) cm	54x54x156 (166 with feet)

MAIN FEATURES



GENERAL CHARACTERISTICS

- Natural convection
- Steel firebox
- Aluker fireplace
- Cast iron/Skamolex brazier
- Steel door
- Top flue outlet
- Rear flue outlet
- Air wash
- Orientable front ventilation
- Tertiary air
- Removable ash box
- Removable steel feet
- OPTIONAL
- Vacuum

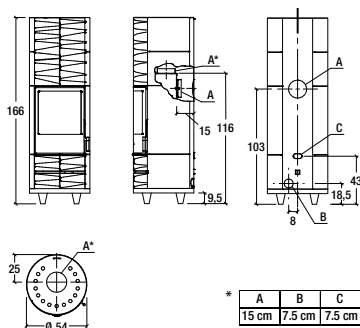

Model: ROUND-H Hermetic

COLORI - COLOURS - COULEURS - FARBEN - COLORES



p.68

ROUND H BCS

Hermetic



Energy class	A+
Type	SL311-04
Room heating capacity	m ³ 130 - 225
Nominal heat output	kW 7,8
Thermal efficiency	% 87,6
Nominal consumption	kg/h 2,1
Weight	kg 185
Weight with HSS	kg 318
Dim. (WxDxH) cm	54x54x156 (166 with feet)

MAIN FEATURES



GENERAL CHARACTERISTICS

- Natural convection
- Steel firebox
- Aluker fireplace
- Cast iron/Skamolex brazier
- Steel door
- Top flue outlet
- Rear flue outlet
- Air wash
- Orientable front ventilation
- Tertiary air
- Removable ash box
- Removable steel feet
- OPTIONAL
- Vacuum

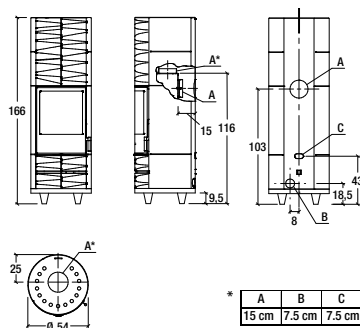

Model: ROUND-H BCS

COLORI - COLOURS - COULEURS - FARBEN - COLORES



p.68

ROUND M

Hermetic



Energy class	A+
Type	SL310-04
Room heating capacity	m ³ 135 - 230
Nominal heat output	kW 7,9
Thermal efficiency	% 85,7
Nominal consumption	kg/h 2,2
Weight	kg 170
Weight with HSS	kg 204
Dim. (WxDxH) cm	54x54x126 (136 with feet)

MAIN FEATURES



GENERAL CHARACTERISTICS

- Natural convection
- Steel firebox
- Aluker fireplace
- Cast iron/Skamolex brazier
- Steel door
- Top flue outlet
- Rear flue outlet
- Air wash
- Orientable front ventilation
- Tertiary air
- Removable ash box
- Removable steel feet
- OPTIONAL
- Vacuum

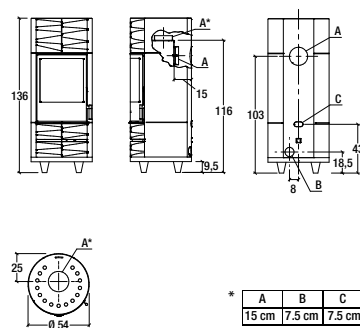

Model: ROUND-M Hermetic

COLORI - COLOURS - COULEURS - FARBEN - COLORES



p.66

Stile e arredo

ROUND M BCS

Hermetic



Energy class		A+
Type		SL311-04
Room heating capacity	m ³	130 - 225
Nominal heat output	kW	7,8
Thermal efficiency	%	87,6
Nominal consumption	kg/h	2,1
Weight	kg	170
Weight with HSS	kg	204
Dim. (WxDxH) cm		54x54x126 (136 with feet)

MAIN FEATURES



GENERAL CHARACTERISTICS

- Natural convection
- Steel firebox
- Steel firebox
- Aluker fireplace
- Cast iron/Skamolex brazier
- Steel door
- Top flue outlet
- Rear flue outlet
- Air wash
- Orientable front ventilation
- Tertiary air
- Removable ash box
- Removable steel feet
- OPTIONAL
- Vacuum

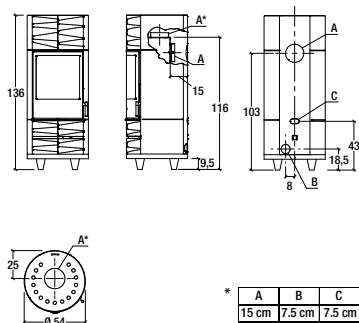

Model: ROUND-M BCS

COLORI - COLOURS - COULEURS - FARBEN - COLORES

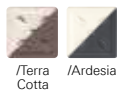

p.66

QUBE 1



Energy class		A
Type		SL321-02
Room heating capacity	m ³	150 - 260
Nominal heat output	kW	9,0
Thermal efficiency	%	80,5
Nominal consumption	kg/h	2,7
Weight	kg	150
Dimensions (WxDxH) cm		60x47x63

MAIN FEATURES



GENERAL CHARACTERISTICS

- Steel firebox
- Majolica cladding
- Aluker fireplace
- Cast iron brazier
- Cast iron door
- Top flue outlet
- Rear flue outlet
- Air wash
- Removable ash box
- Orientable front ventilation
- OPTIONAL
- Vacuum

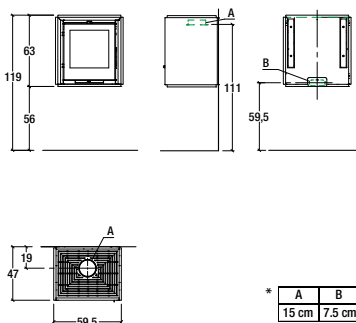

Model: QUBE

COLORI - COLOURS - COULEURS - FARBEN - COLORES



p.100

QUBE 1

with shelf



Energy class		A
Type		SL321-02
Room heating capacity	m ³	150 - 260
Nominal heat output	kW	9,0
Thermal efficiency	%	80,5
Nominal consumption	kg/h	2,7
Weight	kg	180
Dimensions (WxDxH) cm		60x47x63

MAIN FEATURES



GENERAL CHARACTERISTICS

- Steel firebox
- Majolica cladding
- Aluker fireplace
- Cast iron brazier
- Cast iron door
- Top flue outlet
- Rear flue outlet
- Air wash
- Removable ash box
- Orientable front ventilation
- OPTIONAL
- Vacuum

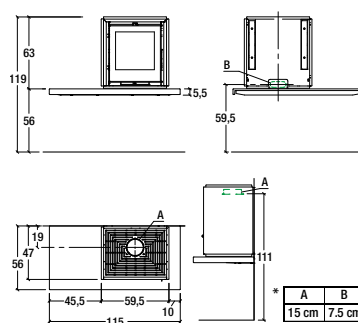

Model: QUBE

COLORI - COLOURS - COULEURS - FARBEN - COLORES



p.100

QUBE 2



Energy class		A
Type		SL321-02
Room heating capacity	m ³	150 - 260
Nominal heat output	kW	9,0
Thermal efficiency	%	80,5
Nominal consumption	kg/h	2,7
Weight	kg	205
Dimensions (WxDxH)	cm	60x47x119

MAIN FEATURES



GENERAL CHARACTERISTICS

- Steel firebox **OPTIONAL**
- Majolica cladding
- Aluker fireplace
- Cast iron brazier
- Cast iron door
- Top flue outlet
- Rear flue outlet
- Air wash
- Removable ash box
- Orientable front ventilation
- Vacuum

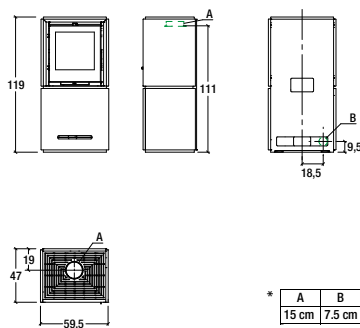

Model: QUBE

COLORI - COLOURS - COULEURS - FARBEN - COLORES



Bianco Antico Sahara Giallo Acceso Rosso Lava Ardesia

QUBE 3



Energy class		A
Type		SL321-02
Room heating capacity	m ³	150 - 260
Nominal heat output	kW	9,0
Thermal efficiency	%	80,5
Nominal consumption	kg/h	2,7
Weight	kg	211
Dimensions (WxDxH)	cm	60x47x124

MAIN FEATURES



GENERAL CHARACTERISTICS

- Steel firebox **OPTIONAL**
- Majolica cladding
- Aluker fireplace
- Cast iron brazier
- Cast iron door
- Top flue outlet
- Rear flue outlet
- Air wash
- Removable ash box
- Orientable front ventilation
- Vacuum

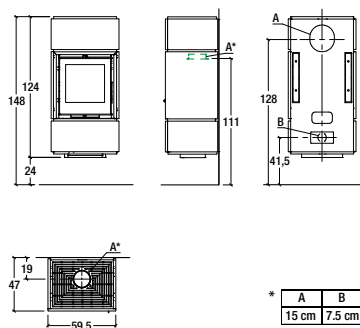

Model: QUBE

COLORI - COLOURS - COULEURS - FARBEN - COLORES



Bianco Antico Sahara Giallo Acceso Rosso Lava Ardesia

QUBE 4



Energy class		A
Type		SL321-02
Room heating capacity	m ³	150 - 260
Nominal heat output	kW	9,0
Thermal efficiency	%	80,5
Nominal consumption	kg/h	2,7
Weight	kg	250
Dimensions (WxDxH)	cm	60x47x175

MAIN FEATURES



GENERAL CHARACTERISTICS

- Steel firebox **OPTIONAL**
- Majolica cladding
- Aluker fireplace
- Cast iron brazier
- Cast iron door
- Top flue outlet
- Rear flue outlet
- Air wash
- Removable ash box
- Orientable front ventilation
- Vacuum

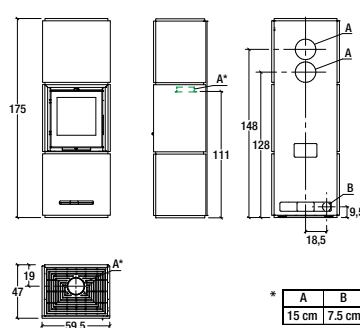

Model: QUBE

COLORI - COLOURS - COULEURS - FARBEN - COLORES



Bianco Antico Sahara Giallo Acceso Rosso Lava Ardesia

Stile e arredo

THELMA



Energy class		A
Type		SL322-02
Room heating capacity	m ³	150 - 260
Nominal heat output	kW	9,0
Thermal efficiency	%	80,5
Nominal consumption	kg/h	2,7
Weight	kg	165
Dimensions (WxDxH)	cm	71x46x100

MAIN FEATURES



GENERAL CHARACTERISTICS

- Steel firebox
 - Majolica cladding
 - Aluiker fireplace
 - Cast iron brazier
 - Cast iron door
 - Top flue outlet
 - Air wash
 - Humidifier
 - Removable ash box
 - Orientable front ventilation
- OPTIONAL
- Vacuum

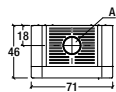
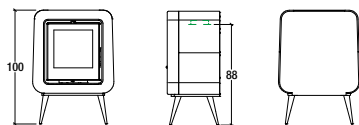

*	A	B
	15 cm	7,5 cm

Model: THELMA

COLORI - COLOURS - COULEURS - FARBEN - COLORES



Bianco Crema Anice Tè Verde Cipria Moka

E124

Hermetic



Energy class		A+
Type		SL300-03
Room heating capacity	m ³	120 - 210
Nominal heat output	kW	7,2
Thermal efficiency	%	85,1
Nominal consumption	kg/h	1,9
Weight	kg	150
Weight with HSS	kg	190
Dimensions (WxDxH)	cm	49x49x115

MAIN FEATURES



GENERAL CHARACTERISTICS

- Natural convection
- Steel firebox
- Steel cladding
- Majolica top
- Aluker fireplace
- Cast iron/Skamolex brazier
- Steel door
- Top flue outlet
- Air wash
- Tertiary air
- Removable ash box
- Humidifier OPTIONAL
- Rear flue outlet
- Vacuum

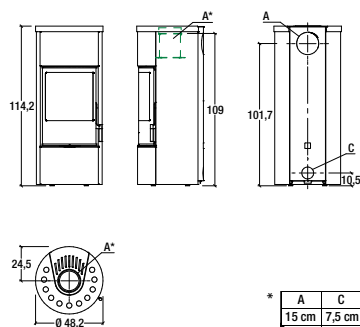

COLORI - COLOURS - COULEURS - FARBEN - COLORES



Bianco Opaco
Nero Opaco

E124 BCS

Hermetic



Energy class		A+
Type		SL301-03
Room heating capacity	m ³	120 - 210
Nominal heat output	kW	7,2
Thermal efficiency	%	85,3
Nominal consumption	kg/h	1,9
Weight	kg	150
Weight with HSS	kg	190
Dimensions (WxDxH)	cm	49x49x115

MAIN FEATURES



GENERAL CHARACTERISTICS

- Natural convection
- Steel firebox
- Steel cladding
- Majolica top
- Aluker fireplace
- Cast iron/Skamolex brazier
- Steel door
- Top flue outlet
- Air wash
- Tertiary air
- Removable ash box
- Humidifier OPTIONAL
- Rear flue outlet
- Vacuum

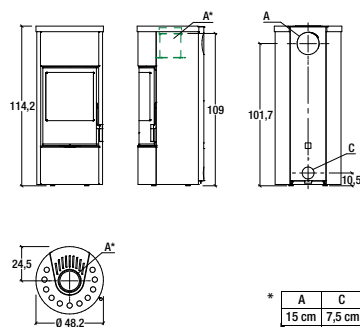

COLORI - COLOURS - COULEURS - FARBEN - COLORES



Bianco Opaco
Nero Opaco

E124 A

Hermetic



Energy class		A+
Type		SL300-03
Room heating capacity	m ³	120 - 210
Nominal heat output	kW	7,2
Thermal efficiency	%	85,1
Nominal consumption	kg/h	1,9
Weight	kg	115
Dimensions (WxDxH)	cm	49x49x125

MAIN FEATURES



GENERAL CHARACTERISTICS

- Natural convection
- Steel firebox
- Steel cladding
- Majolica top
- Aluker fireplace
- Cast iron/Skamolex brazier
- Steel door
- Top flue outlet
- Air wash
- Removable ash box
- Humidifier OPTIONAL
- Vacuum

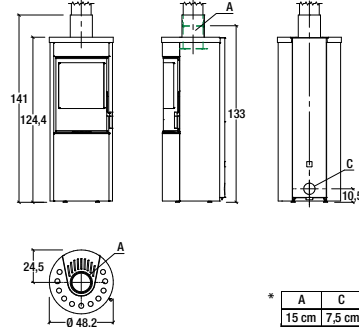

COLORI - COLOURS - COULEURS - FARBEN - COLORES



Bianco Opaco
Nero Opaco

E124 A BCS

Hermetic



Energy class		A+
Type		SL301-03
Room heating capacity	m ³	120 - 210
Nominal heat output	kW	7,2
Thermal efficiency	%	85,3
Nominal consumption	kg/h	1,9
Weight	kg	115
Dimensions (WxDxH)	cm	49x49x125

MAIN FEATURES



GENERAL CHARACTERISTICS

- Natural convection OPTIONAL
- Steel firebox
- Steel cladding
- Majolica top
- Aluker fireplace
- Cast iron/Skamolex brazier
- Steel door
- Top flue outlet
- Air wash
- Removable ash box
- Humidifier
- Vacuum

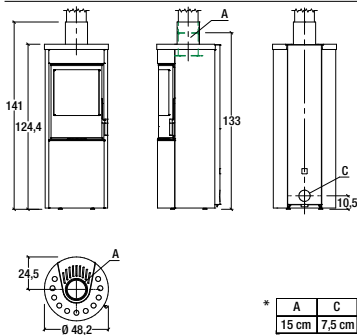

COLORI - COLOURS - COULEURS - FARBEN - COLORES



E128



Energy class		A+
Type		SL31-01
Room heating capacity	m ³	185 - 315
Nominal heat output	kW	11,0
Thermal efficiency	%	86,0
Nominal consumption	kg/h	2,9
Weight	kg	208
Dimensions (WxDxH)	cm	57x45x127

MAIN FEATURES



GENERAL CHARACTERISTICS

- Natural convection
- Steel firebox
- Steel cladding
- Majolica top
- Aluker fireplace
- Cast iron brazier
- Cast iron door
- Top flue outlet
- Rear flue outlet
- Air wash
- Tertiary air
- Removable ash box
- Humidifier
- Vacuum

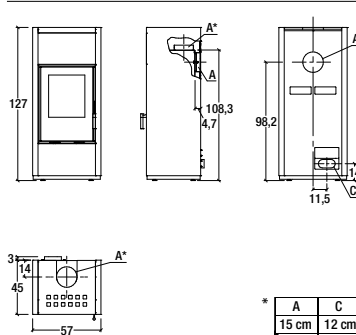

COLORI - COLOURS - COULEURS - FARBEN - COLORES



E128

Multifuoco® System



Energy class		A+
Type		SL31-03
Room heating capacity	m ³	185 - 315
Nominal heat output	kW	11,0
Thermal efficiency	%	87,4
Nominal consumption	kg/h	2,8
Weight	kg	212
Dimensions (WxDxH)	cm	57x45x127

MAIN FEATURES



GENERAL CHARACTERISTICS

- Natural convection
- Steel firebox
- Steel cladding
- Majolica top
- Aluker fireplace
- Cast iron brazier
- Cast iron door
- Top flue outlet
- Rear flue outlet
- Air wash
- Tertiary air
- Removable ash box
- Orientable front ventilation
- Humidifier
- Vacuum

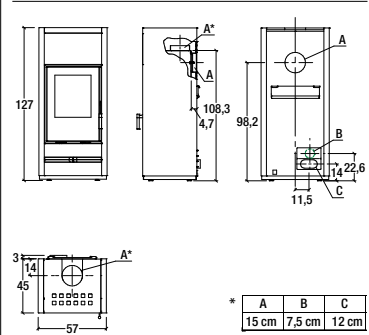

COLORI - COLOURS - COULEURS - FARBEN - COLORES



E128 BCS

Hermetic



Energy class		A+
Type		SL32-01
Room heating capacity	m ³	185 - 320
Nominal heat output	kW	11,1
Thermal efficiency	%	86,6
Nominal consumption	kg/h	2,9
Weight	kg	232
Weight with HSS	kg	262
Dimensions (WxDxH)	cm	57x45x127

MAIN FEATURES



GENERAL CHARACTERISTICS

- Natural convection
- Steel firebox
- Steel cladding
- Majolica top
- Aluker fireplace
- Cast iron brazier
- Cast iron door
- Top flue outlet
- Rear flue outlet
- Air wash
- Tertiary air
- Removable ash box
- OPTIONAL
 - Humidifier
 - Vacuum

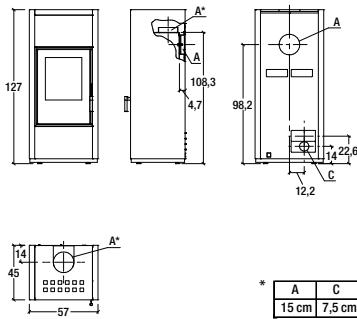

COLORI - COLOURS - COULEURS - FARBEN - COLORES



E128 BCS

Hermetic - Multifuoco® System



Energy class		A+
Type		SL32-03
Room heating capacity	m ³	185 - 315
Nominal heat output	kW	11,0
Thermal efficiency	%	87,2
Nominal consumption	kg/h	2,8
Weight	kg	236
Weight with HSS	kg	262
Dimensions (WxDxH)	cm	57x45x127

MAIN FEATURES

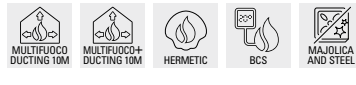

GENERAL CHARACTERISTICS

- Natural convection
- Steel firebox
- Steel cladding
- Majolica top
- Aluker fireplace
- Cast iron brazier
- Steel door
- Top flue outlet
- Rear flue outlet
- Air wash
- Tertiary air
- Removable ash box
- Orientable front ventilation
- OPTIONAL
 - HSS
 - Humidifier
 - Vacuum

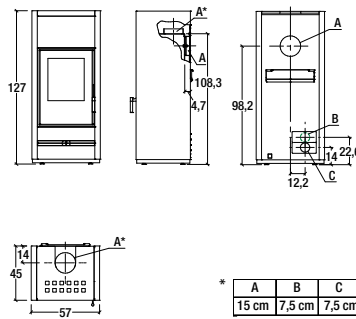

COLORI - COLOURS - COULEURS - FARBEN - COLORES



E128 A



Energy class		A+
Type		SL31-01
Room heating capacity	m ³	185 - 315
Nominal heat output	kW	11,0
Thermal efficiency	%	86,0
Nominal consumption	kg/h	2,9
Weight	kg	220
Dimensions (WxDxH)	cm	57x45x141

MAIN FEATURES



GENERAL CHARACTERISTICS

- Natural convection
- Steel firebox
- Steel cladding
- Majolica top
- Aluker fireplace
- Cast iron brazier
- Cast iron door
- Top flue outlet
- Rear flue outlet
- Air wash
- Removable ash box
- OPTIONAL
 - Humidifier
 - Vacuum

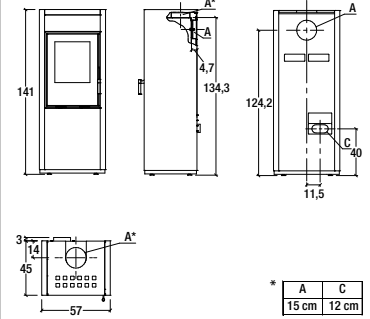

COLORI - COLOURS - COULEURS - FARBEN - COLORES



E128 A

Multifuoco® System



Energy class		A+
Type		SL31-03
Room heating capacity	m ³	185 - 315
Nominal heat output	kW	11,0
Thermal efficiency	%	87,4
Nominal consumption	kg/h	2,8
Weight	kg	224
Dimensions (WxDxH)	cm	57x45x141

MAIN FEATURES



GENERAL CHARACTERISTICS

- Natural convection
 - Steel firebox
 - Steel cladding
 - Majolica top
 - Aluker fireplace
 - Cast iron brazier
 - Cast iron door
 - Top flue outlet
 - Rear flue outlet
 - Orientable front ventilation
 - Air wash
 - Removable ash box
- OPTIONAL
- Humidifier
 - Vacuum

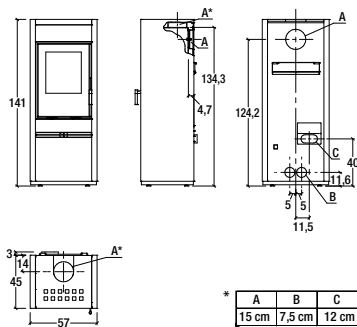

COLORI - COLOURS - COULEURS - FARBEN - COLORES



E128 A BCS

Hermetic



Energy class		A+
Type		SL32-01
Room heating capacity	m ³	185 - 320
Nominal heat output	kW	11,1
Thermal efficiency	%	86,6
Nominal consumption	kg/h	2,9
Weight	kg	238
Dimensions (WxDxH)	cm	57x45x141

MAIN FEATURES



GENERAL CHARACTERISTICS

- Natural convection
 - Steel firebox
 - Steel cladding
 - Majolica top
 - Aluker fireplace
 - Cast iron brazier
 - Cast iron door
 - Top flue outlet
 - Rear flue outlet
 - Air wash
 - Removable ash box
- OPTIONAL
- Humidifier
 - Vacuum

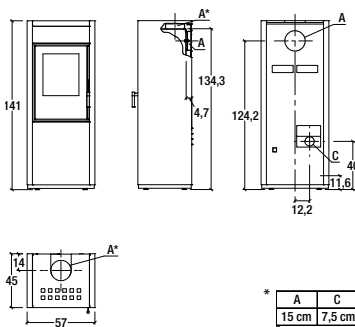

COLORI - COLOURS - COULEURS - FARBEN - COLORES



E128 A BCS

Hermetic - Multifuoco® System



Energy class		A+
Type		SL32-03
Room heating capacity	m ³	185 - 315
Nominal heat output	kW	11,0
Thermal efficiency	%	87,2
Nominal consumption	kg/h	2,8
Weight	kg	242
Dimensions (WxDxH)	cm	57x45x141

MAIN FEATURES



GENERAL CHARACTERISTICS

- Natural convection
 - Steel firebox
 - Steel cladding
 - Majolica top
 - Aluker fireplace
 - Cast iron brazier
 - Cast iron door
 - Top flue outlet
 - Rear flue outlet
 - Air wash
 - Tertiary air
 - Removable ash box
 - Orientable front ventilation
- OPTIONAL
- Humidifier
 - Vacuum

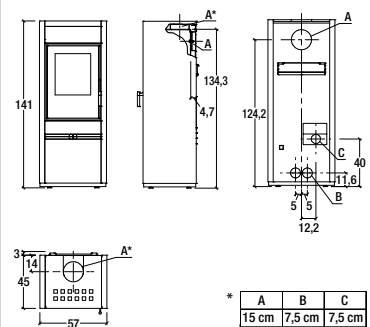

COLORI - COLOURS - COULEURS - FARBEN - COLORES



E129 M

Hermetic



Energy class		A+
Type		SL310-04
Room heating capacity	m ³	135 - 230
Nominal heat output	kW	7,9
Thermal efficiency	%	85,7
Nominal consumption	kg/h	2,2
Weight	kg	153
Dimensions (WxDxH)	cm	57x57x119

MAIN FEATURES



GENERAL CHARACTERISTICS

- Natural convection
- Steel firebox
- Steel cladding
- Majolica top
- Aluker fireplace
- Cast iron/Skamolex brazier
- Steel door
- Top flue outlet
- Rear flue outlet
- Air wash
- Removable ash box
- OPTIONAL
- Humidifier
- Vacuum

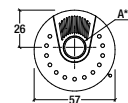
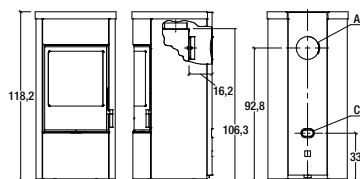

Model: E129 M

COLORI - COLOURS - COULEURS - FARBEN - COLORES



Bianco Opaco
Nero Opaco

E129 M

Hermetic - Multifuoco® System



Energy class		A+
Type		SL310-08
Room heating capacity	m ³	135 - 230
Nominal heat output	kW	7,9
Thermal efficiency	%	85,7
Nominal consumption	kg/h	2,2
Weight	kg	170
Dimensions (WxDxH)	cm	57x57x119

MAIN FEATURES



GENERAL CHARACTERISTICS

- Natural convection
- Steel firebox
- Steel cladding
- Majolica top
- Aluker fireplace
- Cast iron/Skamolex brazier
- Steel door
- Top flue outlet
- Rear flue outlet
- Air wash
- Tertiary air
- Removable ash box
- Orientable front ventilation
- OPTIONAL
- Humidifier
- Vacuum

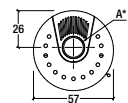

Model: E129 M

COLORI - COLOURS - COULEURS - FARBEN - COLORES



Bianco Opaco
Nero Opaco

E129 M BCS

Hermetic



Energy class		A+
Type		SL311-04
Room heating capacity	m ³	130 - 225
Nominal heat output	kW	7,8
Thermal efficiency	%	87,6
Nominal consumption	kg/h	2,1
Weight	kg	163
Dimensions (WxDxH)	cm	57x57x119

MAIN FEATURES



GENERAL CHARACTERISTICS

- Natural convection
- Steel firebox
- Steel cladding
- Majolica top
- Aluker fireplace
- Cast iron/Skamolex brazier
- Steel door
- Top flue outlet
- Rear flue outlet
- Air wash
- Tertiary air
- Removable ash box
- OPTIONAL
- Humidifier
- Vacuum

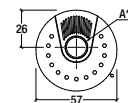

Model: E129 M BCS

COLORI - COLOURS - COULEURS - FARBEN - COLORES



Bianco Opaco
Nero Opaco

Trend Line

E129 M BCS

Hermetic - Multifuoco® System



Energy class		A+
Type		SL311-08
Room heating capacity	m ³	130 - 225
Nominal heat output	kW	7,8
Thermal efficiency	%	87,6
Nominal consumption	kg/h	2,1
Weight	kg	183
Dimensions (WxDxH)	cm	57x57x119

MAIN FEATURES



GENERAL CHARACTERISTICS

- Natural convection
 - Steel firebox
 - Steel cladding
 - Majolica top
 - Aluker fireplace
 - Cast iron brazier
 - Steel door
 - Top flue outlet
 - Rear flue outlet
 - Air wash
 - Tertiary air
 - Removable ash box
 - Orientable front ventilation
- OPTIONAL
- Humidifier
 - Vacuum

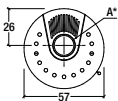

*	A	B	C
	15 cm	7,5 cm	7,5 cm

Model: E129 M BCS

COLORI - COLOURS - COULEURS - FARBEN - COLORES

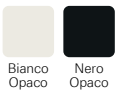

Bianco Opaco Nero Opaco

L'originale stufa-caminetto

BERNA

MC 65/60



Energy class		A
Type		MC 65/60
Room heating capacity	m ³	185 - 315
Nominal heat output	kW	11,0
Thermal efficiency	%	80,0
Nominal consumption	kg/h	3,1
Weight	kg	264
Dimensions (WxDxH)	cm	75x53x142

MAIN FEATURES

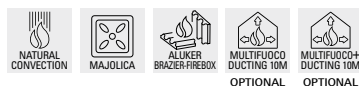

GENERAL CHARACTERISTICS

- Steel firebox
 - Aluker fireplace
 - Aluker brazier
 - Steel door
 - Top flue outlet
 - Air wash
 - Tertiary air
- OPTIONAL
- External air kit
 - Vacuum

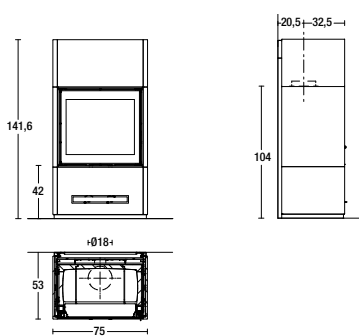

Model: BERNA

COLORI - COLOURS - COULEURS - FARBEN - COLORES



BERNA

MC 70/51



Energy class		A
Type		MC 70/51
Room heating capacity	m ³	185 - 315
Nominal heat output	kW	11,0
Thermal efficiency	%	79,0
Nominal consumption	kg/h	2,9
Weight	kg	246
Dimensions (WxDxH)	cm	80x53x133

MAIN FEATURES

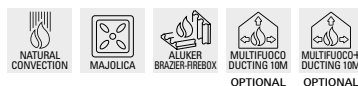

GENERAL CHARACTERISTICS

- Steel firebox
 - Aluker fireplace
 - Aluker brazier
 - Steel door
 - Top flue outlet
 - Air wash
 - Tertiary air
- OPTIONAL
- External air kit
 - Vacuum

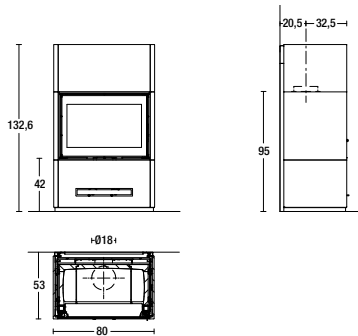

Model: BERNA

COLORI - COLOURS - COULEURS - FARBEN - COLORES



BERNA

MC 90/44



Energy class		A
Type		MC 90/44
Room heating capacity	m ³	205 - 350
Nominal heat output	kW	12,0
Thermal efficiency	%	79,3
Nominal consumption	kg/h	3,2
Weight	kg	262
Dimensions (WxDxH)	cm	100x53x126

MAIN FEATURES

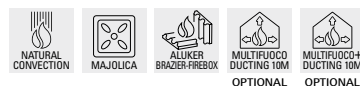

GENERAL CHARACTERISTICS

- Steel firebox
 - Aluker fireplace
 - Aluker brazier
 - Steel door
 - Top flue outlet
 - Air wash
 - Tertiary air
- OPTIONAL
- External air kit
 - Vacuum

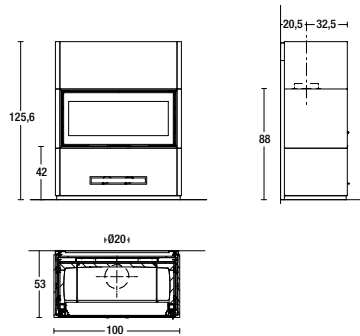

Model: BERNA

COLORI - COLOURS - COULEURS - FARBEN - COLORES



L'originale stufa-caminetto

BERNA

MC 120/48



Energy class		A
Type		MC 120/48
Room heating capacity	m ³	235 - 405
Nominal heat output	kW	14,0
Thermal efficiency	%	78,9
Nominal consumption	kg/h	3,8
Weight	kg	332
Dimensions (WxDxH)	cm	128x53x130

MAIN FEATURES

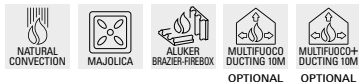

GENERAL CHARACTERISTICS

- Steel firebox
 - Aluker fireplace
 - Aluker brazier
 - Steel door
 - Top flue outlet
 - Air wash
 - Tertiary air
- OPTIONAL
- External air kit
 - Vacuum

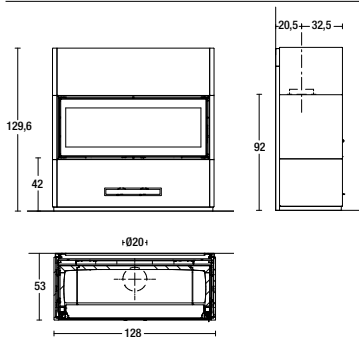

Model: BERNA

COLORI - COLOURS - COULEURS - FARBEN - COLORES



BERNA

MC 80/64 BL



Energy class		A
Type		MC 65/60
Room heating capacity	m ³	185 - 315
Nominal heat output	kW	11,0
Thermal efficiency	%	80,0
Nominal consumption	kg/h	3,1
Weight	kg	321
Dimensions (WxDxH)	cm	90x53x145

MAIN FEATURES



GENERAL CHARACTERISTICS

- Steel firebox
 - Aluker fireplace
 - Aluker brazier
 - Steel door
 - Top flue outlet
 - Air wash
 - Tertiary air
- OPTIONAL
- External air kit
 - Vacuum

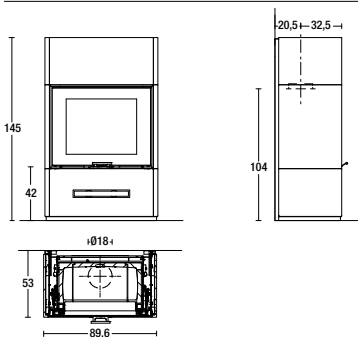

Model: BERNA

COLORI - COLOURS - COULEURS - FARBEN - COLORES



BERNA

MC 85/55 BL



Energy class		A
Type		MC 70/51
Room heating capacity	m ³	185 - 315
Nominal heat output	kW	11,0
Thermal efficiency	%	79,0
Nominal consumption	kg/h	2,9
Weight	kg	310
Dimensions (WxDxH)	cm	95x53x136

MAIN FEATURES

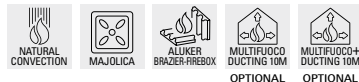

GENERAL CHARACTERISTICS

- Steel firebox
 - Aluker fireplace
 - Aluker brazier
 - Steel door
 - Top flue outlet
 - Air wash
 - Tertiary air
- OPTIONAL
- External air kit
 - Vacuum

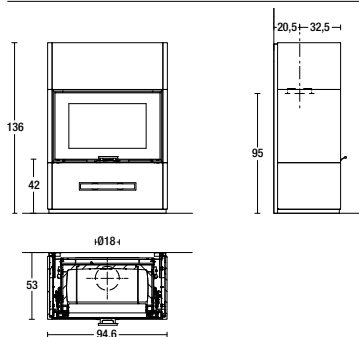

Model: BERNA

COLORI - COLOURS - COULEURS - FARBEN - COLORES



L'originale stufa-caminetto

BERNA MC 105/48 BL



Energy class		A
Type		MC 90/44
Room heating capacity	m ³	205 - 350
Nominal heat output	kW	12,0
Thermal efficiency	%	79,0
Nominal consumption	kg/h	3,2
Weight	kg	305
Dimensions (WxDxH)	cm	115x53x129

MAIN FEATURES

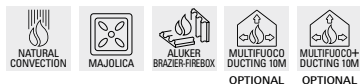

GENERAL CHARACTERISTICS

- Steel firebox
 - Aluker fireplace
 - Aluker brazier
 - Steel door
 - Top flue outlet
 - Air wash
 - Tertiary air
- OPTIONAL
- External air kit
 - Vacuum

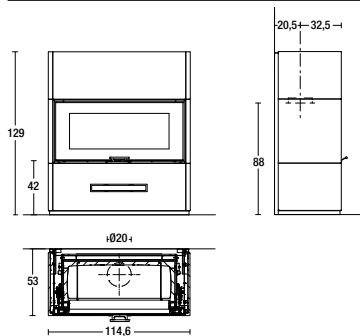

Model: BERNA

COLORI - COLOURS - COULEURS - FARBEN - COLORES



Bianco Terra Cotta Rosso Lava Nero Opaco

BERNA MC 133/52 BL



Energy class		A
Type		MC 120/48
Room heating capacity	m ³	235 - 405
Nominal heat output	kW	14,0
Thermal efficiency	%	79,0
Nominal consumption	kg/h	3,8
Weight	kg	426
Dimensions (WxDxH)	cm	143x53x133

MAIN FEATURES

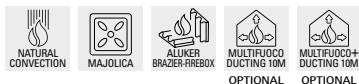

GENERAL CHARACTERISTICS

- Steel firebox
 - Aluker fireplace
 - Aluker brazier
 - Steel door
 - Top flue outlet
 - Air wash
 - Tertiary air
- OPTIONAL
- External air kit
 - Vacuum

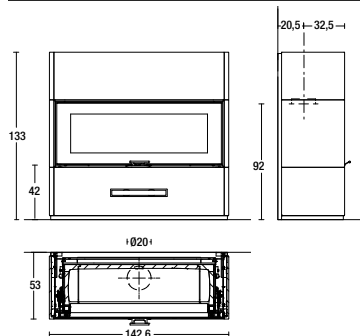

Model: BERNA

COLORI - COLOURS - COULEURS - FARBEN - COLORES



Bianco Terra Cotta Rosso Lava Nero Opaco

DAVOS MC 65/60



Energy class		A
Type		MC 65/60
Room heating capacity	m ³	185 - 315
Nominal heat output	kW	11,0
Thermal efficiency	%	80,0
Nominal consumption	kg/h	3,1
Weight	kg	291
Dimensions (WxDxH)	cm	75x53x186

MAIN FEATURES

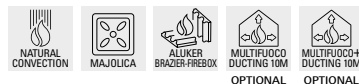

GENERAL CHARACTERISTICS

- Steel firebox
 - Aluker fireplace
 - Aluker brazier
 - Steel door
 - Top flue outlet
 - Air wash
 - Tertiary air
- OPTIONAL
- External air kit
 - Vacuum

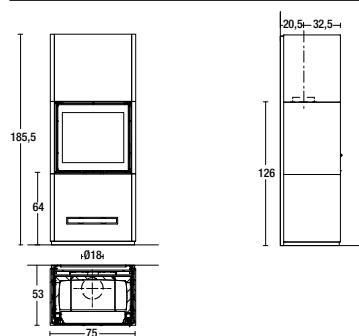

Model: DAVOS

COLORI - COLOURS - COULEURS - FARBEN - COLORES



Bianco Terra Cotta Rosso Lava Nero Opaco

L'originale stufa-caminetto

DAVOS

MC 70/51



Energy class		A
Type		MC 70/51
Room heating capacity	m ³	185 - 315
Nominal heat output	kW	11,0
Thermal efficiency	%	79,0
Nominal consumption	kg/h	2,9
Weight	kg	270
Dimensions (WxDxH)	cm	80x53x177

MAIN FEATURES

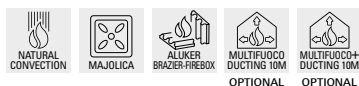

GENERAL CHARACTERISTICS

- Steel firebox
 - Aluker fireplace
 - Aluker brazier
 - Steel door
 - Top flue outlet
 - Air wash
 - Tertiary air
- OPTIONAL
- External air kit
 - Vacuum

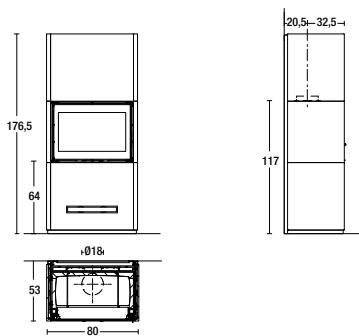

Model: DAVOS

COLORI - COLOURS - COULEURS - FARBEN - COLORES



DAVOS

MC 90/44



Energy class		A
Type		MC 90/44
Room heating capacity	m ³	205 - 350
Nominal heat output	kW	12,0
Thermal efficiency	%	79,3
Nominal consumption	kg/h	3,2
Weight	kg	284
Dimensions (WxDxH)	cm	100x53x170

MAIN FEATURES

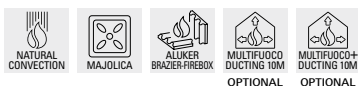

GENERAL CHARACTERISTICS

- Steel firebox
 - Aluker fireplace
 - Aluker brazier
 - Steel door
 - Top flue outlet
 - Air wash
 - Tertiary air
- OPTIONAL
- External air kit
 - Vacuum

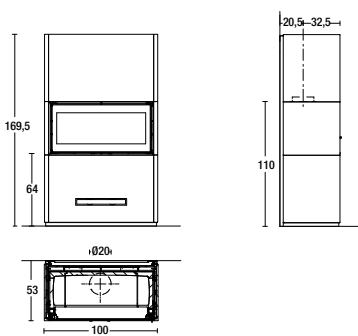

Model: DAVOS

COLORI - COLOURS - COULEURS - FARBEN - COLORES



DAVOS

MC 120/48



Energy class		A
Type		MC 120/48
Room heating capacity	m ³	235 - 405
Nominal heat output	kW	14,0
Thermal efficiency	%	78,9
Nominal consumption	kg/h	3,8
Weight	kg	327
Dimensions (WxDxH)	cm	128x53x174

MAIN FEATURES

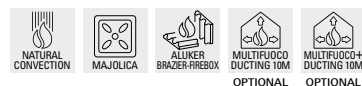

GENERAL CHARACTERISTICS

- Steel firebox
 - Aluker fireplace
 - Aluker brazier
 - Steel door
 - Top flue outlet
 - Air wash
 - Tertiary air
- OPTIONAL
- External air kit
 - Vacuum

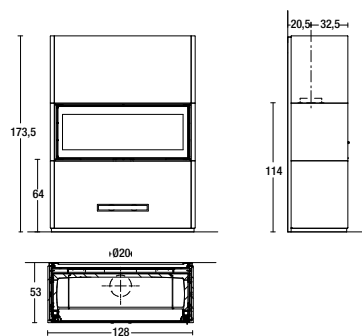

Model: DAVOS

COLORI - COLOURS - COULEURS - FARBEN - COLORES



L'originale stufa-caminetto

DAVOS

MC 80/64 BL



Energy class		A
Type		MC 65/60
Room heating capacity	m ³	185 - 315
Nominal heat output	kW	11,0
Thermal efficiency	%	80,0
Nominal consumption	kg/h	3,1
Weight	kg	352
Dimensions (WxDxH)	cm	90x53x189

MAIN FEATURES

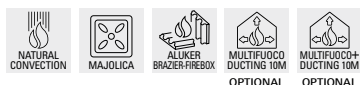

GENERAL CHARACTERISTICS

- Steel firebox
 - Aluker fireplace
 - Aluker brazier
 - Steel door
 - Top flue outlet
 - Air wash
 - Tertiary air
- OPTIONAL
- External air kit
 - Vacuum

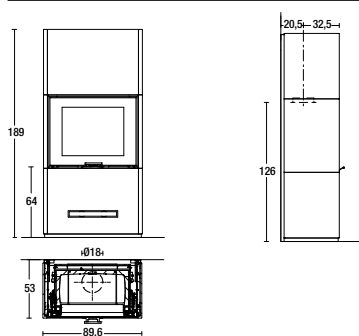

Model: DAVOS

COLORI - COLOURS - COULEURS - FARBEN - COLORES



Bianco Terra Cotta Rosso Lava Nero Opaco

p.112

DAVOS

MC 85/55 BL



Energy class		A
Type		MC 70/51
Room heating capacity	m ³	185 - 315
Nominal heat output	kW	11,0
Thermal efficiency	%	79,0
Nominal consumption	kg/h	2,9
Weight	kg	338
Dimensions (WxDxH)	cm	95x53x180

MAIN FEATURES

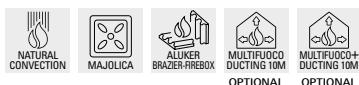

GENERAL CHARACTERISTICS

- Steel firebox
 - Aluker fireplace
 - Aluker brazier
 - Steel door
 - Top flue outlet
 - Air wash
 - Tertiary air
- OPTIONAL
- External air kit
 - Vacuum

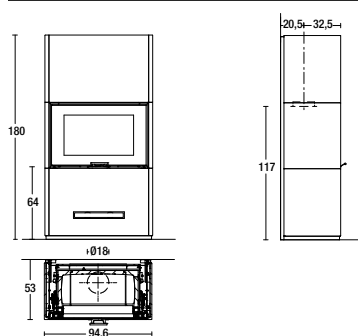

Model: DAVOS

COLORI - COLOURS - COULEURS - FARBEN - COLORES



Bianco Terra Cotta Rosso Lava Nero Opaco

p.112

DAVOS

MC 105/48 BL



Energy class		A
Type		MC 90/44
Room heating capacity	m ³	205 - 350
Nominal heat output	kW	12,0
Thermal efficiency	%	79,0
Nominal consumption	kg/h	3,2
Weight	kg	351
Dimensions (WxDxH)	cm	115x53x173

MAIN FEATURES

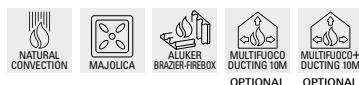

GENERAL CHARACTERISTICS

- Steel firebox
 - Aluker fireplace
 - Aluker brazier
 - Steel door
 - Top flue outlet
 - Air wash
 - Tertiary air
- OPTIONAL
- External air kit
 - Vacuum

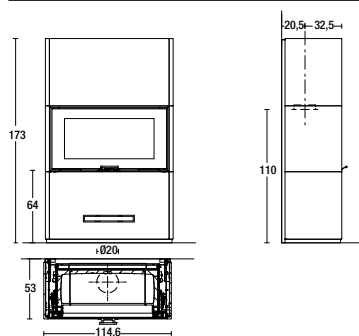

Model: DAVOS

COLORI - COLOURS - COULEURS - FARBEN - COLORES



Bianco Terra Cotta Rosso Lava Nero Opaco

p.112

L'originale stufa-caminetto

DAVOS

MC 133/52 BL



Energy class		A
Type		MC 120/48
Room heating capacity	m ³	235 - 405
Nominal heat output	kW	14,0
Thermal efficiency	%	79,0
Nominal consumption	kg/h	3,8
Weight	kg	514
Dimensions (WxDxH)	cm	143x53x177

MAIN FEATURES

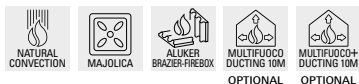

GENERAL CHARACTERISTICS

- Steel firebox
 - Aluker fireplace
 - Aluker brazier
 - Steel door
 - Top flue outlet
 - Air wash
 - Tertiary air
- OPTIONAL
- External air kit
 - Vacuum

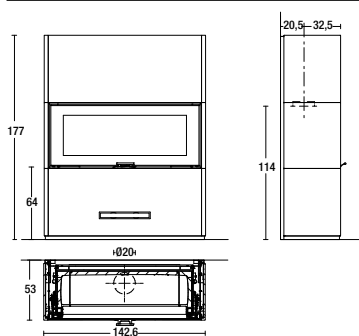

Model: DAVOS

COLORI - COLOURS - COULEURS - FARBEN - COLORES



Bianco Terra Cotta Rosso Lava Nero Opaco

LUGANO

MC 65/60



Energy class		A
Type		MC 65/60
Room heating capacity	m ³	185 - 315
Nominal heat output	kW	11,0
Thermal efficiency	%	80,0
Nominal consumption	kg/h	3,1
Weight	kg	263
Dimensions (WxDxH)	cm	75x53x141

MAIN FEATURES

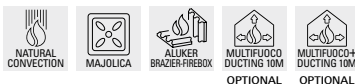

GENERAL CHARACTERISTICS

- Steel firebox
 - Aluker fireplace
 - Aluker brazier
 - Steel door
 - Top flue outlet
 - Air wash
 - Tertiary air
- OPTIONAL
- External air kit
 - Vacuum

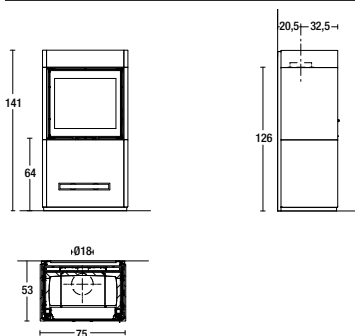

Model: LUGANO

COLORI - COLOURS - COULEURS - FARBEN - COLORES



Bianco Terra Cotta Rosso Lava Nero Opaco

LUGANO

MC 70/51



Energy class		A
Type		MC 70/51
Room heating capacity	m ³	185 - 315
Nominal heat output	kW	11,0
Thermal efficiency	%	79,0
Nominal consumption	kg/h	2,9
Weight	kg	245
Dimensions (WxDxH)	cm	80x53x132

MAIN FEATURES

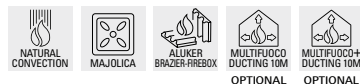

GENERAL CHARACTERISTICS

- Steel firebox
 - Aluker fireplace
 - Aluker brazier
 - Steel door
 - Top flue outlet
 - Air wash
 - Tertiary air
- OPTIONAL
- External air kit
 - Vacuum

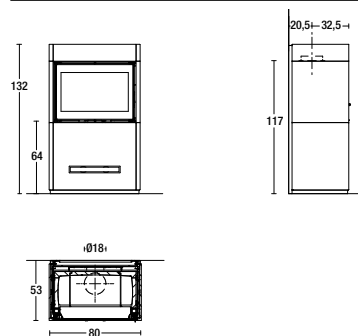

Model: LUGANO

COLORI - COLOURS - COULEURS - FARBEN - COLORES



Bianco Terra Cotta Rosso Lava Nero Opaco

L'originale stufa-caminetto

LUGANO

MC 90/44



Energy class		A
Type		MC 90/44
Room heating capacity	m ³	205 - 350
Nominal heat output	kW	12,0
Thermal efficiency	%	79,3
Nominal consumption	kg/h	3,2
Weight	kg	260
Dimensions (WxDxH)	cm	100x53x125

MAIN FEATURES

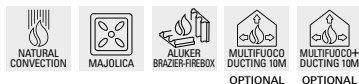

GENERAL CHARACTERISTICS

- Steel firebox
 - Aluker fireplace
 - Aluker brazier
 - Steel door
 - Top flue outlet
 - Air wash
 - Tertiary air
- OPTIONAL
- External air kit
 - Vacuum

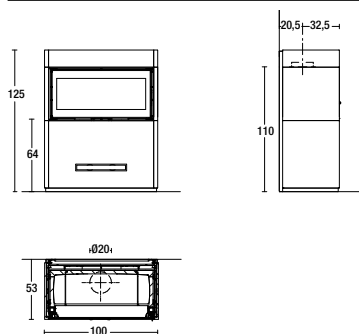

Model: LUGANO

COLORI - COLOURS - COULEURS - FARBEN - COLORES



Bianco Terra Cotta Rosso Lava Nero Opaco

p.116

LUGANO

MC 120/48



Energy class		A
Type		MC 120/48
Room heating capacity	m ³	235 - 405
Nominal heat output	kW	14,0
Thermal efficiency	%	78,9
Nominal consumption	kg/h	3,8
Weight	kg	331
Dimensions (WxDxH)	cm	128x53x129

MAIN FEATURES

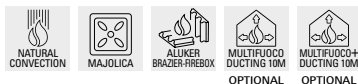

GENERAL CHARACTERISTICS

- Steel firebox
 - Aluker fireplace
 - Aluker brazier
 - Steel door
 - Top flue outlet
 - Air wash
 - Tertiary air
- OPTIONAL
- External air kit
 - Vacuum

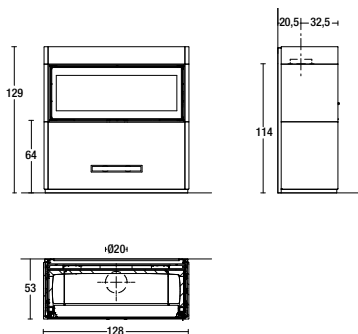

Model: LUGANO

COLORI - COLOURS - COULEURS - FARBEN - COLORES



Bianco Terra Cotta Rosso Lava Nero Opaco

p.116

LUGANO

MC 80/64 BL



Energy class		A
Type		MC 65/60
Room heating capacity	m ³	185 - 315
Nominal heat output	kW	11,0
Thermal efficiency	%	80,0
Nominal consumption	kg/h	3,1
Weight	kg	320
Dimensions (WxDxH)	cm	90x53x144

MAIN FEATURES

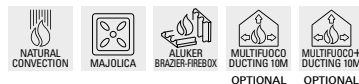

GENERAL CHARACTERISTICS

- Steel firebox
 - Aluker fireplace
 - Aluker brazier
 - Steel door
 - Top flue outlet
 - Air wash
 - Tertiary air
- OPTIONAL
- External air kit
 - Vacuum

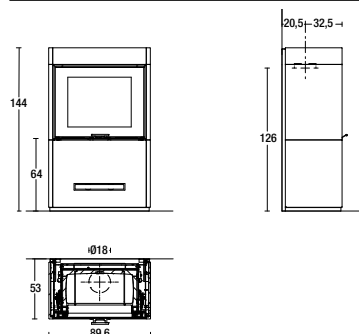

Model: LUGANO

COLORI - COLOURS - COULEURS - FARBEN - COLORES



Bianco Terra Cotta Rosso Lava Nero Opaco

p.116

L'originale stufa-caminetto

LUGANO

MC 85/55 BL



Energy class		A
Type		MC 70/51
Room heating capacity	m ³	185 - 315
Nominal heat output	kW	11,0
Thermal efficiency	%	79,0
Nominal consumption	kg/h	2,9
Weight	kg	308
Dimensions (WxDxH)	cm	95x53x135

MAIN FEATURES

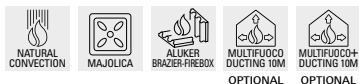

GENERAL CHARACTERISTICS

- Steel firebox
 - Aluker fireplace
 - Aluker brazier
 - Steel door
 - Top flue outlet
 - Air wash
 - Tertiary air
- OPTIONAL
- External air kit
 - Vacuum

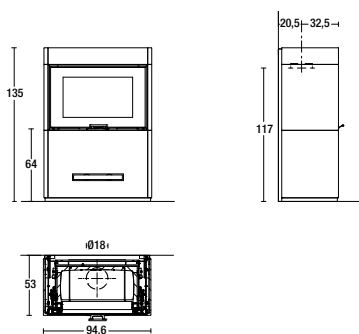

Model: LUGANO

COLORI - COLOURS - COULEURS - FARBEN - COLORES



LUGANO

MC 105/48 BL



Energy class		A
Type		MC 90/44
Room heating capacity	m ³	205 - 350
Nominal heat output	kW	12,0
Thermal efficiency	%	79,0
Nominal consumption	kg/h	3,2
Weight	kg	304
Dimensions (WxDxH)	cm	115x53x128

MAIN FEATURES

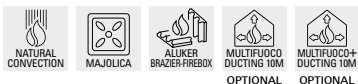

GENERAL CHARACTERISTICS

- Steel firebox
 - Aluker fireplace
 - Aluker brazier
 - Steel door
 - Top flue outlet
 - Air wash
 - Tertiary air
- OPTIONAL
- External air kit
 - Vacuum

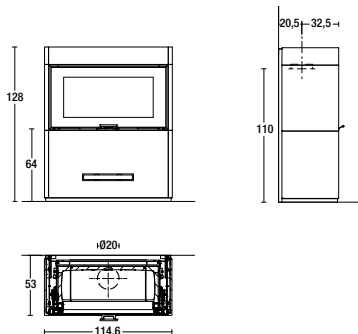

Model: LUGANO

COLORI - COLOURS - COULEURS - FARBEN - COLORES



LUGANO

MC 133/52 BL



Energy class		A
Type		MC 120/48
Room heating capacity	m ³	235 - 405
Nominal heat output	kW	14,0
Thermal efficiency	%	79,0
Nominal consumption	kg/h	3,8
Weight	kg	420
Dimensions (WxDxH)	cm	143x53x132

MAIN FEATURES

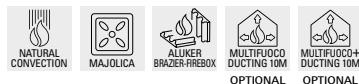

GENERAL CHARACTERISTICS

- Steel firebox
 - Aluker fireplace
 - Aluker brazier
 - Steel door
 - Top flue outlet
 - Air wash
 - Tertiary air
- OPTIONAL
- External air kit
 - Vacuum

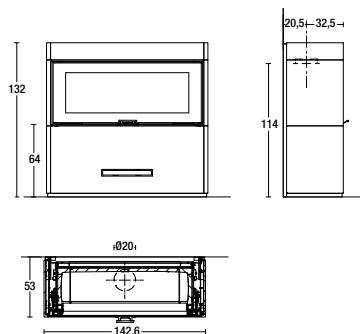

Model: LUGANO

COLORI - COLOURS - COULEURS - FARBEN - COLORES



L'originale stufa-caminetto

BRUNICO



Energy class		A+
Type		SL31-01
Room heating capacity	m ³	185 - 315
Nominal heat output	kW	11,0
Thermal efficiency	%	86,0
Nominal consumption	kg/h	2,9
Weight	kg	272
Dimensions (WxDxH)	cm	73x58x146

MAIN FEATURES



GENERAL CHARACTERISTICS

- Natural convection
- Steel firebox
- Aluker fireplace
- Cast iron brazier
- Cast iron door
- Top flue outlet
- Rear flue outlet
- Removable ash box
- Tertiary air
- Orientable front ventilation
- Air wash
- External air kit
- Vacuum

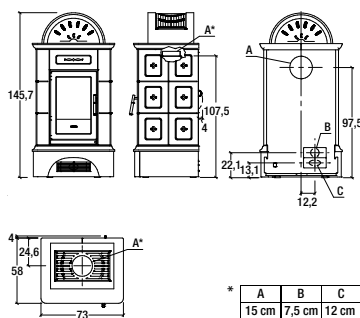

Model: BRUNICO

COLORI - COLOURS - COULEURS - FARBEN - COLORES



p.120

BRUNICO BCS

Hermetic



Energy class		A+
Type		SL32-01
Room heating capacity	m ³	185 - 320
Nominal heat output	kW	11,1
Thermal efficiency	%	86,6
Nominal consumption	kg/h	2,9
Weight	kg	280
Dimensions (WxDxH)	cm	73x58x146

MAIN FEATURES



GENERAL CHARACTERISTICS

- Natural convection
- Aluker fireplace
- Cast iron brazier
- Cast iron door
- Top flue outlet
- Rear flue outlet
- Removable ash box
- Air wash
- Tertiary air
- Orientable front ventilation
- External air kit
- Vacuum

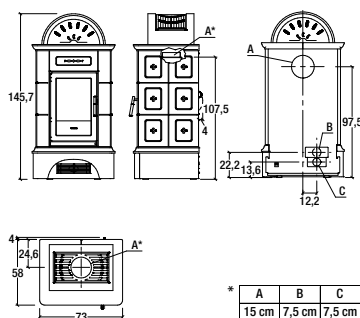

Model: BRUNICO BCS

COLORI - COLOURS - COULEURS - FARBEN - COLORES



p.120

CANAZEI



Energy class		A+
Type		SL31-01
Room heating capacity	m ³	185 - 315
Nominal heat output	kW	11,0
Thermal efficiency	%	86,0
Nominal consumption	kg/h	2,9
Weight	kg	288
Dimensions (WxDxH)	cm	75x59x147

MAIN FEATURES



GENERAL CHARACTERISTICS

- Natural convection
- Steel firebox
- Aluker fireplace
- Cast iron brazier
- Cast iron door
- Top flue outlet
- Rear flue outlet
- Removable ash box
- Tertiary air
- Orientable front ventilation
- Air wash
- External air kit
- Vacuum

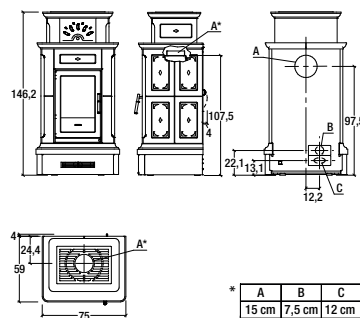

Model: CANAZEI

COLORI - COLOURS - COULEURS - FARBEN - COLORES



p.122

L'originale stufa-caminetto

CANAZEI BCS

Hermetic



Energy class		A+
Type		SL32-01
Room heating capacity	m ³	185 - 320
Nominal heat output	kW	11,1
Thermal efficiency	%	86,6
Nominal consumption	kg/h	2,9
Weight	kg	290
Dimensions (WxDxH)	cm	75x59x147

MAIN FEATURES



GENERAL CHARACTERISTICS

- Natural convection
- Aluker fireplace
- Cast iron brazier
- Cast iron door
- Top flue outlet
- Rear flue outlet
- Removable ash box
- Air wash
- Tertiary air
- Orientable front ventilation
- External air kit
- Vacuum

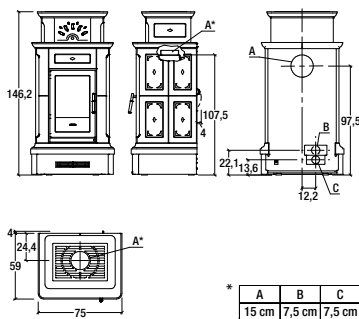

Model: CANAZEI BCS

COLORI - COLOURS - COULEURS - FARBEN - COLORES



p.122

ORTISEI



Energy class		A+
Type		SL31-01
Room heating capacity	m ³	185 - 315
Nominal heat output	kW	11,0
Thermal efficiency	%	86,0
Nominal consumption	kg/h	2,9
Weight	kg	327
Dimensions (WxDxH)	cm	100x58x147

MAIN FEATURES



GENERAL CHARACTERISTICS

- Natural convection
- Steel firebox
- Aluker fireplace
- Cast iron brazier
- Cast iron door
- Top flue outlet
- Rear flue outlet
- Removable ash box
- Air wash
- Orientable front ventilation
- Tertiary air
- External air kit
- Vacuum

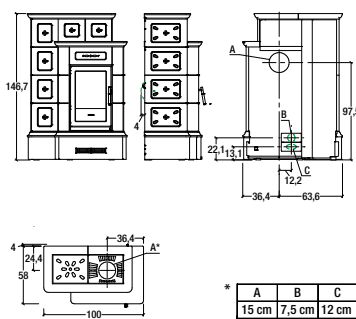

Model: ORTISEI

COLORI - COLOURS - COULEURS - FARBEN - COLORES



p.118

ORTISEI BCS

Hermetic



Energy class		A+
Type		SL32-01
Room heating capacity	m ³	185 - 320
Nominal heat output	kW	11,1
Thermal efficiency	%	86,6
Nominal consumption	kg/h	2,9
Weight	kg	340
Dimensions (WxDxH)	cm	100x58x147

MAIN FEATURES



GENERAL CHARACTERISTICS

- Natural convection
- Aluker fireplace
- Cast iron brazier
- Cast iron door
- Top flue outlet
- Rear flue outlet
- Removable ash box
- Air wash
- Tertiary air
- Orientable front ventilation
- External air kit
- Vacuum

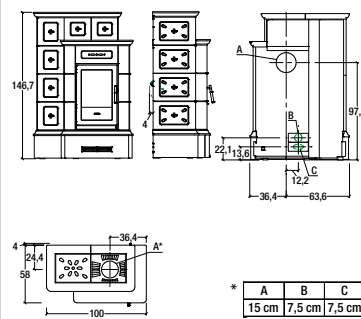

Model: ORTISEI BCS

COLORI - COLOURS - COULEURS - FARBEN - COLORES



p.118

L'originale stufa-caminetto

STUBOTTO C



Energy class		A
Type		SL150-01
Room heating capacity	m ³	185 - 315
Nominal heat output	kW	11,0
Thermal efficiency	%	80,0
Nominal consumption	kg/h	3,1
Weight	kg	312
Dimensions (WxDxH)	cm	92x58x151

MAIN FEATURES

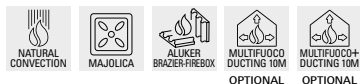

GENERAL CHARACTERISTICS

- Steel firebox
 - Aluker fireplace
 - Aluker brazier
 - Steel door
 - Top flue outlet
 - Air wash
 - Tertiary air
- OPTIONAL
- External air kit
 - Vacuum

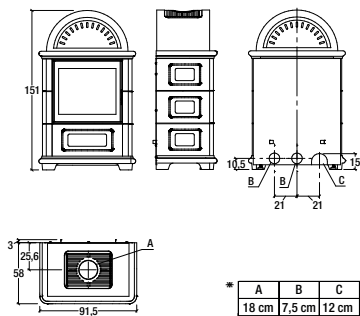

Model: STUBOTTO C

COLORI - COLOURS - COULEURS - FARBEN - COLORES



p.110

STUBOTTO C



Energy class		A
Type		SL150-01
Room heating capacity	m ³	185 - 315
Nominal heat output	kW	11,0
Thermal efficiency	%	80,0
Nominal consumption	kg/h	3,1
Weight	kg	312
Dimensions (WxDxH)	cm	92x58x151

MAIN FEATURES

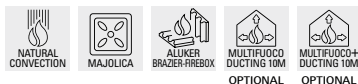

GENERAL CHARACTERISTICS

- Steel firebox
 - Aluker fireplace
 - Aluker brazier
 - Steel door
 - Top flue outlet
 - Air wash
 - Tertiary air
 - Orientable front ventilation
- OPTIONAL
- External air kit
 - Vacuum

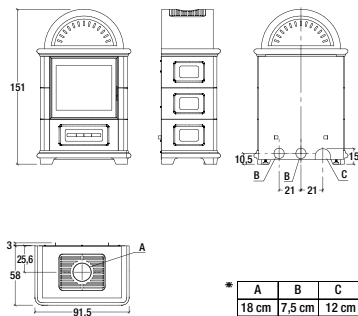

Model: STUBOTTO C

COLORI - COLOURS - COULEURS - FARBEN - COLORES



p.110

Legenda

Le caratteristiche tecniche e funzionali delle stufe Piazzetta, i loro plus di serie e gli accessori disponibili sono indicati nella legenda seguente. Scegli la stufa ideale per il tuo ambiente e le caratteristiche che soddisfano le tue necessità.

EN Key

The technical and functional characteristics of Piazzetta stoves, their standard advantages and available accessories are indicated by means of the key described below. Choose the ideal stove for your environment and the characteristics that satisfy your needs.

FR Légende

Les caractéristiques techniques et fonctionnelles des poêles Piazzetta, leurs « plus » de série et les accessoires disponibles, sont indiqués dans les légende décrites ci-après. Choisissez le poêle idéal pour votre maison et les caractéristiques aptes à satisfaire vos besoins.

DE Legende



Die technischen und funktionellen Eigenschaften der Öfen von Piazzetta, ihre Standardmerkmale und das verfügbare Zubehör sind in der nachstehenden Legende aufgeführt. Wählen Sie den Ofen, der zu Ihrem Ambiente passt und Ihre Anforderungen in jeder Hinsicht erfüllt.

ES Leyenda

Las características técnicas y funcionales de las estufas Piazzetta, sus características estándar y los accesorios disponibles, se muestran en la siguiente leyenda. Elige la estufa ideal para tu ambiente y las características que respondan a tus necesidades.

Energy class	Classe energetica	Classe énergétique	Energieeffizienzklasse	Clase de eficiencia energética
Type	Prodotto tipo	Type	Typ	Tipo
Room heating capacity	Volume riscaldabile	Volume chauffable	Raumheizvermögen	Volumen calefaccionado
Nominal heat output	Potenza termica nominale	Puissance thermique nominale	Nennwärmeleistung	Potencia térmica nominal
Thermal efficiency	Rendimento termico	Rendement thermique	Wirkungsgrad	Rendimiento térmico
Nominal consumption	Consumo nominale	Consommation nominale	Nennverbrauch	Consumo nominal
Weight	Peso della stufa	Poids du poêle	Ofengewicht	Peso de la estufa
Dimensions (WxDxH)	Dimensioni della stufa	Dimensions du poêle	Abmessungen des Holzöfen	Medidas de la estufa
Oven dimensions (WxDxH)	Dimensioni del forno	Dimensions du four	Abmessungen des Ofens	Dimensiones del horno
Dimensions with feet	Dimensioni con piedini	Dimensions avec pieds	Abmessungen mit Füßen	Dimensiones con pies

Main features

	Riscaldamento dell'ambiente a convezione naturale	Heating of the environment through natural convection	Chauffage de la pièce à convection naturelle	Raumbeheizung mit natürlicher Konvektion	Calefacción del ambiente por convección natural
	Focolare ermetico anche per case passive. Aria comburente dall'esterno	Hermetic firebox also for passive houses. Combustion air drawn from the outside	Foyer étanche pour maisons passives aussi. Air comburant de l'extérieur	Raumluftunabhängiger Feuerraum auch für Passivhäuser. Verbrennungsluft von außen	Hogar hermético incluso para casas pasivas. Aire de combustión exterior
	BCS Controllo elettronico della fiamma	BCS Electronic flame control	BCS Contrôle électronique de la flamme	BCS Elektronische Kontrolle der Flamme	BCS Control electrónico de la llama
	HSS Sistema di accumulo del calore	HSS Heat storage system	HSS Système d'accumulation de la chaleur	HSS-Wärmespeichersystem	HSS Sistema de acumulación del calor
	Sistema con aria terziaria	Tertiary air system	Système avec air tertiaire	Tertiärluftsystem	Sistema con aire terciario
	Multifuoco® System canalizzabile fino a 10 metri di distanza	Multifuoco® System ductable up to a distance of 10 metres	Multifuoco® System canalisable jusqu'à 10 mètres de distance	Multifuoco® System mit möglicher Kanalisierung bis 10 m	Multifuoco® System canalizable hasta 10 metros de distancia
	Multifuoco® System Plus canalizzabile fino a 10 metri di distanza	Multifuoco® System Plus ductable up to a distance of 10 metres	Multifuoco® System Plus canalisable jusqu'à 10 mètres de distance	Multifuoco® System Plus mit möglicher Kanalisierung bis 10 m	Multifuoco® System Plus canalizable hasta 10 metros de distancia
	Rivestimento in Maiolica	Cladding entirely made of Majolica	Habillage entièrement en Faïence	Verkleidung komplett aus Majolika	Revestimiento totalmente de Mayólica
	Rivestimento in acciaio, piano superiore con Maiolica	Steel cladding, Majolica top	Habillage en acier, panneau supérieur en Faïence	Verkleidung aus Stahl, obere Abdeckplatte aus Majolika	Revestimiento de acero, tapa superior con Mayólica
	Focolare in Aluker®	Firebox in Aluker®	Foyer en Aluker®	Heizeinsatz aus Aluker®	Hogar de Aluker®
	Focolare e Braciere in Aluker®	Firebox and Brazier in Aluker®	Foyer et Brasero en Aluker®	Heizeinsatz und Brenntopf aus Aluker®	Hogar y Brasero de Aluker®
	Focolare in Aluker® Braciere in ghisa	Firebox in Aluker® Brazier in cast iron	Foyer en Aluker® Brasero en fonte	Heizeinsatz aus Aluker®, Brenntopf aus Gusseisen	Hogar de Aluker®, Brasero de hierro fundido
	Kit per il prelievo dell'aria comburente dall'esterno	Kit for outdoor combustion air intake	Kit de prélèvement de l'air comburant à l'extérieur	Kit für die Verbrennungsluft-Zuführung von außen	Kit para toma del aire comburente del exterior
	Forno per cottura pietanze con termostato	Cooking oven with thermostat	Four de cuisson avec thermostat	Backofen zum Zubereiten von Gerichten mit Thermostat	Horno con termostato para la cocción de alimentos
	Ventilazione frontale con bocchetta orientabile	Front ventilation with orientable air vent	Ventilation frontale par grille orientable	Luftaustritt an Vorderseite mit ausrichtbarer Öffnung	Ventilación frontal con boca orientable
	Basamento rotante	Rotating base	Socle pivotant	Drehbarer Sockel	Base rodante

General characteristics

REMOVABLE ASH BOX	Cassetto cenere estraibile	Tiroir à cendres amovible	Ausziehbarer Aschekasten	Cajón de cenizas extraíble
REMOVABLE STEEL FEET Removable steel or Majolica feet	Piedini removibili in acciaio o rivestiti in Maiolica	Pieds amovibles en acier ou revêtus de faïence	Entfernbare FüÙe aus Stahl oder mit Majolika-Verkleidung	Pies desmontables de acero o revestidos de mayólica
MAJOLICA CLADDING Cladding entirely made of Majolica	Rivestimento completamente in Maiolica	Revêtement entièrement en Faïence	Verkleidung komplett aus Majolika	Revestimiento totalmente de Mayólica
AIR WASH Glass cleaning with internal air flow	Pulizia vetro con flusso d'aria interno	Nettoyage de la vitre par flux d'air intérieur	Reinigung des Glases durch inneren Luftstrom	Limpieza del vidrio con flujo de aire interno
REAR FLUE OUTLET	Scarico fumi Posteriore	Sortie des fumées par l'arrière	Rauchabzug hinten	Salida de humos posterior
TOP FLUE OUTLET	Scarico fumi Superiore	Sortie des fumées supérieure	Rauchabgang oben	Salida de humos superior
ALUKER® FIREPLACE	Focolare in Aluker®	Foyer en Aluker®	Heizeinsatz aus Aluker®	Hogar de Aluker®
CAST IRON FIREPLACE	Focolare in ghisa	Foyer en fonte	Heizeinsatz aus Gusseisen	Hogar de hierro fundido
STEEL DOOR Extra thick steel door	Porta in acciaio di elevato spessore	Porte en acier de forte épaisseur	Stahltür mit hoher Wanddicke	Puerta de acero de alto espesor
CAST IRON DOOR Extra thick cast iron door	Porta in ghisa di elevato spessore	Porte en fonte de forte épaisseur	Tür aus Gusseisen mit hoher Wanddicke	Puerta de hierro fundido de alto espesor
HUMIDIFIER Also for the use of perfumed essences	Umidificatore anche per l'impiego di fragranze profumate	Humidificateur aussi pour l'utilisation d'essences parfumées	Lufterfrischer auch für Duftessenzen	Humidificador y difusor de esencias
CAST IRON BRAZIER	Braciere in ghisa	Brasero en fonte	Brenntopf aus Gusseisen	Brasero de hierro fundido
CAST IRON / SKAMOLEX BRAZIER	Braciere in ghisa / Skamolex	Brasero en fonte / Skamolex	Brenntopf aus Gusseisen / Skamolex	Brasero de hierro fundido / Skamolex
ALUKER® BRAZIER	Braciere in Aluker®	Brasero en Aluker®	Brenntopf aus Aluker®	Brasero de Aluker®
STEEL CLADDING	Rivestimento in acciaio	Habillage en acier	Stahlverkleidung	Revestimiento de acero
HSS Heat Storage System	HSS Sistema di accumulo del calore	HSS Système d'accumulation de la chaleur	HSS-Wärmespeichersystem	HSS Sistema de acumulación del calor
VACUUM Ash vacuum cleaner for stove cleaning	Aspiracenera dedicato alla pulizia della stufa	Aspirateur de cendres pour le nettoyage du poêle	Aschesauger zur Ofenreinigung	Aspirador de cenizas dedicado a la limpieza de la estufa

General characteristics

STEEL FIREBOX	Focolare in acciaio	Foyer en acier	Brennkammer aus stahl	Hogar en acero
TERTIARY AIR Tertiary air system	Sistema con aria terziaria	Système avec air tertiaire	Tertiärluftsystem	Sistema con aire terciario
MAJOLICA TOP Top with Majolica	Piano superiore in Maiolica	Plateau supérieur avec Faïence	Obere Abdeckplatte aus Majolika	Tapa superior con Mayólica
NATURAL CONVECTION For heating also through natural convection	Per poter riscaldare anche a convezione naturale	Pour pouvoir chauffer aussi à convection naturelle	Zur Beheizung mit natürlicher Konvektion	Para poder calentar por convección natural
INOX STEEL OVEN WITH THERMOSTAT	Forno per cottura pietanze in acciaio con termostato	Four de cuisson en acier avec thermostat	Backofen zum Zubereiten von Gerichten mit Thermostat	Horno con termostato para la cocción de alimentos en acero
ORIENTABLE FRONT VENTILATION Front ventilation with orientable air vent	Ventilazione frontale con bocchetta orientabile	Ventilation frontale par grille orientable	Luftaustritt an Vorderseite mit ausrichtbarer Öffnung	Ventilación frontal con boca orientable
EXTERNAL AIR KIT Kit for outdoor combustion air intake	Kit per il prelievo dell'aria comburente dall'esterno	Kit de prélèvement de l'air comburant à l'extérieur	Kit für die Verbrennungsluft- Zuführung von außen	Kit para toma del aire comburente del exterior
ASH TRAY	Cassetto cenere	Tiroir à cendres	Aschekasten	Cajón de cenizas

Assistenza ed estensione di garanzia

ASSISTENZA SPECIALIZZATA

La tua piena soddisfazione è il nostro obiettivo primario. L'assistenza pre e post-vendita offerta da Piazzetta è garantita da personale altamente specializzato e dai nostri Centri di Assistenza Tecnica presenti in tutto il mondo.

EN Specialised support

Our main goal is your total satisfaction. The pre- and after-sales support offered by Piazzetta is guaranteed by highly specialised personnel and our technical support centres located worldwide.

FR Assistance spécialisée

Votre entière satisfaction est notre objectif principal. Le service avant et après-vente de Piazzetta est garanti par un personnel hautement spécialisé et par nos centres d'assistance technique situés dans le monde entier.

NL Gespecialiseerde bijstand

uw volledige tevredenheid is ons primaire doel. De door Piazzetta geboden pre- en aftersaleservice wordt gegarandeerd door hooggekwalificeerd personeel en door onze Technische Servicecentra over de hele wereld.



DE Spezialisierter kundendienst

Ihre volle Zufriedenheit ist unser Hauptziel. Die von Piazzetta angebotene vor und nach dem Kauf wird von hochspezialisiertem Personal und unseren technischen Kundendienstzentren auf der Unterstützung ganzen Welt gewährleistet.

ES Asistencia especializada

Tu plena satisfacción es nuestro objetivo primario. La asistencia preventiva y postventa ofrecida por Piazzetta está garantizada por personal altamente especializado y por nuestros Centros de Asistencia Técnica presentes en todo el mundo.

ESTENSIONI DI GARANZIA

Nella pagina web MyPiazzetta.com registrati a **Easy Life** ed estenderai gratuitamente la copertura di garanzia fino a 5 anni*. Nei 10 anni successivi al tuo acquisto è garantita la disponibilità di tutti i ricambi originali.

*Le condizioni contrattuali prevedono differenti periodi di copertura - Valido solo nei Paesi dell'Unione Europea.

FR Extensions de garantie

Inscrivez-vous sur MyPiazzetta.com pour bénéficier gratuitement de l'extension de garantie Easy Life jusqu'à 5 ans*. La disponibilité de toutes les pièces de rechange originales est garantie pendant 10 ans après votre achat.

*Les conditions contractuelles prévoient des périodes de couverture différentes - Valable uniquement dans les pays de l'Union européenne.

DE Garantieverlängerungen

Registrieren Sie sich auf MyPiazzetta.com zur kostenlosen Easy Life Garantieverlängerung bis zu 5 Jahre*. Bis 10 Jahre nach dem Kauf ist die Verfügbarkeit aller Original-Ersatzteile garantiert.

*Die Vertragsbedingungen sehen unterschiedliche Laufzeiten vor - Gültig nur in Ländern der Europäischen Union.

EN Warranty extensions

On the MyPiazzetta.com web page, register for Easy Life and you will extend the warranty coverage up to 5 years for free.* The availability of original spare parts is guaranteed in the ten-year period after your purchase.

*The contractual conditions include different periods of cover - Valid only in European Union countries.

NL Garantieverlenging

Registreer op de webpagina MyPiazzetta.com met Easy Life en verleng uw garantiedekking gratis tot 5 jaar.* De beschikbaarheid van alle originele reserveonderdelen wordt gedurende 10 jaar na aankoop gegarandeerd.

*De contractuele voorwaarden voorzien verschillende garantieperiodes - Alleen geldig in de landen van de Europese Unie.

ES Extensiones de garantía

En la página web MyPiazzetta.com regístrate en Easy Life y amplie la cobertura de su garantía hasta 5 años* de forma gratuita. Durante 10 años después de tu compra, se garantiza la disponibilidad de todos los recambios originales.

*Las condiciones contractuales prevén diferentes periodos de cobertura - Válido solo en los países de la Unión Europea.

EASY LIFE
PIAZZETTA

GARANZIA
WARRANTY

5

ANNI-YEARS

RICAMBI
PARTS

10

ANNI-YEARS

easylife.piazzetta.com

Index

L'ampia gamma di Prodotti Piazzetta è in grado di soddisfare tutte le necessità di impiego. Le famiglie delle stufe a legna si diversificano per modalità di impiego e per le loro performance.

EN The broad range of Piazzetta products is able to satisfy all usage requirements. The wood-burning range of stoves diversify themselves by usage and by performance.

FR La vaste gamme de Produits Piazzetta saura satisfaire tous les besoins d'emploi. Les familles des poêles à bois se diversifient pour modalité d'emploi et pour leur performance.

DE Das umfassende Produktangebot von Piazzetta ist in der Lage, sämtliche Betriebsanforderungen zu erfüllen. Die Familien der Kaminöfen sind in Bezug auf den Gebrauch und Ihrer Leistungen sehr vielfältig.

ES La amplia gama de productos Piazzetta responde a todas las necesidades de uso. Las familias de estufas de leña se diversifican por tipo de uso y por su rendimiento.

	Prod.	Tech.
MODELS		
BONNY	p.96	p.148
CIRCLE	p.46	p.148
E900 M	p.128	p.149
E911	p.126	p.149
E924	p.40	p.150
E924 A.	p.48	p.150
E924 A-H.	p.50	p.151
E924 H.	p.42	p.152
E924 M	p.44	p.152
E928	p.84	p.153
N E928 Steel	p.76	p.154
E928 A.	p.90	p.154
E928 C.	p.78	p.155
E928 C-H.	p.82	p.156
E928 C-M	p.80	p.157
E928 H.	p.88	p.159
E928 M	p.86	p.159
N E928 R.	p.74	p.160
E928 S.	p.92	p.160
E929 C.	p.70	p.161
E929 C-H.	p.72	p.162
E929 D.	p.54	p.164
E929 D-H.	p.56	p.164
E929 M	p.58	p.165
E929 M-H	p.60	p.166
E929 T.	p.62	p.166
QUBE 1	p.100	p.169
QUBE 2	p.102	p.170
QUBE 3	p.104	p.170
QUBE 4	p.106	p.170
ROUND	p.64	p.167
ROUND-H.	p.68	p.168
ROUND-M	p.66	p.168
THELMA	p.98	p.171

	Prod.	Tech.
TREND LINE		
E124	p.132	p.172
E124 A.	p.134	p.172
E128	p.136	p.173
E128 A.	p.138	p.174
E129 M	p.140	p.176
STUBOTTI e STUFE CAMINETTO		
BERNA	p.114	p.178
BRUNICO	p.120	p.186
CANAZEI	p.122	p.186
DAVOS	p.112	p.180
LUGANO	p.116	p.183
ORTISEI	p.118	p.187
STUBOTTO C.	p.110	p.188

N = NEW

Copyright © 2022. Tutti i diritti sul catalogo, sulle immagini ed i testi, marchi e segni distintivi sono riservati e di proprietà di Gruppo Piazzetta S.p.A. Sono vietate la riproduzione e diffusione, anche parziale, in qualsiasi forma, e/o l'uso non autorizzato. L'azienda ha facoltà, nel perfezionare i prodotti, di variare le caratteristiche tecniche ed estetiche. I modelli possono variare da Paese a Paese.

EN Copyright © 2022. All rights of the catalog, images and texts, trademarks and distinctive labels are reserved and owned by Gruppo Piazzetta S.p.A. Reproduction and distribution, in whole or in part, in any form, and / or unauthorized use are prohibited. The company has the faculty, in perfecting the products, to vary the technical and design characteristics. Models may vary from country to country.

FR Copyright © 2022. Tous les droits sur le catalogue, sur les images et les textes, marques et signes distinctifs sont réservés et sont la propriété du Gruppo Piazzetta s.p.a. La reproduction et la diffusion, même partielle, sous quelque forme, et/ou l'utilisation sans autorisation sont interdits. La société peut, dans le perfectionnement des produits, en modifier les caractéristiques techniques et esthétiques. Les modèles peuvent être différents selon les pays.

DE Copyright © 2022. Alle Rechte an den Katalog, auf Bilder und Texte, Marken und Kennzeichen sind vertraulich und von Gruppo Piazzetta s.p.a. unternehmensintern reserviert. Die Vervielfältigung und Verbreitung, auch nur teilweise, in irgendeiner Form und/oder unberechtigte Verwendung sind unzulässig. Das Unternehmen hat die Möglichkeit bei Produktverbesserungen technische und ästhetische Eigenschaften zu ändern. Die Modelle können von Land zu Land unterschiedlich sein.

ES Copyright © 2022. Todos los derechos sobre el catálogo, imágenes y textos, marcas comerciales y logotipos son propiedad del Gruppo Piazzetta s.p.a. Queda prohibida la reproducción y la difusión, incluso parcial, de cualquier forma, y / o uso no autorizado. La empresa puede, en el perfeccionamiento de los productos, modificar las características técnicas y estéticas sin previo aviso. Los modelos pueden variar de un país a otro.



Il borgo di Asolo e la sua Rocca - The village of Asolo and its fortress



HQ e produzione ad Asolo TV Italy - HQ and production in Asolo TV Italy



Sixty Years of Fire Burning Inside



GRUPPO  PIAZZETTA

Via Montello, 22 - 31011 Asolo (TV) Italy
tel. +39 0423 5271 - fax +39 0423 55178
www.piazzetta.com - info@piazzetta.com
☎ 800-842026



ISO 9001 - 9190.GPIA

Focolari

Fireboxes - Monoblocs - Haarden

Heizeinsätze - Monobloque



Index

P.2	Piazzetta Total Comfort
P.4	Passione Accesa da oltre 60 anni
P.6	Prodotti fatti per durare nel tempo
P.8	Abbinamenti
P.10	Rivestimenti in Maiolica
P.12	Tecnologia: i focolari
P.16	Combustibili
P.20	Multifuoco® System
P.28	Caratteristiche
P.34	Focolari
P.90	Thermo Solutions
P.98	Tabelle di compatibilità
P.101	Accessori a richiesta
P.107	Legenda
P.115	Assistenza e Garanzia
P.116	Index

FR

P.2	Piazzetta Total Comfort
P.4	Passion enflammée depuis plus de 60 ans
P.6	Des produits faits pour durer dans le temps
P.8	Associations
P.10	Revêtements en majolique
P.12	Technologie : les monoblocs
P.16	Combustibles
P.20	Multifuoco® System
P.28	Caractéristiques
P.34	Monoblocs
P.90	Thermo Solutions
P.98	Tableaux de compatibilité
P.101	Accessoires sur demande
P.107	Légende
P.115	Service et garantie
P.116	Index

DE

P.2	Piazzetta Total Comfort
P.4	Brennendes Feuer seit über 60 Jahren
P.6	Produkte, die Jahrzehnte überdauern
P.8	Kombinationen
P.10	Majolika-Verkleidung
P.12	Technologie: Heizeinsätze
P.16	Brennstoffe
P.20	Multifuoco® System
P.28	Eigenschaften
P.34	Heizeinsätze
P.90	Thermo Solutions
P.98	Kompatibilitätstabellen
P.101	Zubehör auf Anfrage
P.107	Legende
P.115	Kundendienst und Garantie
P.116	Index

EN

Piazzetta Total Comfort
A burning passion for over 60 years
Products that endure time
Combinations
Majolica Surrounds
Technology: fireboxes
Fuels
Multifuoco® System
Characteristics
Fireboxes
Thermo Solutions
Compatibility tables
Accessories on request
Key
Support and Warranty
Index

NL

Piazzetta Total Comfort
Al meer dan 60 jaar een brandende passie
Producten die gemaakt zijn om lang mee te gaan
Combinaties
Majolica bekleding
Technologie: de vuurhaarden
Brandstoffen
Multifuoco® System
Kenmerken
Vuurhaarden
Thermo Solutions
Compatibiliteitstabellen
Accessoires op aanvraag
Legende
Service en Garantie
Index

ES

Piazzetta Total Comfort
Pasión encendida desde hace más de 60 años
Productos hechos para durar a lo largo del tiempo
Combinaciones
Revestimientos en Mayólica
Tecnología: monobloques
Combustibles
Multifuoco® System
Características
Monobloques
Thermo Solutions
Tablas de compatibilidad
Accesorios a petición del cliente
Leyenda
Servicio y garantía
Index

L'azienda ha facoltà, nel perfezionare i prodotti, di variare le caratteristiche tecniche ed estetiche. I modelli possono variare da Paese a Paese.

EN The company has the faculty, in perfecting the products, to vary the technical and design characteristics. Models may vary from country to country.

FR La société peut, dans le perfectionnement des produits, en modifier les caractéristiques techniques et esthétiques. Les modèles peuvent être différents selon les pays.

NL Het bedrijf heeft het recht om bij het perfectioneren van zijn producten de technische en esthetische kenmerken te wijzigen. De modellen kunnen van land tot land verschillen.

DE Das Unternehmen hat die Möglichkeit bei Produktverbesserungen technische und ästhetische Eigenschaften zu ändern. Die Modelle können von Land zu Land unterschiedlich sein.

ES La empresa puede, en el perfeccionamiento de los productos, modificar las características técnicas y estéticas sin previo aviso. Los modelos pueden variar de un país a otro.

Idee intorno al fuoco

Realizzare soluzioni innovative di riscaldamento, unire qualità ed estetica, sviluppando intorno al fuoco nuove idee ed atmosfere per farne il vero centro della casa: questo è l'impegno di Piazzetta.

EN Ideas around the fire

Create innovative heating solutions, merging quality and aesthetics, develop new ideas and atmospheres around fire to make it the fulcrum of the home: these are the objectives that Piazzetta pursues.



FR Des idées autour du feu

Réaliser des solutions innovantes, allier la qualité à l'esthétique, développer de nouvelles idées autour du feu et créer la juste atmosphère pour le mettre au cœur de la maison : c'est là l'engagement de Piazzetta.

NL Ideeën rond het vuur

Innovatieve verwarmingsooplossingen realiseren, kwaliteit en esthetiek combineren, nieuwe ideeën en sferen ontwikkelen rond het vuur om dit tot het middelpunt van de woning te maken: dat is waar Piazzetta naar streeft.

DE Ideen rund ums Feuer

Innovative Heizlösungen realisieren, Qualität und Ästhetik miteinander verbinden, neue Ideen und Atmosphären rund ums Feuer entwickeln, um es zum Mittelpunkt des eigenen Heims werden zu lassen: Dafür steht Piazzetta.

ES Ideas alrededor del fuego

Realizar soluciones innovadoras de calefacción, unir la calidad a la estética, desarrollando alrededor del fuego nuevas ideas y atmósferas para convertirlas en el verdadero centro de la casa: es el compromiso de Piazzetta.

Piazzetta Total Comfort

Scegli tra la più ampia gamma di caminetti e stufe a legna, pellet, gas. Stile, design, tecnologia, qualità dei prodotti e la ricercatezza dei particolari tutta italiana. Un mondo di certezze sul quale contare, anche grazie alla professionalità dei centri di assistenza tecnica Piazzetta sul territorio. Professionisti a tua disposizione formati dall'Azienda, sempre aggiornati e disponibili.

EN Choose among the widest range of wood, pellet and gas burning stoves and fireplaces. Distinctly Italian in style, design, technology product quality and refined details. A world of certainties which you can rely on thanks to the expertise available through Piazzetta trained service centres. Up-to-date professionals willing to assist you.

FR Choisissez parmi la plus riche gamme de cheminées et poêles à bois, pellet ou gaz. Style, design, technologie, qualité des produits et raffinement des détails typiquement italien. Un monde de certitudes sur lequel compter, grâce au professionnalisme des Service après vente Piazzetta, formés par notre entreprise et toujours disponibles.



NL Kies uit het meest uitgebreide gamma van open haarden en hout-, pellet- en gaskachels. Stijl, design, technologie, kwaliteit en de typisch Italiaanse verfijning in de details. Een wereld van zekerheid waar u op kunt rekenen, mede dankzij de professionaliteit van de technische assistentiecentra van Piazzetta ter plaatse. Binnen het bedrijf opgeleide professionals staan tot uw beschikking.

DE Wählen Sie aus dem größten Angebot an Kaminen und Öfen mit Holz-, Pellet- oder Gasfeuerung das für Sie passende Modell aus. Stil, Design, Technologie, Produktqualität und raffinierte Detailauswahl auf Italienisch. Eine Welt sicherer Werte, auf die Sie zählen können. Auch dank des regionalen, professionellen Techn. Kundendienstes mit von Piazzetta aus- und weitergebildeten Fachkräften.

ES Elige entre la más amplia gama de chimeneas y estufas de leña, pellets, gas. Estilo, diseño, tecnología, calidad de producto, detalles refinados puramente italianos. Un mundo de certezas con las que contar, incluso por la profesionalidad de los centros de asistencia técnica Piazzetta. Profesionales a tu disposición, siempre informados, capacitados por la empresa.

Passione Accesa da oltre 60 anni

La nostra è una passione artigiana tutta italiana, dove estetica e tecnologia si uniscono per creare elementi di arredo protagonisti del vivere moderno. Da sempre ricerchiamo e progettiamo in Italia, ad Asolo, soluzioni esclusive, offriamo in ogni nostro prodotto i massimi standard di efficienza, praticità, sicurezza, con un design ed una qualità dei materiali e delle lavorazioni che ci contraddistinguono.

EN A burning passion for over 60 years.
Genuine Italian artisan passion merging aesthetics and technology to create furnishing elements that exemplify modern day living. Our Italian cultural roots have always been based in Asolo where we set our goals to achieve the highest standards in efficiency, practicality and the utmost in safety in each of our products which reflect our unique characteristic of design and quality.



1 9 6 0 - 2 0 2 0

FR **Passion enflammée depuis plus de 60 ans**

Notre passion est une passion artisanale 100% italienne où esthétique et technologie donnent vie à des éléments véritables acteurs de la vie contemporaine. C'est en Italie, à Asolo que nous recherchons et concevons depuis toujours des solutions exclusives. Nous offrons à travers chacun de nos produits les plus hauts standards de rendement, confort d'utilisation et sécurité, avec un design et une qualité des matériaux et des réalisations qui nous caractérisent.

NL **Al meer dan 60 jaar een brandende passie.**

Een typisch Italiaanse passie voor vakmanschap, waarin esthetiek en technologie samengaan om woninginrichtingselementen te creëren die een hoofdrol spelen in het moderne wonen. In Asolo in Italië onderzoeken en ontwerpen wij van oudsher exclusieve oplossingen, bieden wij in al onze producten maximale efficiëntie, gebruiksvriendelijkheid en veiligheid, met het voor ons kenmerkende design en materialen en afwerkingen van de hoogste kwaliteit.

DE **Brennendes Feuer seit über 60 Jahren.**

Unser Handwerk leben wir mit italienischer Leidenschaft und als gelungene Verknüpfung von Ästhetik und Technologie zur Herstellung von Einrichtungsgegenständen, die zu Protagonisten modernen Wohnens geworden sind. Seit der Gründung unserer Firma forschen und entwickeln wir im norditalienischen Asolo, um exklusive Lösungen, hohe Benutzerfreundlichkeit, Sicherheit, erlesenes Design und beste Qualität zu liefern.

ES **Pasión encendida desde hace más de 60 años**

La nuestra es una pasión artesanal totalmente italiana, donde la estética y la tecnología se unen para crear elementos de decoración protagonistas del vivir moderno. En Asolo, Italia, concebimos y diseñamos soluciones exclusivas, ofrecemos en cada producto los máximos estándares de eficiencia, practicidad, seguridad, con un diseño y una calidad de material y elaboración que nos distingue.



Prodotti fatti per durare nel tempo

La solidità dei nostri prodotti è fatta di tanta esperienza e continua ricerca. Dalla selezione delle materie prime alle singole fasi di lavorazione, tutto viene controllato nei minimi dettagli da personale specializzato. Nei nostri laboratori si sviluppa il prodotto e viene testata la produzione e la rispondenza alle normative internazionali. I caminetti Piazzetta mantengono le loro caratteristiche nel tempo, per questo offriamo una estensione gratuita della garanzia per 5 anni.

FR Des produits faits pour durer dans le temps

Nos produits doivent leur solidité à notre bagage d'expérience et à notre travail de recherche continue. Du choix des matières premières aux nombreuses phases de réalisation, tout est contrôlé dans le moindre détail par notre personnel spécialisé. Nos ateliers développent le produit et font des essais sur la production et sur sa conformité aux normes internationales. Les cheminées Piazzetta conservent leurs caractéristiques au long des années, c'est d'ailleurs pour cette raison que nous offrons une extension de garantie de 5 ans.

DE Produkte, die Jahrzehnte überdauern.

Die solide Struktur unserer Produkte basiert auf langjähriger Erfahrung und kontinuierlicher Forschung. Von der Auswahl der Rohstoffe bis zu den einzelnen Bearbeitungsphasen wird alles bis ins kleinste Detail von spezialisierten Fachkräften kontrolliert. Unsere Labors entwickeln das Produkt, testen die Produktion und prüfen das Resultat mit den Vorgaben internationaler Normen. Die Kamine von Piazzetta behalten ihre Wertigkeit über lange Zeit, weshalb wir bei der Brennkammer eine kostenlose Erweiterung der Garantie auf über 5 Jahre gewährleisten können.

EN Products that endure time.

The sturdiness of our products stems from extensive experience and on-going research. Starting from the selection of raw materials to every single processing phase, everything is checked right down to the slightest detail by our specialized personnel. In our laboratories the products are tested for their conformity to international regulations Piazzetta fireplaces retain their characteristic over time: this is why we offer a free 5 years warranty extension.

NL Producten die gemaakt zijn om lang mee te gaan.

De duurzaamheid van onze producten komt voort uit jarenlange ervaring en voortdurend onderzoek. Van de keuze van de grondstoffen tot elke afzonderlijke productiefase: alles wordt tot in detail gecontroleerd door gespecialiseerd personeel. In onze laboratoria wordt het product ontwikkeld en wordt de productie en de naleving van internationale normen getest. De haarden van Piazzetta behouden hun kenmerken door de tijd; daarom bieden wij een gratis verlengde garantie van 5 jaar op onze producten.

ES Productos hechos para durar a lo largo del tiempo

La solidez de nuestros productos está hecha de mucha experiencia y de continuos estudios. Desde la selección de las materias primas hasta las fases de elaboración, todo es detalladamente controlado por personal especializado. En nuestros talleres se desarrolla el producto, se verifica la producción y se comprueba la conformidad con las normas internacionales. Las chimeneas Piazzetta mantienen sus características a lo largo del tiempo. Por eso ofrecemos gratuitamente una extensión de 5 años de la garantía.

EASY LIFE
PIAZZETTA

GARANZIA
WARRANTY

5

ANNI-YEARS

RICAMBI
PARTS

10

ANNI-YEARS

easylife.piazzetta.com

Certificazioni e Associazioni

- EN** Certifications and Associations
- FR** Certifications et Associations
- NL** Certificaten en Verenigingen
- DE** Zertifizierungen und Vereinigungen
- ES** Certificaciones y Asociaciones



ISO 9001 - 9190.GPIA





Abbinamenti

Combinations
Associations
Combinaties
Kombinationen
Combinaciones

Per il vasto assortimento di focolari a legna o pellet, che possono riscaldare ambienti di differenti dimensioni, sono disponibili esclusivi rivestimenti artigianali, per sofisticati abbinamenti di stile.

EN For the vast assortment of wood or pellet fireplaces, which heat rooms of different sizes, exclusive handcrafted coverings are available, for sophisticated style combinations.

FR Pour le vaste assortiment de cheminées à bois ou à granulés, qui peuvent chauffer différentes pièces, sont disponibles des revêtements exclusifs fabriqués à la main, pour des combinaisons de style sophistiquées.

NL Voor het uitgebreide assortiment hout- of pelletkachels, die kamers van verschillende afmetingen kunnen verwarmen, zijn exclusieve handgemaakte bekledingen beschikbaar voor verfijnde stijcombinaties.

DE Für die große Auswahl an Holz- oder Pelletkaminen, mit denen Räume unterschiedlicher Größe beheizt werden können, stehen exklusive handgefertigte Verkleidungen für raffinierte Stilkombinationen zur Verfügung.

ES Para la amplia gama de hogares de leña o pellet, capaces de calentar ambientes de medidas diferentes, están disponibles exclusivos revestimientos artesanales, para sofisticadas combinaciones de estilo.

Rivestimento - Surround



Combustibile - Fuel



Riscaldamento - Heating



VERSIONI A CONVEZIONE NATURALE



L'esclusivo piacere del fuoco a legna dei caminetti Piazzetta può essere apprezzato nella collezione / Veneziani anche con il sistema di riscaldamento a convezione naturale.

FR Versions à convection naturelle
Le plaisir unique du feu de bois des cheminées Piazzetta peut être apprécié grâce à la collection / Veneziani, également disponible avec le système de chauffage à convection naturelle.

DE Versionen mit Naturkonvektion
Das exklusive Vergnügen des Holzfeuers der Piazzetta Kamine kann bei der Kollektion / Veneziani auch mit Naturkonvektions-Heizsystem genossen werden.

EN Natural convection versions
Relish the exclusive pleasure of a wood fire in Piazzetta fireplaces through the / Veneziani collection also with the natural convection heating system.

NL Uitvoeringen met natuurlijke convectie
Het exclusieve plezier van een houtvuur in de haarden van Piazzetta kan in de collectie / Veneziani ook worden genoten met het verwarmings-systeem met natuurlijke convectie.

ES Versiones de convección natural
El exclusivo placer del fuego de leña de las chimeneas Piazzetta puede apreciarse en la colección / Veneziani también con el sistema de calefacción por convección natural.



VERSIONI MULTIFUOCO® SYSTEM



Di serie nelle versioni a pellet, disponibili come optional nelle versioni a legna, il sistema di ventilazione forzata Multifuoco® garantisce un riscaldamento uniforme.

FR Versions Multifuoco® System
Présent de série dans les versions à granulés, disponible en option dans les versions à bois, le système de ventilation forcée Multifuoco® garantit un chauffage uniforme.

DE Versionen mit Multifuoco® System
Bei den Pelletversionen serienmäßig und bei den Holzversionen als Extra erhältlich, sorgt das Gebläselüftungssystem Multifuoco® für einheitliche Beheizung.

EN Multifuoco® System versions
A standard feature on pellet-burning versions and optional on wood-burning versions, the Multifuoco® forced ventilation system guarantees uniform heating.

NL Uitvoeringen met Multifuoco®
Het Multifuoco®-systeem met geforceerde ventilatie, standaard aanwezig op de pellet-uitvoeringen en als optie verkrijgbaar op de hout-uitvoeringen, garandeert een gelijkmatige verwarming.

ES Versiones Multifuoco® System
De serie en las versiones de pellets, disponible con accesorio opcional en las versiones de leña, el sistema de ventilación forzada Multifuoco® garantiza una calefacción uniforme.



VERSIONI THERMO



Dal piacere della fiamma di un caminetto a pellet è possibile ricavare anche il calore per alimentare il riscaldamento tradizionale a termosifoni o a pavimento.

FR Versions Thermo
Outre le plaisir de la flamme d'une cheminée à granulés, il est aussi possible d'exploiter la chaleur pour alimenter un système de chauffage traditionnel à radiateurs ou au sol.

DE Thermo-Versionen
Das Feuer in einem Pelletkamin ist nicht nur ein Genuss, sondern kann auch Wärme für die herkömmliche Heizung mit Heizkörpern oder Fußbodenheizungen liefern.

EN Thermo versions
Besides the pleasure it affords, the flame of pellet-burning fireplaces can also generate heat for running traditional radiator-based or underfloor heating systems.

NL Thermo-uitvoeringen
Naast de aangename sfeer van de vlammen in een open haard of op pellets kan de warmte ook gebruikt worden als voeding voor traditionele of vloerverwarming.

ES Versiones Thermo
Del placer de la llama de un chimenea de pellets se puede obtener también el calor para alimentar la calefacción tradicional con radiadores o de suelo.



Rivestimenti in Maiolica

Rivestimenti esclusivi, originali ed unici, per valorizzare e custodire il fuoco. Realizzati in pregiata Maiolica sono espressione di creatività e passione, arricchendo con uno stile unico l'ambiente nel quale sono inseriti. L'arte della lavorazione artigianale della Maiolica ci consente di realizzare rivestimenti in grande formato in oltre 40 colori e differenti finiture che trasformano il caminetto in un elemento di design, vero protagonista dello stile della casa.

FR Revêtements en majolique

Revêtements exclusifs, originaux et uniques, pour protéger et de valoriser le feu. Fabriqués en majolique fine, ils sont une expression de créativité et de passion, enrichissant l'environnement dans lequel ils sont insérés avec un style unique. L'art du travail artisanal de la majolique nous permet de créer des revêtements de grand format dans plus de 40 couleurs et différentes finitions qui transforment la cheminée en un élément de design, véritable protagoniste du style de la maison.

DE Majolika-Verkleidung

Exklusive, originelle und einzigartige Verkleidungen um das Feuer zu valorisieren und zu schützen. Sie bestehen aus feiner Majolika und sind Ausdruck von Kreativität und Leidenschaft. Sie bereichern den Wohnbereich in dem sie eingesetzt werden, mit einem einzigartigen Stil. Die Handwerkskunst unserer Majolika ermöglicht es uns, großformatige Verkleidungen in über 40 Farben und verschiedenen Verarbeitungen herzustellen, die den Kamin in ein Designelement verwandeln, den wahren Protagonisten vom Stil des Hauses.

EN Majolica Surrounds

Exclusive, original and unique surrounds, to enhance and accompany the fire. Made of fine Majolica, they are an expression of creativity and passion, enriching the environment in which they are part of, with a unique style. The art of majolica artisanship allows us to create large one of kind pieces, in over 40 colors and different finishes that transform the fireplace into a design element, the true style protagonist of any home.

NL Majolica bekleding

Exclusieve, originele en unieke bekledingen om het vuur te versterken en te beschermen. Ze zijn gemaakt van fijne Majolica en zijn een uitdrukking van creativiteit en passie. Ze verrijken ook de omgeving waarin ze worden opgenomen met een unieke stijl. De kunst van majolica-vakmanschap stelt ons in staat om grootformaat bekledingen te creëren in meer dan 40 kleuren en verschillende afwerkingen. Ze toveren de haard om tot een designelement, de ware hoofdrolspeler van de stijl van het huis.

ES Revestimientos en Mayólica

Revestimientos exclusivos, originales y únicos, para resaltar y conservar el fuego. Realizados en preciosa Mayólica son expresión de creatividad y pasión, enriqueciendo con un estilo único el ambiente donde están instalados. El arte de la elaboración artesanal de la Mayólica nos permite realizar revestimientos de grandes dimensiones en más de 40 colores y diferentes acabados que transforman la chimenea en un elemento de design, verdadero protagonista del estilo de la casa.



Tecnologia: i focolari

Technology: fireboxes
Technologie : les monoblocs
Technologie: de vuurhaarden
Technologie: Heizeinsätze
Tecnología: monobloques

Il comfort ed il calore che solo un caminetto Piazzetta è in grado di offrire vengono garantiti dall'accurata progettazione e realizzazione del focolare a legna o pellet. Scegliere un focolare Piazzetta significa contare su una sicurezza certificata, facilità di utilizzo, semplicità di installazione, ridotta manutenzione, ed elevata efficienza. Significa garantirsi le migliori performance, con un costante risparmio nell'impiego, scegliendo tra un'ampia gamma di soluzioni e sistemi di riscaldamento, per il singolo ambiente o l'intera casa, a convezione naturale, Multifuoco® o con focolari Thermo.

EN The comfort and heat that only a Piazzetta fireplace can offer stem from the careful design and construction of the wood-burning or pellet-burning firebox. Choosing a Piazzetta firebox means relying on certified safety, ease of use, straightforward installation, low maintenance and high efficiency. It also entails optimal performances that are always cost-efficient, thanks to a broad range of heating solutions and systems, for single rooms or the entire home, based on natural convection, Multifuoco® systems or Thermo fireboxes.

FR Le confort et la chaleur que seule une cheminée Piazzetta peut vous offrir sont garantis par la conception et la réalisation soignées du foyer à bois ou à granulés. Choisir un foyer Piazzetta, c'est pouvoir bénéficier des garanties suivantes : sécurité certifiée, facilité d'utilisation, simplicité d'installation, entretien réduit et haute efficacité. C'est pouvoir compter sur les meilleures performances tout en économisant constamment, en faisant son choix parmi une large gamme de solutions et systèmes de chauffage, pour une seule pièce ou pour toute la maison, à convection naturelle, Multifuoco® ou avec un foyer Thermo.

NL Het comfort en de warmte die alleen een open haard van Piazzetta kan bieden, worden gegarandeerd door het nauwkeurige ontwerp en realisatie van de vuurhaard op hout of op pellets. Kiezen voor een vuurhaard van Piazzetta betekent kunnen rekenen op een gecertificeerde veiligheid, gebruiksgemak, een eenvoudige installatie, beperkt onderhoud en een hoge efficiëntie. Het betekent de garantie van de beste prestaties met een constante besparing in het gebruik door te kiezen uit een breed aanbod aan verwarmingsopties en -systemen, voor één ruimte of voor de hele woning, met natuurlijke convectie, Multifuoco® of Thermo-vuurhaarden.

DE Komfort und Wärme, wie sie nur ein Piazzetta Kamin bieten kann, sind durch akkurate Planung und Ausführung des Holz- oder Pellet-Feuerraums gewährleistet. Einen Piazzetta Feuerraum zu wählen bedeutet, auf zertifizierte Sicherheit, einfache Benutzung, einfache Installation, geringen Wartungsaufwand und hohe Effizienz zählen zu können. Es bedeutet, sich beste Leistungen mit dauerhafter Ersparnis im Einsatz zu sichern und dabei aus einer breiten Palette an Heizlösungen und -systemen zu wählen, für einzelne Räume oder die gesamte Wohnung, mit Naturkonvektion, Multifuoco® oder mit Thermo-Feuerräumen.

ES El confort y el calor que solo una chimenea Piazzetta puede ofrecer se garantizan gracias al esmerado diseño y a la realización del hogar de leña o pellets. Elegir un hogar Piazzetta significa contar con una seguridad certificada, facilidad de uso, sencillez de instalación, bajo mantenimiento y alta eficiencia. Significa garantizarse las mejores prestaciones, con un ahorro constante en el uso, eligiendo entre una amplia gama de soluciones y sistemas de calefacción, para un ambiente preciso o para la vivienda entera, por convección natural, Multifuoco® o con los hogares Thermo.



ALUKER® ALTE PRESTAZIONI

Esclusivo materiale ceramico refrattario brevettato da Piazzetta, che migliora la combustione e la diffusione del calore. Consente un accumulo di energia e resiste a temperature straordinarie.

EN Aluker® High Performance

An exclusive refractory ceramic material patented by Piazzetta that improves combustion and heat diffusion. It allows for storing energy and withstands extreme temperatures.

FR Les hautes performances de l'Aluker®

Matériau céramique réfractaire exclusif breveté par Piazzetta, l'Aluker améliore la combustion et la diffusion de la chaleur. Il permet l'accumulation de l'énergie et résiste à des températures exceptionnelles.

NL Hoge prestaties van Aluker®

Een exclusief refractair keramisch materiaal, gepatenteerd door Piazzetta, dat de verbranding en de verspreiding van de warmte verbetert. Maakt opslag van energie mogelijk en is bestand tegen zeer hoge temperaturen.

DE Aluker® - Hohe Leistungen

Exklusives, von Piazzetta patentiertes feuerfestes Material, das die Verbrennung und Wärmeverteilung verbessert. Es speichert Energie und ist außerordentlich hitzebeständig.

ES Aluker® de altas prestaciones

Exclusivo material cerámico refractario patentado por Piazzetta, que mejora la combustión y la difusión del calor. Hace posible la acumulación de energía y presenta extraordinaria resistencia a las altas temperaturas.

HI-TECH DETAILS

Le soluzioni progettuali e gli accorgimenti costruttivi adottati fanno di ogni focolare Piazzetta un prodotto tecnologicamente all'avanguardia, realizzato con materiali innovativi di prima qualità.

EN Hi-Tech Details

The design solutions and construction features adopted turn each Piazzetta fireplace into a technologically advanced product made with innovative, premium-quality materials.

FR Détails Hi-Tech

Les solutions de conception et de fabrication adoptées font de chaque foyer Piazzetta un produit à l'avant-garde de la technologie, réalisé avec des matériaux innovants de première qualité.

NL High-tech details

De gebruikte ontwerp oplossingen en constructiekenmerken maken van elke Piazzetta-vuurhaard een technologisch geavanceerd product, dat gemaakt is met eersteklas innovatieve materialen.

DE Hi-Tech-Details

Die Planungslösungen und die eingesetzten konstruktiven Maßnahmen machen aus jedem Piazzetta Feuerraum ein technologisches Spitzenprodukt aus innovativen Materialien erster Güteklasse.

ES Detalles altamente tecnológicos

Las soluciones de diseño y las técnicas de fabricación adoptadas hacen de cada hogar Piazzetta un producto de vanguardia tecnológica, realizado con materiales innovadores de primera calidad.

PERFORMANCE

L'ampia gamma di focolari Piazzetta consente di trovare il prodotto migliore per realizzare il proprio esclusivo caminetto. Concepiti per garantire tutto il piacere del fuoco, offrono la massima efficienza.

EN Performance

Thanks to the wide range of Piazzetta fireboxes, you can find the best product to create your own exclusive fireplace. Designed to enhance the pleasure of fire, they offer the highest level of efficiency.

FR Performances

La large gamme de foyers Piazzetta permet de trouver le produit idéal pour réaliser sa propre cheminée unique. Conçus pour garantir tout le plaisir du feu, ils offrent une efficacité maximale.

NL Prestaties

Dankzij het brede aanbod van Piazzetta-vuurhaarden kunt u het beste product vinden voor het realiseren van uw eigen exclusieve open haard. Ontwikkeld om te genieten van het vuur met maximale energie-efficiëntie.

DE Leistungsfähigkeit

In der großen Auswahl an Piazzetta Feuerräumen finden Sie das beste Produkt für Ihren exklusiven Kamin. Konzipiert für den uneingeschränkten Genuss des Feuers, bieten sie maximale Effizienz.

ES Prestaciones

La amplia gama de hogares Piazzetta permite hallar el producto ideal para realizar una chimenea exclusiva. Concebidos para garantizar todo el placer del fuego, ofrecen la máxima eficiencia.

Rivestimenti



Fox



Mood



Fox 1



Combustibili

Fuels
Combustibles
Brandstoffen
Brennstoffe
Combustibles

La legna

La legna è il combustibile naturale per eccellenza, da sempre fonte primaria per riscaldare e per cucinare. Attorno al fuoco della legna ritroviamo gesti ed emozioni che arrivano dalla storia dell'uomo. La legna da ardere proviene principalmente dall'attività forestale controllata. Accogliere in casa un caminetto a legna significa continuare a coltivare il piacere dello stare insieme.



EN Wood

Wood is the quintessential natural fuel and has always been a primary source for heating and cooking. Gathering around a wood fire arouses age-old gestures and feelings. Wood fuel comes mainly from monitored forests. Having a wood-burning fireplace at home rekindles the pleasure of sharing pleasant moments together.

FR Le bois

Le bois est depuis toujours le combustible naturel utilisé pour le chauffage et la cuisine. Autour du feu de bois, nous retrouvons des gestes et des émotions qui remontent à l'aube de notre histoire. Le bois de chauffage provient principalement de l'activité forestière contrôlée. Avoir chez soi une cheminée à bois, c'est continuer de cultiver le plaisir d'être ensemble.

NL Hout

Hout is de natuurlijke brandstof bij uitstek, van oudsher onze primaire bron voor verwarming en het bereiden van voedsel. Rond het houtvuur vinden we gebaren en emoties die teruggaan tot het begin der tijden. Brandhout is voornamelijk afkomstig uit gecontroleerde bosbouw. Een houthaard in huis hebben betekent blijven genieten van het samenzijn rond het vuur.

DE Holz

Holz ist ein hervorragender natürlicher Brennstoff, der schon immer zum Heizen und Kochen verwendet wurde. Am Feuer begegnen wir Gesten und Emotionen, die aus der Menschheitsgeschichte hervorgehen. Brennholz stammt hauptsächlich aus der kontrollierten Forstwirtschaft. Wer sich einen Kamin mit Holzfeuerung ins Haus holt, pflegt das gesellige Beisammensein.

ES La leña

La leña es el combustible natural por excelencia; fuente primaria sempiterna para calentar y cocinar. En torno al fuego de leña se producen sensaciones y emociones perpetuadas a lo largo de la historia del hombre. La leña proviene principalmente de explotación forestal controlada. Acoger en casa una chimenea de leña significa seguir cultivando el placer de estar juntos.

Il pellet

L'impiego del pellet, combustibile ecologico da fonti rinnovabili, dall'ottima resa termica, facile da reperire e da gestire nel trasporto e nello stoccaggio, consente un sensibile risparmio in confronto ad altre fonti combustibili, nel pieno rispetto del ciclo naturale. La sua praticità d'uso ne ha garantito la diffusione.



EN Pellets

The use of pellets – an eco-friendly renewable fuel with excellent heat output that is readily available and easy to store and transport – ensures considerable cost savings compared to other fuels and fully respects the natural cycle. Its practicality makes it very widespread.

FR Les granulés

L'utilisation des granulés, combustible écologique renouvelable, à l'excellent rendement thermique, facile à trouver et à gérer au niveau transport et stockage, permet de réaliser des économies sensibles par rapport à d'autres combustibles, dans le respect du cycle naturel. C'est sa commodité d'utilisation qui a permis sa large diffusion.

NL Pellets

Het gebruik van pellets, een eco-brandstof uit vernieuwbare bronnen met optimaal thermisch rendement, die makkelijk te verkrijgen, te vervoeren en te bewaren is, zorgt voor een aanzienlijke besparing in vergelijking met andere brandstoffen en respecteert de natuurlijke cyclus. Door hun gebruiksvriendelijkheid zijn pellets inmiddels wijdverspreid.

DE Pellets

Die Verwendung von Pellets, eines ökologischen Brennstoffs aus nachwachsenden Quellen mit optimaler Heizleistung, problemloser Beschaffung und Lagerung, erlaubt nicht nur eine spürbare Ersparnis im Vergleich zu anderen Brennstoffen, sondern auch die Achtung des natürlichen Zyklus. Seine Zweckmäßigkeit hat für seine Verbreitung gesorgt.

ES El pellet

El empleo del pellet, combustible ecológico de fuentes renovables, de óptimo rendimiento térmico, fácil de conseguir y gestionar en cuanto a transporte y almacenaje, ofrece un considerable ahorro en comparación con otras fuentes combustibles, en pleno respeto del ciclo natural. La comodidad de uso que supone ha garantizado una gran aceptación.

CAMINETTI A LEGNA



Caratterizzare un ambiente con la vitalità di un fuoco a legna significa sapersi concedere un grande piacere. Una scelta di buon gusto per indimenticabili momenti.

EN Wood-burning fireplaces

Characterising an environment with the vitality of a wood fire reflects good taste for cherishing pleasant and unforgettable moments.

FR Cheminées à bois

Distinguer une pièce par la vitalité d'un feu de bois, c'est savoir s'offrir un grand plaisir. Un choix de bon goût pour des moments inoubliables.

NL Houthaarden

De vitaliteit van een houtvuur in een ruimte brengen betekent uzelf een groot plezier gunnen. Een goede keus voor onvergetelijke momenten.



DE Kamine für Holzfeuerung

Die Lebendigkeit eines Holzfeuers in einen Raum zu bringen, bedeutet sich ein großes Vergnügen zu gönnen. Eine Entscheidung des guten Geschmacks für unvergessliche Momente.

ES Chimeneas de leña

Caracterizar un espacio con la vitalidad de un fuego de leña significa saberse conceder un gran placer. Una elección de buen gusto para momentos inolvidables.

CAMINETTI A PELLETT



Il calore generato dal fuoco si è reso alla portata di tutti grazie alla praticità d'uso del pellet. Semplicità di impiego, grande funzionalità ed estrema efficienza.

EN Pellet-burning fireplaces

The heat generated from fire is made available to everyone thanks to the practical pellets, which are easy to use, highly functional and extremely efficient.

FR Cheminées à granulés

Grâce à la commodité des granulés, la chaleur générée par le feu est désormais à la portée de tous. Simplicité d'emploi, grande fonctionnalité et efficacité extrême.

NL Pellethaarden

De warmte van het vuur komt binnen ieders bereik dankzij het gebruiksgemak van pellets. Eenvoudig in gebruik, zeer functioneel en buitengewoon efficiënt.



DE Kamine für Pelletfeuerung

Pellets haben sich als sehr praktisch erwiesen und damit die Wärme des Feuers für alle greifbar gemacht. Einfacher Einsatz, große Funktionalität und höchste Effizienz.

ES Chimeneas de pellets

El calor generado por el fuego está hoy al alcance de todos gracias a la comodidad de uso del pellet. Sencillez de uso, gran funcionalidad y extrema eficiencia.

Rivestimenti



Lugano



Sun



Friburgo



Multifuoco[®] System

20°C

- Uniformità di riscaldamento in tutto l'ambiente, dal pavimento al soffitto, senza sprechi.
- Definisci la temperatura di comfort, dove tu sei, Multifuoco[®] la mantiene.
- Percepisci sempre un calore confortevole in tutto il corpo, mai più piedi freddi.
- Uniform heating throughout your living areas, from the floor to the ceiling.
- Set you comfort temperature wherever you are and the Multifuoco[®] system will maintain it.
- Your body will always feel warm and comfortable; no more cold feet.
- Uniformité de chauffage dans toute la pièce du sol au plafond, sans gaspillages.
- Définissez la température de confort où vous vous trouvez, Multifuoco[®] se charge de la maintenir.
- Une chaleur confortable est perçue dans tout le corps. Vous n'aurez plus jamais les pieds froids.

20°C

20°C

- **Gelijkmatige verwarming van de hele ruimte, van de vloer tot het plafond, zonder verspilling.**
- **Definieer de comforttemperatuur waar u bent en Multifuoco® zorgt ervoor.**
- **Altijd een aangename warmte in uw hele lichaam, nooit meer koude voeten.**
- **Gleichmäßige und sparsame Beheizung des gesamten Raums vom Fußboden bis zur Decke.**
- **Stellen Sie Ihre gewünschte Komforttemperatur dort ein, wo sie benötigt wird - Multifuoco® hält sie stabil.**
- **Sie werden immer eine angenehme Wohlfühltemperatur spüren und keine kalten Füße mehr haben.**
- **Uniformidad de calefacción en todo el ambiente, del suelo al techo, sin desperdicios.**
- **Elige tu temperatura de confort donde te encuentres. Multifuoco® la mantiene.**
- **Percibe siempre un calor confortable en todo el cuerpo. Nunca más pies fríos.**



Multifuoco® System

Solo con l'esclusivo Multifuoco® System il calore viene immesso dal basso. Questa caratteristica modalità brevettata consente di mantenere uniforme la temperatura in ambiente, grazie alla generazione di naturali moti convettivi, favoriti dal prelievo dell'aria per il riscaldamento dall'alto. Multifuoco® System evita di stratificare calore in prossimità del soffitto e riscalda anche all'altezza del pavimento (i nostri piedi). Il calore viene distribuito uniformemente in ambiente, ad elevata temperatura e con una bassa velocità in uscita per garantire la massima silenziosità.

FR Seul l'exclusif Multifuoco® System permet l'émission de la chaleur par le bas. Ce mode d'émission breveté permet de garder la température uniforme par génération de mouvements convectifs naturels, favorisés par le prélèvement de l'air de chauffage par le haut. Multifuoco® System évite la stratification de la chaleur près du plafond et chauffe au niveau du sol (pieds). La chaleur est distribuée de façon uniforme, à une température élevée et à faible vitesse en sortie pour un silence assuré.

DE Nur mit dem exklusiven Multifuoco® System streicht die Wärme von unten über den Boden in den Raum. Diese patentierte Betriebsweise ermöglicht es, eine einheitliche Temperatur im Raum herzustellen, die durch natürliche Konvektivbewegungen entsteht, wobei die Luft Beheizung aus dem Bereich über dem angesaugt wird. Multifuoco® verhindert somit die Schichtung der Wärme direkt unter der Decke und heizt auch auf Höhe des Bodens (d.h. die Füße). Die Wärme wird gleichmäßig im Raum verteilt; dies erfolgt mit hoher Auslaß-Temperatur und niedriger Geschwindigkeit, um so maximale Laufruhe zu garantieren.

EN Only with the exclusive Multifuoco® System, heat is introduced into the room from the floor level. This patented characteristic process maintains a unified room temperature, thanks to the natural convection favorites from levy for heating air from above; where air is warmer. The Multifuoco® System prevents heat stratification occurring at ceiling level rendering more heat at floor level compared to conventional stoves. Heat is conveyed uniformly into the room with maximum silence during operation.

NL Alleen met het exclusieve Multifuoco® System wordt de warmte vanaf de vloer over de ruimte verspreid. Met dit gepatenteerde systeem kan de omgevingstemperatuur constant worden gehouden, dankzij de natuurlijke convectiebewegingen waardoor lucht van boven betrekt voor de verwarming. Multifuoco® voorkomt ophoping van warmte in de buurt van het plafond en verwarmt ook op vloerniveau (de hoogte van onze voeten). De warmte wordt gelijkmatig verspreid over de ruimte met een hoge temperatuur en lage snelheid, voor een maximale stille werking.

ES Sólo con el exclusivo Multifuoco® System el calor se introduce en el ambiente desde abajo. Esta característica modalidad patentada permite mantener uniforme la temperatura ambiente gracias a la generación de movimientos convectivos naturales, favorecidos por la toma del aire de calefacción por la parte superior. Multifuoco® System evita estratificar el calor cerca del techo, calentando también a la altura del suelo (pies). El calor se distribuye uniformemente en el ambiente, a alta temperatura y con una baja velocidad de salida, para garantizar el máximo silencio.

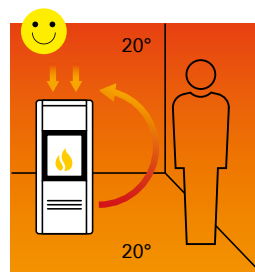

Riscaldamento Multifuoco® System

EN Heating with Multifuoco® System
FR Chauffage Multifuoco® System
NL Multifuoco® System-verwarming
DE Beheizung mit Multifuoco® System
ES Calefacción Multifuoco® System

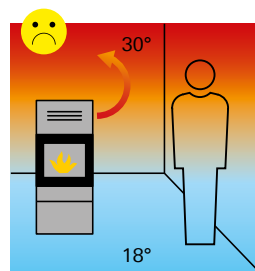

Riscaldamento tradizionale

EN Traditional Heating
FR Chauffage traditionnel
NL Traditionele verwarming
DE Traditionelle Beheizung
ES Calefacción tradicional

Sistema brevettato

- EN** Patented system
- FR** Système breveté
- NL** Gepatenteerd systeem
- DE** Patentiertes System
- ES** Sistema patentado

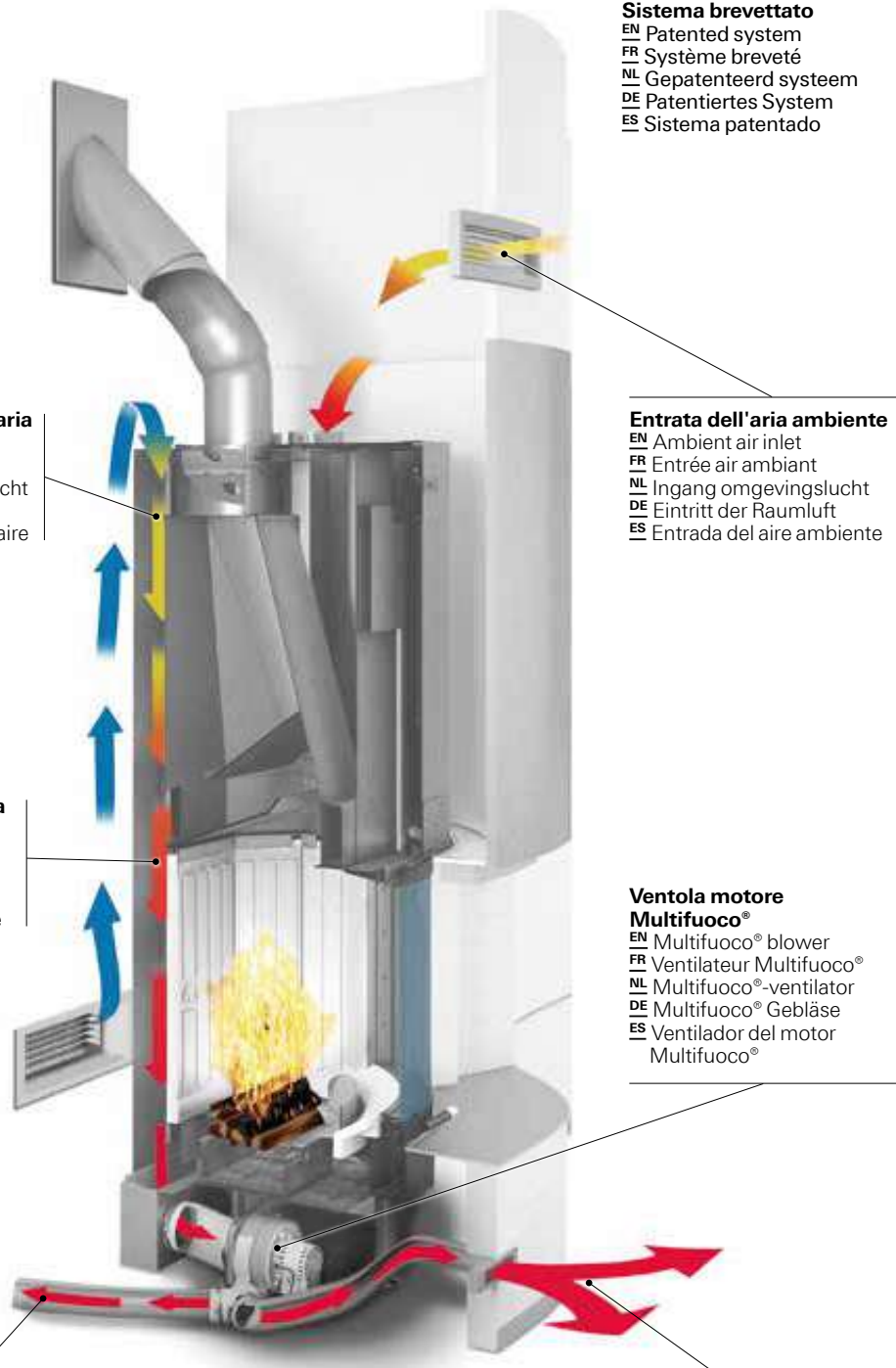

Preriscaldamento aria

- EN** Warm air
- FR** Préchauffage air
- NL** Voorverwarmde lucht
- DE** Vorgewärmte Luft
- ES** Precalementamiento aire

Riscaldamento aria

- EN** Generating hot air
- FR** Chauffage air
- NL** Warme lucht
- DE** Gewärmte Luft
- ES** Calentamiento aire

Entrata dell'aria ambiente

- EN** Ambient air inlet
- FR** Entrée air ambiant
- NL** Ingang omgevingslucht
- DE** Eintritt der Raumluft
- ES** Entrada del aire ambiente

Ventola motore Multifuoco[®]

- EN** Multifuoco[®] blower
- FR** Ventilateur Multifuoco[®]
- NL** Multifuoco[®]-ventilator
- DE** Multifuoco[®] Gebläse
- ES** Ventilador del motor Multifuoco[®]

Uscita aria per canalizzazione

- EN** Ducting outlet
- FR** Sortie air pour canalisation
- NL** Luchtuitgang voor kanalisering
- DE** Luftaustritt zur Kanalisierung
- ES** Salida del aire para la canalización

Uscita aria calda in ambiente

- EN** Hot air vent
- FR** Sortie air chaud dans la pièce
- NL** Uitgang warme lucht in de ruimte
- DE** Austritt der Warmluft in den Raum
- ES** Salida del aire caliente en el ambiente

Canalizzazione con Multifuoco®

Attraverso un semplice sistema di canalizzazione, realizzato con tubi flessibili dal diametro ridotto, è possibile riscaldare anche altri ambienti della casa. La diffusione del calore è ancora più confortevole e uniforme, essendo effettuata da più punti, con bocchette dotate di regolazione di flusso. La facile posa dei condotti di canalizzazione consente di realizzare un sistema di riscaldamento versatile, in locali adiacenti o canalizzabili fino a 16 m. La canalizzazione può essere effettuata orizzontalmente o verticalmente, sia al piano superiore sia a quello inferiore.

EN Ducting with Multifuoco®

Other rooms in the home can benefit from this system which can be simply ducted using small diameter flexible duct pipe. Diffusion of heat is even more notable through multiple flow regulating hot air vents positioned in other rooms. Easy laying of the ducting conduits creates a versatile heating system, in adjacent rooms up to 16 metres. Ducting can be either horizontal or vertical runs and the system will perform on either upper or lower floors.



FR Canalisation avec Multifuoco®

A travers un simple système de canalisation, réalisé avec des conduits flexibles de faible diamètre, il est possible de chauffer d'autres pièces de la maison. La diffusion de la chaleur, à travers des bouches de diffusion pourvues d'un réglage de flux, est encore plus confortable et uniforme. La pose aisée des conduits de canalisation permet de réaliser un système de chauffage polyvalent, dans les pièces voisines ou canalissables jusqu'à 16 m. La canalisation peut être horizontale ou verticale, tant à l'étage supérieur qu'inférieur.

NL Kanalisering met Multifuoco®

Door middel van een eenvoudig kanalisatiesysteem, uitgevoerd met flexibele leidingen met een kleine diameter, kunnen ook andere kamers in de woning worden verwarmd. De verspreiding van de warmte is nog comfortabeler en gelijkmatiger doordat zij plaatsvindt vanaf meerdere punten, met openingen die voorzien zijn van luchtstromeregeling. Dankzij de eenvoudige plaatsing van de kanalisatie-leidingen kan een veelzijdig verwarmingssysteem worden gerealiseerd in naastliggende ruimtes tot 16 m. De kanalisering kan horizontaal of verticaal worden uitgevoerd, zowel op de boven- of als onderverdieping.

DE Kanalisierung mit Multifuoco®

Über ein einfaches Kanalsystem aus flexiblen Rohrleitungen mit reduziertem Durchmesser ist es möglich, auch andere Räume zu beheizen. Die Verteilung der Wärme erfolgt noch komfortabler und gleichmäßiger, da sie an mehreren Stellen über Öffnungen mit Luftstromregelung austritt. Die problemlose Verlegung der Rohrleitungen erlaubt die Realisierung eines vielseitigen Heizsystems in angrenzende Räume oder mit Kanalisierungen bis 16 m Länge. Das Kanalsystem kann horizontal bzw. vertikal sowohl in die darüber als auch in die darunter liegende Etage verlegt werden.

ES Canalización con Multifuoco®

A través de un simple sistema de canalización, realizado con tubos flexibles de diámetro reducido, es posible calentar también otros ambientes de la casa. La difusión del calor es aún más confortable y uniforme, ya que se efectúa por varios puntos, con bocas dotadas de regulación de flujo. La fácil colocación de los conductos de canalización permite realizar un sistema de calefacción versátil, en ambientes adyacentes o canalizables hasta 16 m. La canalización puede realizarse horizontal o verticalmente, ya sea sobre el piso superior o el inferior.



Flexible Ducts Ø 75 mm



Rivestimenti



City



Kensington



Capital



Caratteristiche

MULTIFUOCO® SYSTEM



Sistema di ventilazione brevettato che garantisce una temperatura uniforme in ambiente, dal pavimento al soffitto, senza sprechi. Canalizzabile in altri ambienti.

EN Multifuoco® System

Patented ventilation system that guarantees uniform temperatures within the room, from the floor to the ceiling, without wastages. Ductable to other rooms.

FR Multifuoco® System

Système de ventilation breveté qui garantit une température uniforme dans la pièce, du sol au plafond, sans gaspillage. Possibilité de canaliser la chaleur vers d'autres pièces.

NL Multifuoco® System

Het gepatenteerde ventilatiesysteem garandeert een gelijkmatige temperatuur in de kamer, van de vloer tot aan het plafond, zonder verspilling. Kanaliseerbaar in andere ruimtes.

DE Multifuoco® System

Das exklusive patentierte Lüftungssystem sorgt für eine gleichmäßige Temperatur im Raum, vom Fußboden bis zur Decke, ohne Verschwendung. Über Kanäle können auch andere Räume mitgeheizt werden.

ES Multifuoco® System

Sistema de ventilación patentado que garantiza una temperatura uniforme en el ambiente, del suelo al techo, sin derroches. Canalizable a otros ambientes.



MULTIFUOCO® SYSTEM PLUS



Nei focolari a legna è possibile installare la versione System Plus. Sistema di ventilazione Multifuoco® con controllo totalmente elettronico della ventola.

EN Multifuoco® System Plus

The System Plus version of the exclusive Multifuoco® ventilation system can be installed on wood-burning fireboxes with fully automatic control of the fan.

FR Multifuoco® System Plus

Pour les foyers à bois, il est possible de choisir d'installer la version System Plus du système exclusif de ventilation Multifuoco® ce qui permet un contrôle entièrement électronique du ventilateur.

NL Multifuoco® System Plus

In de vuurhaarden op hout kan de System Plus-uitvoering geïnstalleerd worden. Ventilatiesysteem Multifuoco® met geheel elektronische besturing van de ventilator.

DE Multifuoco® System Plus

Bei Holz-Feuerräumen kann auch die Version System Plus des exklusiven Lüftungssystems Multifuoco installiert werden, mit dem das Gebläse komplett elektronisch gesteuert werden kann.

ES Multifuoco® System Plus

Para los hogares de leña se puede elegir la versión System Plus con su exclusivo sistema de ventilación Multifuoco® lo que permite tener un control totalmente electrónico del ventilador.



DUAL POWER



Due motori indipendenti garantiscono un flusso di aria calda nei diversi locali. La portata dei motori è modulata separatamente. Disponibile per i focolari a pellet.

EN Dual Power

Two independent motors ensure a flow of hot air to the various rooms. The capacity of the motors is modulated separately. Available for pellet-burning fireboxes.

FR Dual Power

Deux moteurs indépendants assurent la distribution de l'air chaud dans les différentes pièces. La portée des moteurs est modulée séparément. Fonction disponible sur les foyers à granulés.

NL Dual Power

Twee onafhankelijke motoren garanderen een warme luchtstroom in de verschillende ruimtes. De capaciteit van de motoren wordt apart gemoduleerd. Verkrijgbaar voor vuurhaarden op pellets.

DE Dual Power

Zwei unabhängige Gebläsemotoren garantieren den Warmluftstrom in die verschiedenen Räume. Die Förderleistung der Gebläsemotoren wird getrennt moduliert. Erhältlich für Pellet-Feuerräume.

ES Dual Power

Dos motores independientes garantizan un flujo de aire caliente en los distintos ambientes. La capacidad de los motores se modula separadamente. Disponible para los hogares de pellets.



MULTICOMFORT



Nei focolari a pellet, con Multicomfort, la temperatura viene rilevata dalla sonda ambiente del telecomando. Gli inserti IP-MP possono collegarsi ad un termostato esterno.

EN Multicomfort

For pellet-burning, with Multicomfort, the temp. is measured by the ambient probe on the remote control. For IP-MP inserts, it's possible to connect to an external thermostat.

FR Multicomfort

Dans les foyers à granulés, avec la fonction Multicomfort, la température est détectée par la sonde ambiante présente dans la télécommande. Les inserts IP-MP permettent la connexion à un thermostat extérieur.

NL Multicomfort

In de vuurhaarden op pellets wordt met de Multicomfort-functie de temperatuur gedetecteerd door de omgevingssensor in de afstandsbediening. De IP-MP-inzetstukken kunnen worden aangesloten op een externe thermostaat.

DE Multicomfort

Bei Pellet-Feuerräumen wird mit der Multicomfort-Funktion die Temperatur durch den Fühler in der Fernbedienung gemessen. Bei den Einsätzen der Baureihe IP-MP kann ein Außenthermostat angeschlossen werden.

ES Multicomfort

En los hogares de pellets, con la función Multicomfort, la temperatura se detecta mediante la sonda ambiente presente en el mando a distancia. Para los hogares IP-MP, es posible conectarse a un termostato externo.



APP



Con un modulo optional, è possibile gestire le funzioni del caminetto a pellet anche quando si è fuori casa mediante l'App My Piazzetta.

EN App

Thanks to an ancillary unit installable as an optional feature, it is possible to switch the pellet-burning fireplace on/off and manage its functions even away from home with My Piazzetta app.

FR App

Grâce à un module accessoire pouvant être installé en option, il est possible d'allumer, d'éteindre et de gérer les fonctions de la cheminée à granulés à distance de l'application My Piazzetta.

NL App

Met een optionele module kunnen de functies van de pellethaard ook bestuurd worden als u niet thuis bent via de My Piazzetta-app.

DE Sms - App

Dank eines optional installierbaren Moduls können Sie den Kamin mit die App My Piazzetta auch dann ein-/ausschalten und seine Funktionen steuern, wenn Sie außer Haus sind.

ES Sms - App

Gracias a un módulo adicional que puede instalarse como elemento opcional, es posible encender, apagar y gestionar las funciones de la chimenea aun estando fuera de casa mediante la App My Piazzetta.



EASY TO CLEAN



Un cassetto di raccolta della cenere, in acciaio verniciato comodamente estraibile, rende particolarmente agili e pratiche le operazioni di pulizia.

EN Easy to clean

A high-thickness, spacious ash tray made of painted steel, easy to remove and to empty, makes cleaning operations very quick and easy.

FR Facilité de nettoyage

Grâce au grand tiroir à cendres en acier peint de forte épaisseur, coulissant et simple à vider, les opérations de nettoyage sont particulièrement faciles et pratiques.

NL Makkelijk te reinigen

Een makkelijk uittrekbare aslade van gelakt staal maakt het reinigen bijzonder snel en praktisch.

DE Einfach zu reinigen

Ein Aschekasten mit großem Fassungsvermögen aus lackiertem Stahl mit hoher Wandstärke, ausziehbar und leicht zu entleeren, macht das Reinigen besonders bequem und einfach.

ES Limpieza fácil

Un espacioso cajón de cenizas de acero pintado de alto espesor, fácil de extraer y de vaciar, agiliza al máximo las operaciones de limpieza.



Caratteristiche

STEEL STRUCTURE



La solidità di costruzione dei caminetti Piazzetta garantisce che mantengano le loro caratteristiche nel tempo, grazie ad un'accurata progettazione e alla qualità dell'acciaio di forte spessore.

EN Steel structure

The sturdy structure of Piazzetta fireplaces ensures that they retain their characteristics over time, thanks to attentive design and the premium-quality, high-thickness steel.

FR Structure en acier

La solidité de fabrication des cheminées Piazzetta garantit la préservation de leurs caractéristiques dans le temps, grâce à une conception soignée et à la qualité de l'acier de forte épaisseur.

NL Stalen constructie

De solide constructie van de Piazzetta-haarden garandeert een lange levensduur, dankzij een nauwkeurig ontwerp en de kwaliteit van het gebruikte staal.

DE Stahlkonstruktion

Die solide Konstruktion der Piazzetta Kamine sorgt dafür, dass sie ihre Eigenschaften dauerhaft beibehalten. Sie sind sorgfältig konstruiert und aus hochwertigem Stahl mit hoher Wandstärke gefertigt.

ES Estructura de acero

La solidez de construcción de las chimeneas Piazzetta garantiza el mantenimiento de sus características a lo largo del tiempo, gracias a un atento diseño y la calidad del acero de alto espesor.



GOOD HEAT OUTPUT



La qualità di distribuzione del calore in ambiente garantisce il massimo comfort e regolando il livello di calore si ottiene miglior beneficio ed efficienza del fuoco a legna e a pellet.

EN Good Heat Output

The quality of the heat distribution throughout the room ensures maximum comfort, while the heat level adjustment allows for taking full advantage of the wood and pellet fire's efficiency.

FR Bonne puissance calorifique

La qualité de répartition de la chaleur dans la pièce garantit un confort maximal et la régulation du niveau de chaleur permet de tirer le meilleur bénéfice possible du feu de bois et des granulés.

NL Goede warmte-uitvoer

De kwaliteit van de warmteverspreiding in de ruimte garandeert een maximaal comfort. Door het warmteniveau te regelen profiteert u maximaal van de efficiëntie van het hout- of pelletvuur.

DE Gute Wärmeabgabe

Die gute Wärmeverteilung im Raum sorgt für höchsten Komfort. Durch die Regelung der Wärmeabgabe können Nutzen und Effizienz der Holz- bzw. Pelletfeuerung optimiert werden.

ES Buena salida de calor

La calidad de distribución del calor en el ambiente garantiza el máximo confort, mientras que la regulación del nivel de calor permite obtener los más altos valores de utilidad y eficiencia del fuego de leña y pellets.



EXTERNAL AIR KIT



I focolari a legna e a pellet possono essere dotati di un kit per prelevare l'aria comburente dall'esterno, senza sottrarre aria ed ossigeno dall'ambiente. Soluzione efficace in qualsiasi tipo di abitazione.

EN External Air Kit

The wood-burning and pellet-burning fireboxes can be fitted with a kit for drawing primary combustion air from the outside, so as to avoid using up the air and oxygen inside the room. An effective solution for any type of home.

FR Kit air extérieur

Les foyers à bois et à granulés peuvent être équipés d'un kit pour prélever l'air comburant à l'extérieur, évitant de puiser l'air et l'oxygène dans la pièce. Une solution efficace pour n'importe quel type d'habitation.

NL Externe luchtkit

De vuurhaarden op hout en op pellets kunnen worden uitgerust met een kit om verbrandingslucht van buiten te betrekken, zodat er geen lucht en zuurstof aan de kamer wordt onttrokken.

DE Außenluft-Bausatz

Die Holz- und Pellet-Feuerräume können mit einem Bausatz ausgerüstet werden, der die Verbrennungsluft von außen zuführt, damit dem Wohnraum kein Sauerstoff entzogen wird: eine optimale Lösung für jede Wohnung.

ES Kit de aire exterior

Los hogares de leña y pellets pueden dotarse de un kit para tomar el aire de combustión del exterior, sin robar aire y oxígeno al ambiente. Solución eficaz en cualquier tipo de vivienda.



HERMETIC FIREBOX



I modelli con focolare ermetico possono prelevare l'aria comburente dall'esterno, non consumano l'ossigeno dell'ambiente d'installazione. Sono adatti per case passive, ma anche tradizionali.

EN Hermetic Firebox

Hermetic models can withdraw the combustion air from the outside, thus not utilizing oxygen within the room where the unit is installed. Suitable for both energy efficient and traditional homes.

FR Foyer Étanche

Les modèles à foyer étanche peuvent capter l'air de combustion de l'extérieur, ils ne consomment pas l'oxygène de l'environnement d'installation. Adaptés aux maisons passives, mais aussi traditionnelles.

NL Hermetische haarden

Hermetische modellen kunnen de lucht voor verbranding onttrekken van buitenaf, zo wordt er geen zuurstof onttrokken uit de ruimte daar waar het toestel is geïnstalleerd. Geschikt voor zowel energiezuinige als traditionele woningen.

DE RLU Brennkammer

Modelle mit RLU Brennkammer können die Verbrennungsluft von außen aufnehmen und verbrauchen somit nicht den Sauerstoff des Installationsraum. Geeignet für Passiv, aber auch für traditionelle Häuser.

ES Hogar Hermético

Los modelos con hogar hermético pueden tomar el aire comburente desde el externo, no consuman el oxígeno del ambiente de instalación. Son adecuados para casas pasivas, y también tradicionales.



PELLET LEVEL SENSOR



Dotati di numerose funzioni per una facile gestione, i focolari a pellet, grazie ad un sensore nel serbatoio, sono in grado di inviare sul telecomando un avviso quando è necessaria una ricarica.

EN Pellet level sensor

Equipped with several functions to facilitate their management, the pellet-burning fireboxes - thanks to a sensor fitted in the tank - are able to send an alert message to the remote control when they need to be reloaded.

FR Capteur de niveau des granulés

Dotés de nombreuses fonctions pour faciliter la gestion, les foyers à granulés, grâce à un capteur présent dans le réservoir, peuvent envoyer une notification sur la télécommande quand il faut remettre des granulés.

NL Pelletniveau sensor

De vuurhaarden op pellets kunnen dankzij een sensor in de pellereservoir een signaal naar de afstandsbediening sturen dat er pellets moeten worden bijgevuld.

DE Pellet-Füllstandsensor

Die Pellet-Feuerräume sind mit zahlreichen Funktionen für einfache Bedienung ausgerüstet. Über einen Sensor im Behälter sind sie in der Lage, an die Fernbedienung eine Warnung zu senden, wenn nachgefüllt werden muss.

ES Sensor de nivel del pellet

Los hogares de pellets, provistos de numerosas funciones que facilitan la gestión, cuentan con un sensor en el depósito que les permite avisar al mando a distancia si requieren una recarga.



MULTIFUNCTION REMOTE CONTROL



Con un pratico telecomando, che rileva anche la temperatura ambiente, è possibile gestire tutte le funzioni del focolare a pellet, anche attraverso una programmazione.

EN Multifunction Remote Control

A practical remote control, which also measures the ambient temperature, allows for managing all the functions by setting the operating modes of the pellet-burning firebox, also through programming.

FR Télécommande multifonctions

Avec une télécommande très pratique, qui détecte également la température ambiante, il est possible de gérer toutes les fonctions en paramétrant les modalités d'utiliser du foyer à granulés, même par programmation.

NL Multifunctionele afstandsbediening

Met de praktische afstandsbediening die tevens de omgevingstemperatuur aangeeft, kunnen alle functies van de vuurhaard op pellets geregeld worden, ook door middel van programmering.

DE Multifunktionale Fernbedienung

Über eine praktische Fernbedienung, die auch die Raumtemperatur misst, können sämtliche Funktionen gesteuert werden. Dazu können die Betriebsarten des Pellet-Feuerraums eingestellt bzw. programmiert werden.

ES Mando a distancia multifunción

Un práctico mando a distancia, que además detecta la temperatura ambiente, permite administrar todas las funciones, configurando las modalidades de uso del hogar de pellets, gracias también a la programación.



Rivestimenti





Gallery



Salisburgo



Cruise

MC BL



FOCOLARI COMPATTI CON ANTA BASCULANTE

Perfetta sintesi di tecnologia all'avanguardia e pulizia estetica. La serie di Focolari Compatti MC a legna, offre innumerevoli soluzioni d'installazione in poco spazio. Nuove forme moderne e vetro serigrafato incorniciano il fuoco e lo rendono il protagonista della casa.

FR Monoblocs compacts avec porte basculante
Synthèse parfaite de technologie et de sobriété esthétique, la série des monoblocs compacts MC offre d'innombrables solutions d'installation dans les espaces réduits. Les nouvelles formes modernes et la vitre sérigraphiée encadrent le feu et font de lui un acteur à part entière de la maison.

DE Kompakte heizeinsätze mit tür
Die perfekte Synthese von Technologie und sauberen Linien. Die kompakten Heizeinsätze der Baureihe MC für Holzfeuerung lassen zahlreiche Installationslösungen auf geringem Raum zu. Neue, moderne Formen und Glas mit Siebdruck rahmen das Feuer ein, das somit zum Mittelpunkt des Hauses wird.

EN Compact fireboxes with tilting door
A perfect blend of cutting-edge technology and sober aesthetics. The wood-burning MC Compact Firebox range offers countless installation solutions in limited spaces. New modern profiles and screen-printed glass enclose the fire, making it the distinctive feature of the home.

NL Compacte vuurhaarden met kanteldeur
De perfecte synthese van geavanceerde technologie en esthetiek. De serie Compacte monoblokken MC op hout biedt ontelbare installatie-oplossingen voor kleine ruimtes. Nieuwe moderne vormen en gezeefdrukt glas omlijsten het vuur en maken dit tot het hart van het huis. Omkeerbare deur met verzonken handgreep

ES Monobloques compactos con puerta basculante
Perfecta síntesis de tecnología de vanguardia y prolijidad estética. La serie de Monobloques Compactos MC de leña ofrece innumerables soluciones de instalación para espacios pequeños. Las formas modernas y el vidrio serigrafiado enmarcan el fuego y lo hacen protagonista del hogar.



MC 80/64 BL



Energy class		A
Type		MC 65/60
Room heating capacity	m ³	185 - 315
Nominal heat output	kW	11,0
Thermal efficiency	%	80,0
Nominal consumption	kg/h	3,1
Flue outlet	Ø	18
Weight	kg	175
Dimensions	cm	82,5x47x76,5

MAIN FEATURES



GENERAL CHARACTERISTICS

OPTIONAL

- Adjustable feet
- Vacuum

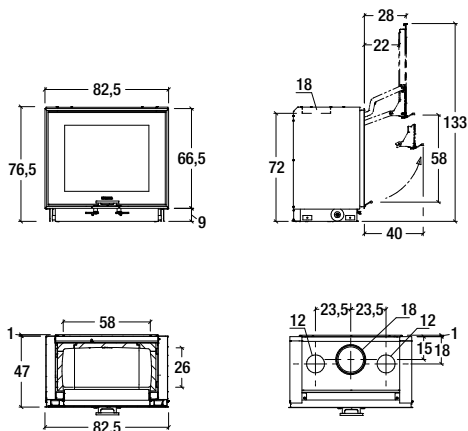

Model: MC 80/64 BL

Rivestimenti disponibili - Available surrounds P.98

MC 85/55 BL



Energy class		A
Type		MC 70/51
Room heating capacity	m ³	185 - 315
Nominal heat output	kW	11,0
Thermal efficiency	%	79,0
Nominal consumption	kg/h	2,9
Flue outlet	Ø	18
Weight	kg	160
Dimensions	cm	87,5x47,3x67,5

MAIN FEATURES



GENERAL CHARACTERISTICS

OPTIONAL

- Adjustable feet
- Vacuum

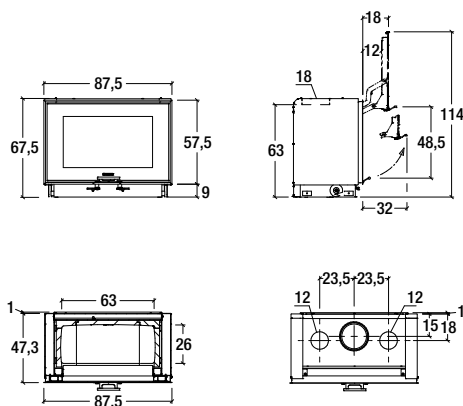

Model: MC 85/55 BL

Rivestimenti disponibili - Available surrounds P.98

MC 105/48 BL



Energy class		A
Type		MC 90/44
Room heating capacity	m ³	205 - 350
Nominal heat output	kW	12,2
Thermal efficiency	%	79,3
Nominal consumption	kg/h	3,2
Flue outlet	Ø	20
Weight	kg	180
Dimensions	cm	107,5x47,3x60,5

MAIN FEATURES



GENERAL CHARACTERISTICS

OPTIONAL

- Adjustable feet
- Vacuum

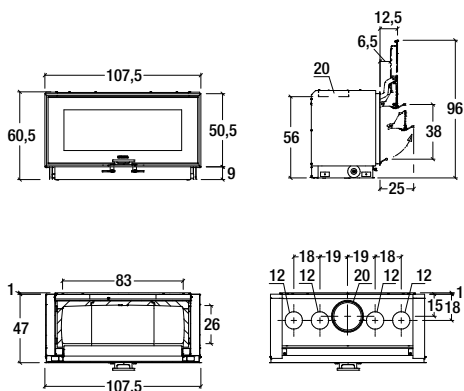

Model: MC 105/48 BL

Rivestimenti disponibili - Available surrounds P.98

PIAZZETTA

MC 133/52 BL



Energy class		A
Type		MC 120/48
Room heating capacity	m ³	235 - 405
Nominal heat output	kW	14,1
Thermal efficiency	%	78,9
Nominal consumption	kg/h	3,8
Flue outlet	Ø	20
Weight	kg	230
Dimensions	cm	135,5x47,3x64,5

MAIN FEATURES



GENERAL CHARACTERISTICS

OPTIONAL

- Adjustable feet
- Vacuum

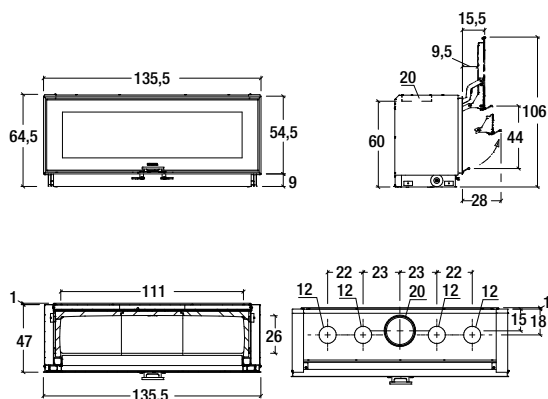

Model: MC 133/52 BL

Rivestimenti disponibili - Available surrounds P.98



MC SL



FOCOLARI COMPATTI CON ANTA SALISCENDI

I Focolari Compatti MC SL a legna, fondono pulizia estetica e praticità d'utilizzo grazie alla pratica e funzionale apertura a saliscendi che scorre a scomparsa verso l'alto. L'ampio vetro serigrafato consente di godere di una piacevole visione della fiamma. L'estrema linearità costruttiva offre innumerevoli soluzioni d'installazione.

FR Monoblocs compacts avec porte à ouverture verticale

Les monoblocs compacts MC SL associent sobriété esthétique et commodité d'utilisation grâce à leur porte très pratique à ouverture verticale qui disparaît en coulissant vers le haut. La grande vitre sérigraphiée assure une agréable vision de la flamme. L'extrême linéarité de construction offre d'innombrables solutions d'installation.

DE Kompakte heizeinsätze mit öffnung durch hebe- und senksystem

Die kompakten Heizeinsätze MC SL für Holzfeuerung vereinen saubere Linien und Benutzerfreundlichkeit mit dem praktischen und funktionalen Hebe- und Senksystem zum Öffnen der Tür. Die große Scheibe mit Siebdruck bietet eine angenehme Sicht auf die Flamme. Die strikte Linearität dieses Produkts lässt zahlreiche Installationslösungen zu.

EN Compact fireboxes with lifting door

The wood-burning MC SL Compact Fireboxes blend sober aesthetics and ease of use thanks to the practical and functional lifting system that slides upwards and is concealed when open. The broad screen-printed glass ensures a pleasant view of the flame. Their extremely linear forms guarantee countless installation options.

NL Compacte vuurhaarden met verticale schuifdeur

In de Compacte monoblokken MC SL op hout smelten esthetiek en gebruiksgemak samen dankzij de praktische en functionele verticale schuifdeur. Het royale gezeefdrukte glas zorgt voor een aangenaam zicht op de vlammen. De lineaire constructie biedt ontelbare installatie-oplossingen.

ES Monobloques compactos con puerta corredera vertical

Los Monobloques Compactos MC SL de leña unen la prolijidad estética a la comodidad de uso gracias a la práctica y funcional apertura por desplazamiento vertical escamoteable. El amplio vidrio serigrafado permite disfrutar de una agradable vista de la llama. La extrema linealidad constructiva ofrece innumerables soluciones de instalación.



MC 65/60 SL



Energy class		A
Type		MC 65/60
Room heating capacity	m ³	185 - 315
Nominal heat output	kW	11,0
Thermal efficiency	%	80,0
Nominal consumption	kg/h	3,1
Flue outlet	Ø	18
Weight	kg	202
Dimensions	cm	73x51x136

MAIN FEATURES



GENERAL CHARACTERISTICS

OPTIONAL

- Adjustable feet
- Vacuum

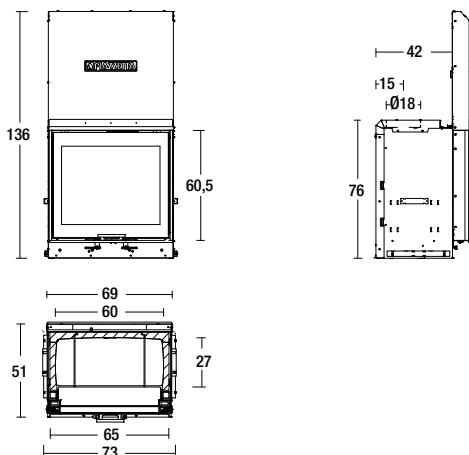

Model: MC 65/60 SL

Rivestimenti disponibili - Available surrounds P.98

MC 70/51 SL



Energy class		A
Type		MC 70/51
Room heating capacity	m ³	185 - 315
Nominal heat output	kW	11,0
Thermal efficiency	%	79,0
Nominal consumption	kg/h	2,9
Flue outlet	Ø	18
Weight	kg	195
Dimensions	cm	78x51x118

MAIN FEATURES



GENERAL CHARACTERISTICS

OPTIONAL

- Adjustable feet
- Vacuum

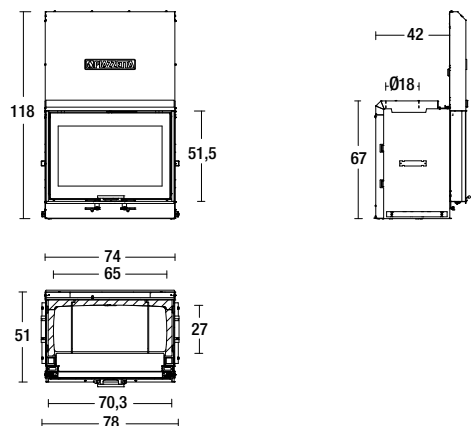

Model: MC 70/51 SL

Rivestimenti disponibili - Available surrounds P.98

MC 90/44 SL



Energy class		A
Type		MC 90/44
Room heating capacity	m ³	205 - 350
Nominal heat output	kW	12,2
Thermal efficiency	%	79,3
Nominal consumption	kg/h	3,2
Flue outlet	Ø	20
Weight	kg	160
Dimensions	cm	98x51x104

MAIN FEATURES



GENERAL CHARACTERISTICS

OPTIONAL

- Adjustable feet
- Vacuum

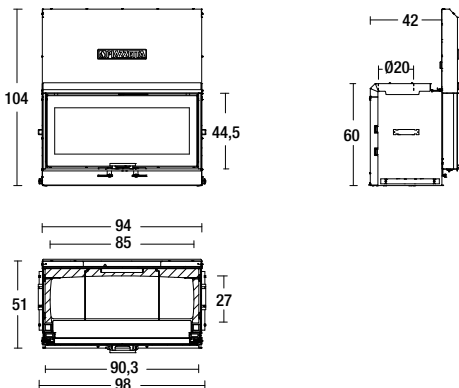

Model: MC 90/44 SL

Rivestimenti disponibili - Available surrounds P.98

PIAZZETTA

MC 120/48 SL



Energy class		A
Type		MC 120/48
Room heating capacity	m ³	235 - 405
Nominal heat output	kW	14,1
Thermal efficiency	%	78,9
Nominal consumption	kg/h	3,8
Flue outlet	Ø	20
Weight	kg	280
Dimensions	cm	126x51x112

MAIN FEATURES



GENERAL CHARACTERISTICS

OPTIONAL

- Adjustable feet
- Vacuum

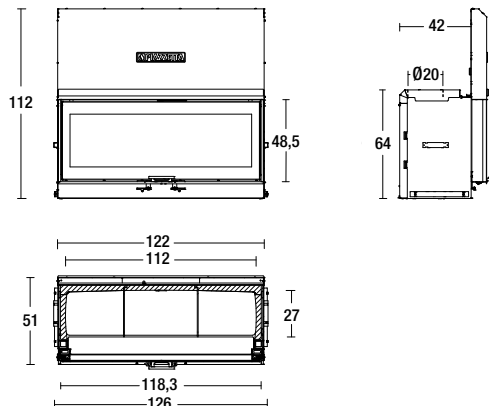

Model: MC 120/48 SL

Rivestimenti disponibili - Available surrounds P.98



FOCOLARI COMPATTI

La serie Focolari Compatti MC a legna offre innumerevoli soluzioni di installazione grazie all'estrema linearità costruttiva. Nuove forme moderne e vetro serigrafato incorniciano il fuoco e lo rendono il protagonista della casa. Ampio piano fuoco e doppio sistema di aria terziaria preriscaldata che ottimizza la combustione e i rendimenti. Porta reversibile con maniglia a scomparsa.

FR Monoblocs compacts

La série de monoblocs compacts MC offre une foule de solutions d'installation grâce à son extrême linéarité de construction. Les nouvelles formes modernes et la vitre sérigraphiée encadrent le feu et font de lui la star de la maison. Large sole foyère et double système d'air tertiaire préchauffé optimisant la combustion et les rendements. Porte réversible avec poignée escamotable.

DE Kompakte heizeinsätze

Die kompakten Heizeinsätze der Baureihe MC für Holzfeuerung lassen dank strikter Linearität zahlreiche Installationslösungen zu. Moderne Formen und Glas mit Siebdruck umrahmen das Feuer und machen es zum Mittelpunkt des Hauses. Großer Feuerstisch und doppeltes System für vorgewärmte Tertiärluft zur Verbrennungs- und Leistungsoptimierung. Umkehrbare Tür mit versenkbarem Griff.

EN Compact fireboxes

The wood-burning MC Compact Firebox range offers countless installation options thanks to extremely linear profiles. New modern forms and screen-printed glass enclose the fire, making it the distinctive feature of the home. Broad hearth and dual system for pre-heated tertiary air that optimises combustion and performances. Reversible door with recessed handle.

NL Compacte vuurhaarden

De serie Compacte monoblokken MC op hout biedt ontelbare installatie-oplossingen dankzij hun lineaire constructie. Nieuwe moderne vormen en gezeefdrukt glas omlijsten het vuur en maken dit tot het hart van het huis. Een brede haard en dubbel systeem voor voorverwarmde tertiaire lucht dat de verbranding en het rendement optimaliseert.

ES Monobloques compactos

La serie Monobloques Compactos MC de leña ofrece numerosas opciones de instalación gracias a la extrema linealidad constructiva. Las formas modernas y el vidrio serigrafiado enmarcan el fuego y lo hacen protagonista del hogar. Amplio plano de fuego y doble sistema de aire terciario precalentado que optimiza la combustión y el rendimiento. Puerta reversible con tirador abatible.





Versione con mantello cappa optional / With hood cover optional

Energy class		A+
Type		MC 65/60-01
Room heating capacity	m ³	185 - 315
Nominal heat output	kW	10,0
Thermal efficiency	%	87,0
Nominal consumption	kg/h	2,8
Flue outlet	Ø	18
Weight	kg	225
Dimensions	cm	73,5x47,2x175,3

MAIN FEATURES



GENERAL CHARACTERISTICS

- Steel firebox

OPTIONAL

- Hood cover
- Adjustable feet
- Vacuum

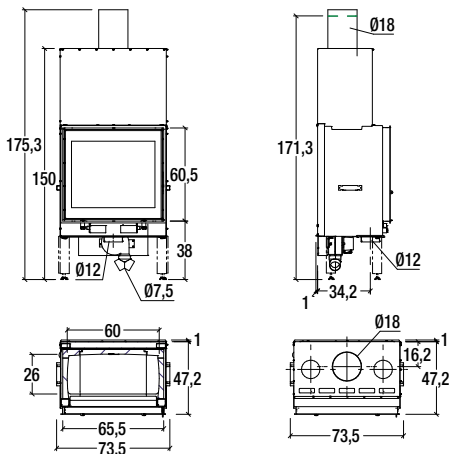

Model: MC 65/60 PLUS

Con mantello cappa / With hood cover

Rivestimenti disponibili - Available surrounds P.98



Energy class		A
Type		MC 65/60
Room heating capacity	m ³	185 - 315
Nominal heat output	kW	11,0
Thermal efficiency	%	80,0
Nominal consumption	kg/h	3,1
Flue outlet	Ø	18
Weight	kg	155
Dimensions	cm	73,5x48x76

MAIN FEATURES



GENERAL CHARACTERISTICS

OPTIONAL

- Adjustable feet
- Vacuum

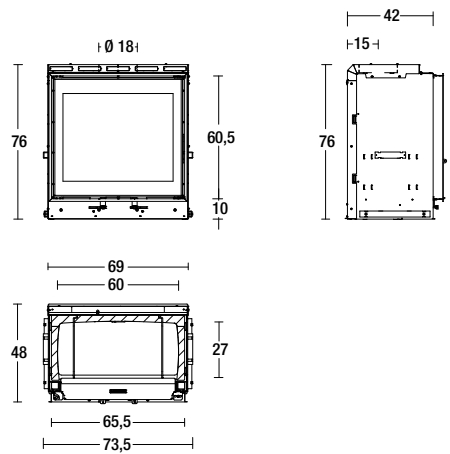

Model: MC 65/60

Rivestimenti disponibili - Available surrounds P.98

MC 70/51



Energy class		A
Type		MC 70/51
Room heating capacity	m ³	185 - 315
Nominal heat output	kW	11,0
Thermal efficiency	%	79,0
Nominal consumption	kg/h	2,9
Flue outlet	Ø	18
Weight	kg	140
Dimensions	cm	78,5x48x67

MAIN FEATURES



GENERAL CHARACTERISTICS

OPTIONAL

- Adjustable feet
- Vacuum

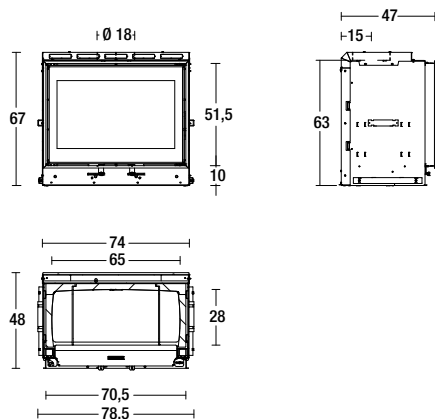

Model: MC 70/51

Rivestimenti disponibili - Available surrounds P.98

PIAZZETTA

MC 90/44



Energy class		A
Type		MC 90/44
Room heating capacity	m ³	205 - 350
Nominal heat output	kW	12,2
Thermal efficiency	%	79,3
Nominal consumption	kg/h	3,2
Flue outlet	Ø	20
Weight	kg	160
Dimensions	cm	98,5x48x60

MAIN FEATURES



GENERAL CHARACTERISTICS

OPTIONAL

- Adjustable feet
- Vacuum

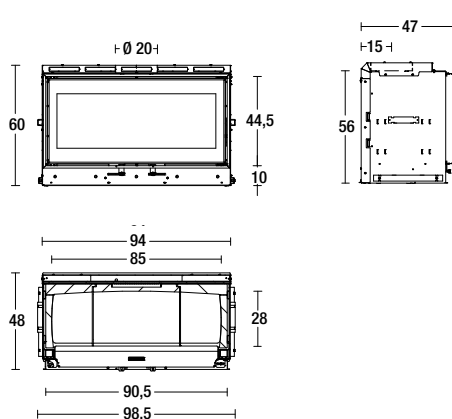

Model: MC 90/44

Rivestimenti disponibili - Available surrounds P.98



Energy class		A
Type		MC 120/48
Room heating capacity	m ³	235 - 405
Nominal heat output	kW	14,1
Thermal efficiency	%	78,9
Nominal consumption	kg/h	3,8
Flue outlet	Ø	20
Weight	kg	200
Dimensions	cm	126x48x64

MAIN FEATURES



GENERAL CHARACTERISTICS

OPTIONAL

- Adjustable feet
- Vacuum

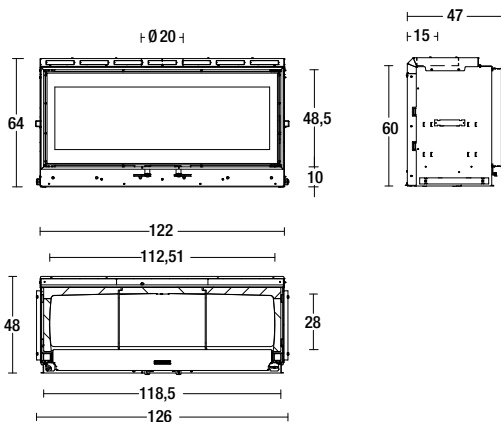

Model: MC 120/48

Rivestimenti disponibili - Available surrounds P.98

MONOBLOCCHI ESTETICI AD ALTA EFFICIENZA

Nuova gamma di Monoblocchi di Design. Anta minimalista con profili di spessore ridotto. Nuovo sistema di saliscendi con innovativo e calibrato movimento. Focolare interamente rivestito in Aluker, registro fumi integrato. Scambiatore superiore compatto e di facile installazione. Conforme a Ecodesign 2022.

FR Monoblocs esthétiques a haut rendement
Nouvelle gamme de Monoblocs Design. Porte minimaliste avec profils d'épaisseur réduite. Nouveau système coulissant avec mouvement innovant et calibré. Foyer entièrement recouvert d'Aluker, registre des fumées intégré. Échangeur supérieur de faible l'installation. Conforme à l'Ecodesign 2022.

DE Ästhetische heizeinsätze mit hochleistung
Neue Reihe von Design- Heizeinsätzen. Minimalistische Türe mit reduzierten Profilen. Neues Hochschiebesystem der Türe mit innovativer und kalibrierter Bewegung. Heizeinsatz komplett mit Aluker verkleidet, integrierte Drosselklappe. Kompakter oberer Wärmetauscher zur Vereinfachung der Installation. In Übereinstimmung mit Ecodesign 2022.

EN Aesthetic type fireboxes high efficiency
A new range of wood-burning fireboxes with a flair for design. A door with clean lines and thin profiles. New innovative and precision rise and fall door. Fire chamber completely dressed in Aluker, an integrated smoke register. A compact heat exchanger, for easy installation. Conforms to Ecodesign 2022.

NL Esthetische monoblokken met hoog rendement
Nieuw assortiment Design Monoblocks. Minimalistische deur met profielen met gereduceerde dikte. Nieuw schuifstelsysteem met innovatieve en gekalibreerde beweging. Haard volledig bedekt met Aluker, geïntegreerd rookregister. Compacte warmtewisselaar boven voor eenvoudige installatie. In overeenstemming met Ecodesign 2022.

ES Monobloques estéticos de alta eficiencia
Nueva gama de Monobloques de Design. Puerta minimalista con perfiles de espesor reducido. Nuevo sistema de apertura a desplazamiento vertical con movimiento innovador y calibrado. Hogar completamente revestido en Aluker, registro humos integrado. Intercambiador superior compacto para una fácil instalación. Conforme con Ecodesign 2022.





Energy class		A+
Type		ME70-01
Room heating capacity	m ³	245 - 415
Nominal heat output	kW	14,5
Thermal efficiency	%	88,0
Nominal consumption	kg/h	4,0
Flue outlet	Ø	20
Weight	kg	225
Weight with heat exchanger	kg	282
Dimensions	cm	80,4x58,4x177,3

MAIN FEATURES



GENERAL CHARACTERISTICS

- Steel firebox
- Rise n'fall door
- External air kit
- Levelling feet
- Adjustable feet

OPTIONAL

- Vacuum

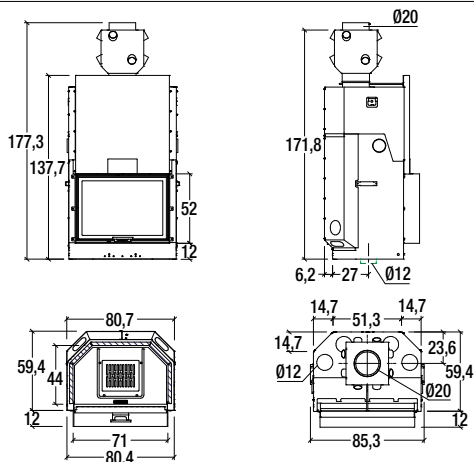

Model: ME 70

Con mantello cappa / With hood cover

Rivestimenti disponibili - Available surrounds P.98



Energy class		A+
Type		ME90-01
Room heating capacity	m ³	235 - 400
Nominal heat output	kW	14,0
Thermal efficiency	%	86,0
Nominal consumption	kg/h	4,0
Flue outlet	Ø	25
Weight	kg	295
Weight with heat exchanger	kg	330
Dimensions	cm	102x66x174,2

MAIN FEATURES



GENERAL CHARACTERISTICS

- Steel firebox
- Rise n'fall door
- External air kit
- Levelling feet
- Adjustable feet

OPTIONAL

- Vacuum

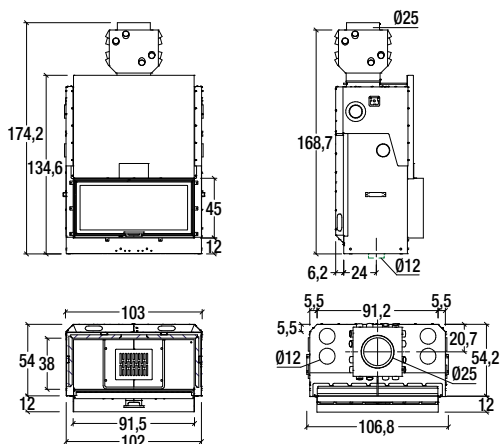

Model: ME 90

Con mantello cappa / With hood cover

Rivestimenti disponibili - Available surrounds P.98



Energy class		A+
Type		ME90B-01
Room heating capacity	m ³	250 - 430
Nominal heat output	kW	15,0
Thermal efficiency	%	82,5
Nominal consumption	kg/h	4,54
Flue outlet	Ø	25
Weight	kg	275
Weight with heat exchanger	kg	300
Dimensions	cm	102x71,5x174,2

MAIN FEATURES



GENERAL CHARACTERISTICS

- Steel firebox
- Rise n'fall door
- External air kit
- Levelling feet
- Adjustable feet

OPTIONAL

- Vacuum

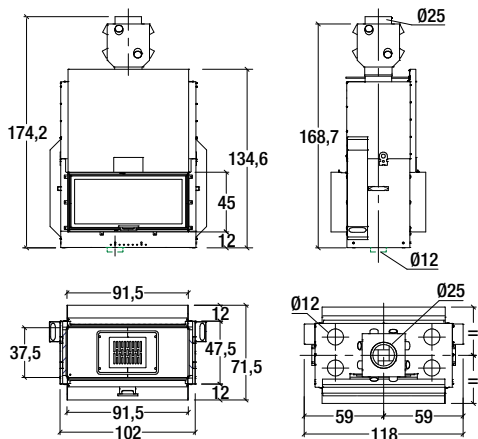

Model: ME 90 B

Con mantello cappa / With hood cover

Rivestimenti disponibili - Available surrounds P.98



Energy class		A+
Type		ME90DS-01
Room heating capacity	m ³	270 - 460
Nominal heat output	kW	16,0
Thermal efficiency	%	81,0
Nominal consumption	kg/h	4,8
Flue outlet	Ø	25
Weight	kg	330
Weight with heat exchanger	kg	365
Dimensions	cm	107,8x76x175,4

MAIN FEATURES



GENERAL CHARACTERISTICS

- Steel firebox
- Rise n'fall door
- External air kit
- Levelling feet
- Adjustable feet

OPTIONAL

- Vacuum

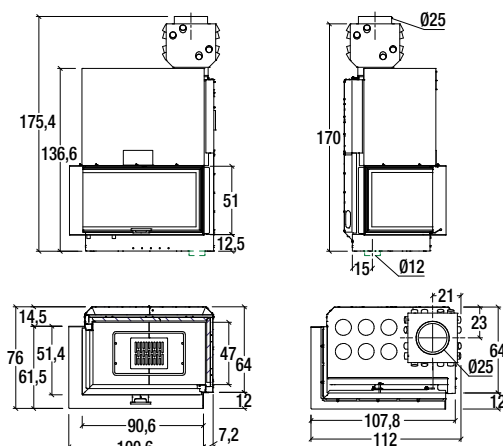

Model: ME 90 D, ME 90 S

Con mantello cappa / With hood cover

Rivestimenti disponibili - Available surrounds P.98



Rivestimenti





MA SL PLUS



FOCOLARI COMPATTI AD ALTA EFFICIENZA

Nei focolari MA SL PLUS a legna si fondono la dimensione generosa tipica del focolare tradizionale a legna, il disegno moderno e l'apertura con anta saliscendi che lo rendono particolarmente funzionale. Si può godere del comfort della convezione naturale o scegliere di sfruttare il kit Multifuoco® System o Multifuoco® System Plus, canalizzabile.

FR Monoblocs compacts à haut rendement

Particulièrement fonctionnels, les monoblocs MA SL PLUS à bois réunissent la dimension généreuse typique des foyers traditionnels, un design moderne et une ouverture verticale. Vous pouvez profiter du confort de la convection naturelle ou choisir d'utiliser le système Multifuoco® ou le kit Multifuoco® System Plus, qui peuvent être canalisés.

DE Kompakte Feuerstellen mit hohem Wirkungsgrad

Die Heizeinsätze MA SL PLUS für Holzfeuerung vereinen die großzügigen Maße herkömmlicher Holz-Feuerräume mit modernem Design und besonders funktionaler Öffnung mit Hebe-/Senksystem. Sie können den Komfort der natürlichen Konvektion genießen oder das Multifuoco® System- oder Multifuoco® System Plus-Kit verwenden, das geleitet werden kann.

EN Compact fireboxes with high efficiency

The MA SL PLUS wood-burning fireboxes combine the broad dimensions typical of traditional wood-burning fireplaces, modern design and the lifting door, which make the products highly functional. You can enjoy the comfort of natural convection or choose to use the Multifuoco® System or Multifuoco® System Plus kit, which can be ducted.

NL Compacte vuurhaarden met een hoog rendement

In de monoblokken MA SL PLUS op hout worden de royale afmetingen van de traditionele vuurhaard op hout, het moderne design en de opening met verticale schuifdeur gecombineerd. U kunt genieten van het comfort van natuurlijke convectie of ervoor kiezen om het Multifuoco® System of Multifuoco® System Plus kit te gebruiken, die kan worden afgevoerd.

ES Monobloques compactas de alta eficiencia

El monobloque MA SL PLUS de leña une el amplio tamaño típico del hogar tradicional de leña, un diseño moderno y la apertura con puerta corredera vertical, para ofrecer alta funcionalidad. Puede disfrutar de la comodidad de la convección natural o optar por utilizar el kit Multifuoco® System o Multifuoco® System Plus, que se pueden canalizar.



MA 260 SL PLUS



Energy class		A+
Type		MA260SL-01
Room heating capacity	m ³	225 - 390
Nominal heat output	kW	14,0
Thermal efficiency	%	87,2
Nominal consumption	kg/h	4,0
Flue outlet	Ø	20
Weight	kg	200
Dimensions	cm	80,4x59,4x177,2

MAIN FEATURES



GENERAL CHARACTERISTICS

- Steel firebox
- Rise n'fall door
- External air kit
- Levelling feet
- Adjustable feet
- Cooking pro kit

OPTIONAL

- Vacuum

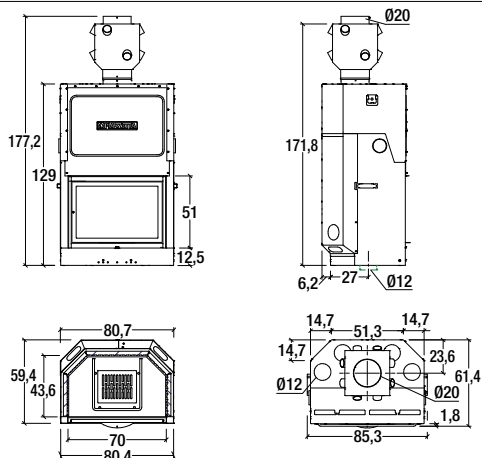

Model: MA 260 SL PLUS

Con mantello cappa / With hood cover

Rivestimenti disponibili - Available surrounds P.98

MA 261 SL PLUS



Energy class		A+
Type		MA261SL-02
Room heating capacity	m ³	235 - 400
Nominal heat output	kW	14,0
Thermal efficiency	%	85,2
Nominal consumption	kg/h	4,0
Flue outlet	Ø	25
Weight	kg	258
Dimensions	cm	90,4x71,4x183,3

MAIN FEATURES



GENERAL CHARACTERISTICS

- Steel firebox
- Rise n'fall door
- External air kit
- Levelling feet
- Adjustable feet
- Cooking pro kit

OPTIONAL

- Vacuum

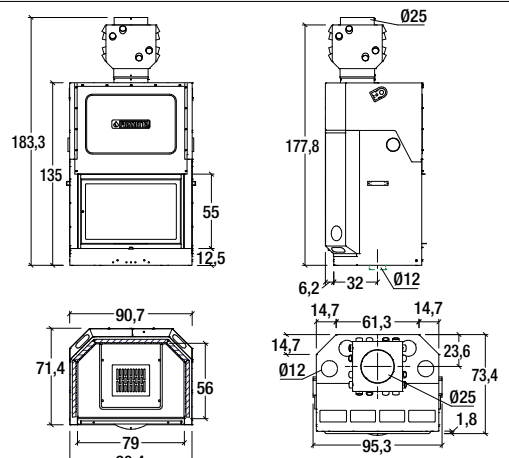

Model: MA 261 SL PLUS

Con mantello cappa / With hood cover

Rivestimenti disponibili - Available surrounds P.98

MA 262 SL PLUS



Energy class		A+
Type		MA262SL-01
Room heating capacity	m ³	275 - 475
Nominal heat output	kW	16,5
Thermal efficiency	%	81,1
Nominal consumption	kg/h	4,8
Flue outlet	Ø	25
Weight	kg	320
Dimensions	cm	102x54x186,2

MAIN FEATURES



GENERAL CHARACTERISTICS

- Steel firebox
- Rise n'fall door
- External air kit
- Levelling feet
- Adjustable feet

OPTIONAL

- Vacuum

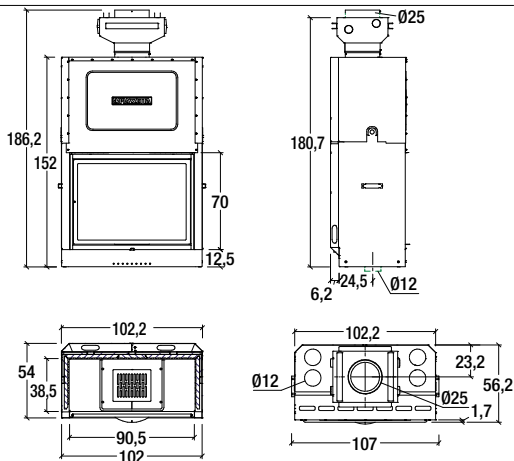

Model: MA 262 SL PLUS

Con mantello cappa / With hood cover

Rivestimenti disponibili - Available surrounds P.98

PIAZZETTA

MA 263 SL PLUS



Energy class		A+
Type		MA263SL-01
Room heating capacity	m ³	210 - 360
Nominal heat output	kW	12,5
Thermal efficiency	%	86,7
Nominal consumption	kg/h	3,6
Flue outlet	Ø	25
Weight	kg	260
Dimensions	cm	102x54x174

MAIN FEATURES



GENERAL CHARACTERISTICS

- Steel firebox
- Rise n'fall door
- External air kit
- Levelling feet
- Adjustable feet

OPTIONAL

- Vacuum

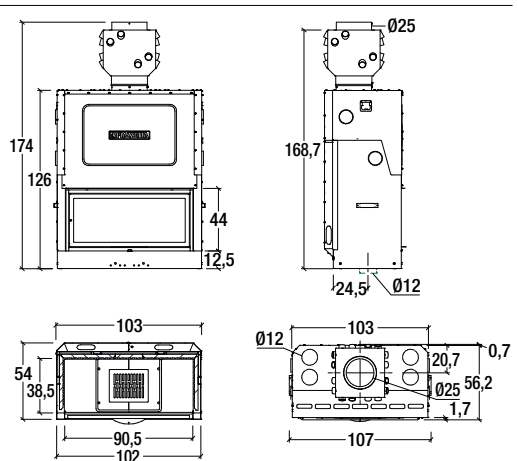

Model: MA 263 SL PLUS

Con mantello cappa / With hood cover

Rivestimenti disponibili - Available surrounds P.98

MA 263 B SL PLUS



Energy class		A+
Type		MA263BSL-01
Room heating capacity	m ³	225 - 390
Nominal heat output	kW	13,5
Thermal efficiency	%	80,8
Nominal consumption	kg/h	4,0
Flue outlet	Ø	20
Weight	kg	235
Dimensions	cm	102x48x174

MAIN FEATURES



GENERAL CHARACTERISTICS

- Steel firebox
- Rise n'fall door
- External air kit
- Levelling feet
- Adjustable feet

OPTIONAL

- Vacuum

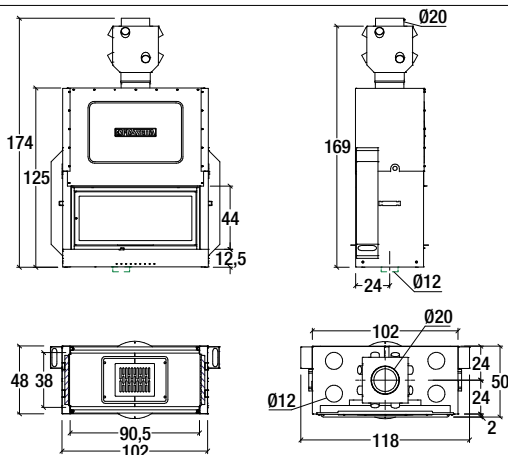

Model: MA 263 B SL PLUS

Con mantello cappa / With hood cover

Rivestimenti disponibili - Available surrounds P.98

MA 271 SL PLUS



Energy class		A
Type		MA271SL-01
Room heating capacity	m ³	270 - 460
Nominal heat output	kW	16,0
Thermal efficiency	%	77,5
Nominal consumption	kg/h	5,2
Flue outlet	Ø	25
Weight	kg	295
Dimensions	cm	97,2x65,8x182

MAIN FEATURES



GENERAL CHARACTERISTICS

- Steel firebox
- Rise n'fall door
- External air kit
- Levelling feet
- Adjustable feet

OPTIONAL

- Vacuum

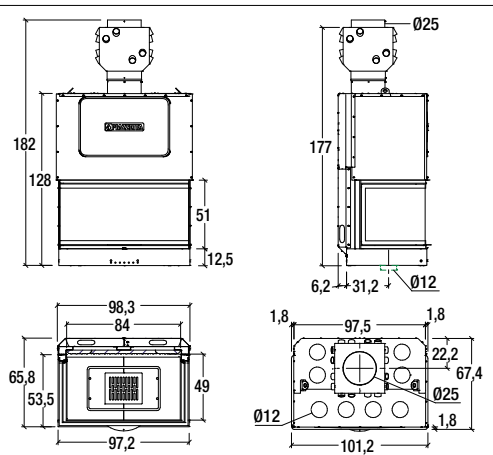

Model: MA 271 SL PLUS

Con mantello cappa / With hood cover

Rivestimenti disponibili - Available surrounds P.98

MA 272 SL PLUS



Energy class		A
Type		MA272SL-01
Room heating capacity	m ³	220 - 375
Nominal heat output	kW	13,0
Thermal efficiency	%	78,3
Nominal consumption	kg/h	3,9
Flue outlet	Ø	25
Weight	kg	315
Dimensions	cm	59x102x175

MAIN FEATURES



GENERAL CHARACTERISTICS

OPTIONAL

- Vacuum
- Levelling feet

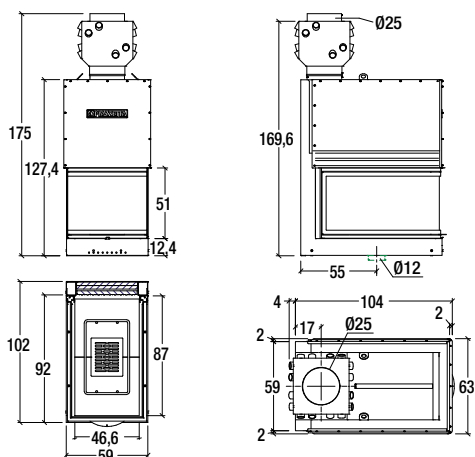

Model: MA 272 SL PLUS

Rivestimenti disponibili - Available surrounds P.98

PIAZZETTA

MA 283 D/S SL PLUS



Energy class		A
Type		MA283SL-02
Room heating capacity	m ³	270 - 460
Nominal heat output	kW	16,0
Thermal efficiency	%	80,4
Nominal consumption	kg/h	4,8
Flue outlet	Ø	25
Weight	kg	270
Dimensions	cm	95,8x64,2x175,4

MAIN FEATURES



GENERAL CHARACTERISTICS

- Steel firebox
- External air kit
- Rise n'fall door
- Levelling feet
- Adjustable feet

OPTIONAL

- Vacuum

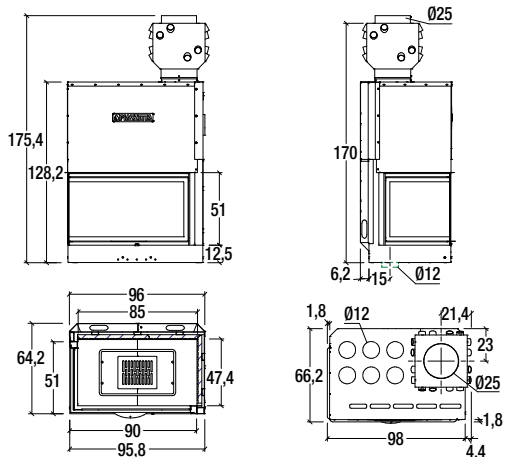

Model: MA 283 SL PLUS

Con mantello cappa / With hood cover

Rivestimenti disponibili - Available surrounds P.98



Energy class		A
Type		MA285SL-01
Room heating capacity	m ³	220 - 375
Nominal heat output	kW	13,0
Thermal efficiency	%	80,3
Nominal consumption	kg/h	4,0
Flue outlet	Ø	25
Weight	kg	215
Dimensions	cm	81,4x56,2x175,4

MAIN FEATURES



GENERAL CHARACTERISTICS

- Steel firebox
- External air kit
- Rise n'fall door
- Levelling feet
- Adjustable feet

OPTIONAL

- Vacuum

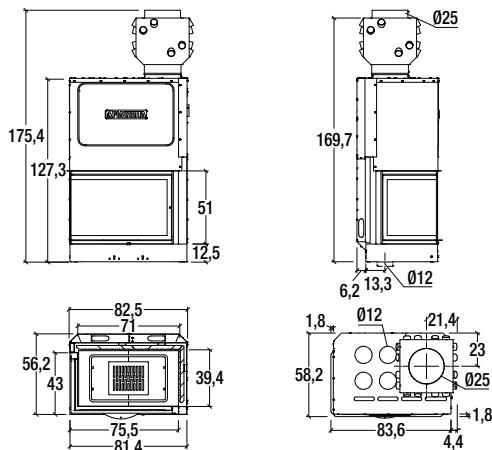

Model: MA 285 SL PLUS

Con mantello cappa / With hood cover

Rivestimenti disponibili - Available surrounds P.98

Rivestimenti



Phoenix



Colonia



Surface



MA SL



FOCOLARI COMPATTI CON ANTA SALISCENDI

Nei focolari MA SL a legna si fondono la dimensione generosa tipica del focolare tradizionale a legna, il disegno moderno e l'apertura con anta saliscendi che lo rendono particolarmente funzionale. Si può godere del crepitio della legna tenendo l'anta parzialmente aperta o scegliere di sfruttare il kit cottura per piacevoli serate con gli amici.

FR Monoblocs compacts avec porte à ouverture verticale

Particulièrement fonctionnels, les monoblocs MA SL à bois réunissent la dimension généreuse typique des foyers traditionnels, un design moderne et une ouverture verticale. En laissant la porte partiellement ouverte, on pourra profiter du crépitement du feu. Pour d'agréables soirées entre amis, on choisira d'utiliser le kit de cuisson.

DE Kompakte heizeinsätze mit öffnung durch hebe- und senksystem

Die Heizeinsätze MA SL für Holzfeuerung vereinen die großzügigen Maße herkömmlicher Holz-Feuerräume mit modernem Design und besonders funktionaler Öffnung mit Hebe-/Senksystem. Um das Knistern des Holzes zu genießen, kann die Tür leicht geöffnet gehalten oder das Cooking-Pro Set für gemütliche Abende mit Freunden genutzt werden.

EN Compact fireboxes with lifting door

The MA SL wood-burning fireboxes combine the broad dimensions typical of traditional wood-burning fireplaces, modern design and the lifting door, which make the products highly functional. Opening the door partly allows for enjoying the crackling sound of fire, or using the cooking kit ensures a pleasant evening with friends.

NL Compacte vuurhaarden met verticale schuifdeur

In de monoblokken MA SL op hout worden de royale afmetingen van de traditionele vuurhaard op hout, het moderne design en de opening met verticale schuifdeur gecombineerd. U kunt genieten van het knappen van het houtvuur door de deur gedeeltelijk open te laten of u kunt kiezen voor de kookkit voor gezellige avonden met uw vrienden.

ES Monobloques compactos con puerta corredera vertical

El monobloque MA SL de leña une el amplio tamaño típico del hogar tradicional de leña, un diseño moderno y la apertura con puerta corredera vertical, para ofrecer alta funcionalidad. Es posible disfrutar del crujido de la leña manteniendo la puerta parcialmente abierta o utilizar el kit de cocción para agradables veladas con amigos.



MA 260 SL



Energy class		A+
Type		MA260SL-02
Room heating capacity	m ³	225 - 390
Nominal heat output	kW	13,5
Thermal efficiency	%	83,5
Nominal consumption	kg/h	3,9
Flue outlet	Ø	20
Weight	kg	157
Dimensions	cm	85x53x137

MAIN FEATURES



GENERAL CHARACTERISTICS

OPTIONAL

- Levelling feet
- Adjustable feet
- Log retainer
- Vacuum

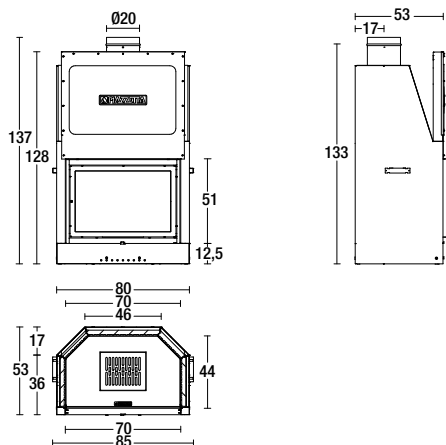

Model: MA 260 SL

Rivestimenti disponibili - Available surrounds P.98

MA 261 SL



Energy class		A+
Type		MA261SL-03
Room heating capacity	m ³	270 - 460
Nominal heat output	kW	16,0
Thermal efficiency	%	81,5
Nominal consumption	kg/h	4,8
Flue outlet	Ø	25
Weight	kg	206
Dimensions	cm	94x65x143,5

MAIN FEATURES



GENERAL CHARACTERISTICS

OPTIONAL

- Levelling feet
- Adjustable feet
- Log retainer
- Vacuum

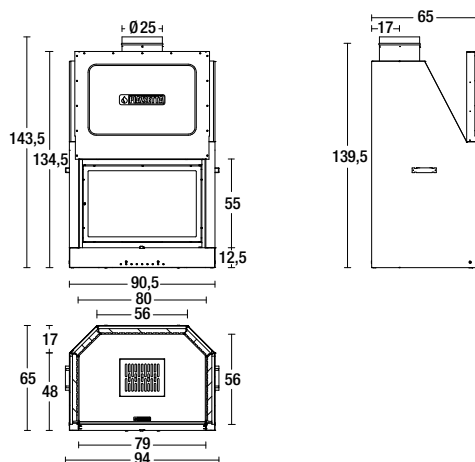

Model: MA 261 SL

Rivestimenti disponibili - Available surrounds P.98

MA 262 SL



Energy class		A
Type		MA262SL-02
Room heating capacity	m ³	295 - 500
Nominal heat output	kW	17,5
Thermal efficiency	%	80,5
Nominal consumption	kg/h	5,3
Flue outlet	Ø	25
Weight	kg	265
Dimensions	cm	107,5x48x160

MAIN FEATURES

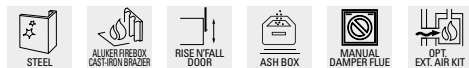

GENERAL CHARACTERISTICS

OPTIONAL

- Levelling feet
- Adjustable feet
- Vacuum

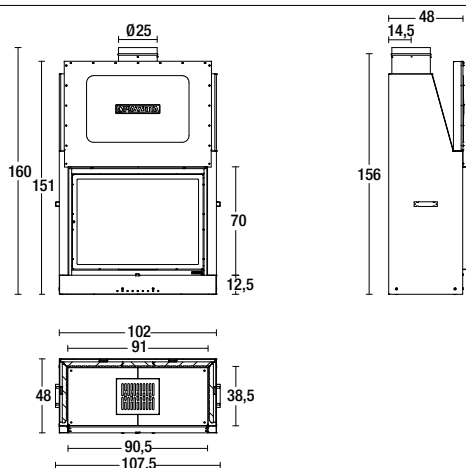

Model: MA 262 SL

Rivestimenti disponibili - Available surrounds P.98

PIAZZETTA

MA 263 SL



Energy class		A+
Type		MA263SL-02
Room heating capacity	m ³	220 - 375
Nominal heat output	kW	13,0
Thermal efficiency	%	83,2
Nominal consumption	kg/h	3,8
Flue outlet	Ø	25
Weight	kg	205
Dimensions	cm	102x48x134

MAIN FEATURES



GENERAL CHARACTERISTICS

OPTIONAL

- Levelling feet
- Adjustable feet
- Vacuum

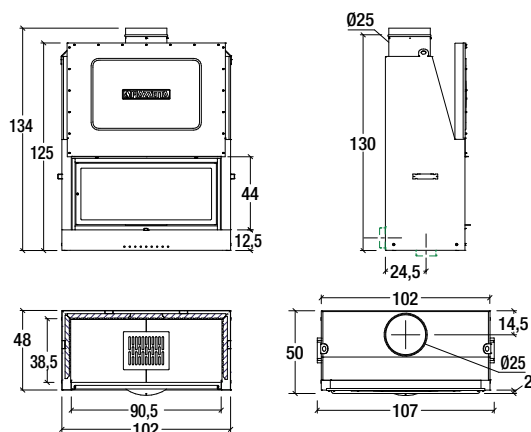

Model: MA 263 SL

Rivestimenti disponibili - Available surrounds P.98



Energy class		A
Type		MA283SL-01
Room heating capacity	m ³	225 - 390
Nominal heat output	kW	13,5
Thermal efficiency	%	75,0
Nominal consumption	kg/h	4,1
Flue outlet	Ø	25
Weight	kg	185
Dimensions	cm	96x58x135,5

MAIN FEATURES



GENERAL CHARACTERISTICS

OPTIONAL

- Levelling feet
- Adjustable feet
- Vacuum

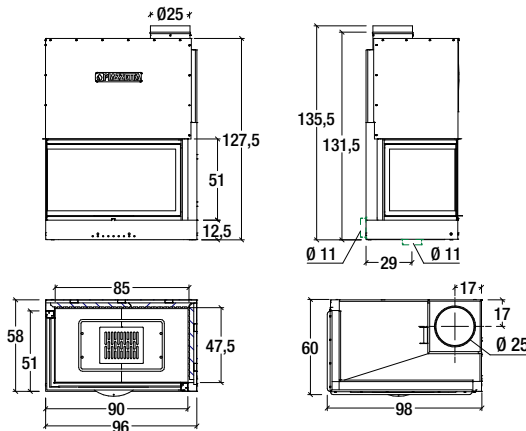

Model: MA 283 DX SL - MA 283 SX SL

Rivestimenti disponibili - Available surrounds P.98

Rivestimenti





Rivestimenti



Berna



Lithos



Essen



INSERTI A LEGNA

Gli inserti a legna IL sono appositamente sviluppati per essere installati in caminetti tradizionali già esistenti, migliorandone prestazioni e sicurezza e più pratico l'utilizzo. Sono ideali anche per prime installazioni. La geometria del flusso calibrato per l'aria primaria e il doppio sistema per l'aria terziaria ottimizzano i rendimenti.

FR Inserts à bois

Spécialement conçus pour être installés dans les cheminées existantes, les inserts à bois en améliorent les performances, la sécurité et rendent leur utilisation plus pratique. Ils sont aussi parfaits pour une première installation. Les rendements sont optimisés par la géométrie du flux d'air primaire et le double système d'air tertiaire.

DE Holz-kamineinsätze

Die Holz-Einsätze der Baureihe IL wurden speziell für den Einbau in bestehende herkömmliche Kamine entwickelt, um deren Leistung und Sicherheit sowie praktische Nutzbarkeit zu erhöhen. Sie sind auch für Erstinstallationen ideal. Geometrie des kalibrierten Primärluftstroms und doppeltes System für Tertiärluft optimieren die Wirkungsgrade.

EN Wood-burning inserts

IL wood-burning inserts can be installed in existing traditional fireplaces, where they improve the latter's performance and safety and make them more practical. They are also ideal for first-time installation. The geometry of the calibrated flow for primary air and the dual system for tertiary air optimise the performances.

NL Hout-inzetstukken

De hout-inzetstukken IL zijn speciaal ontwikkeld voor installatie in bestaande traditionele haarden, en verbeteren de prestaties, de veiligheid en het gebruiksgemak. Ook ideaal voor een eerste installatie. De geometrie van de gekalibreerde stroom voor primaire lucht en het dubbele systeem voor tertiaire lucht optimaliseren het rendement.

ES Hogares de leña

Los hogares de leña IL se han concebido para la instalación en chimeneas tradicionales ya existentes, para mejorar el desempeño y la seguridad y ofrecer un uso más práctico. Ideales también para primeras instalaciones. La forma del flujo calibrado para el aire primario y el doble sistema para el aire terciario optimizan el rendimiento.





Energy class		A
Type		SL320-02
Room heating capacity	m ³	150 - 260
Nominal heat output	kW	9,0
Thermal efficiency	%	80,5
Nominal consumption	kg/h	2,7
Flue outlet	Ø	15
Weight	kg	96
Dimensions	cm	50,5x43x57

MAIN FEATURES



GENERAL CHARACTERISTICS

OPTIONAL

- Vacuum

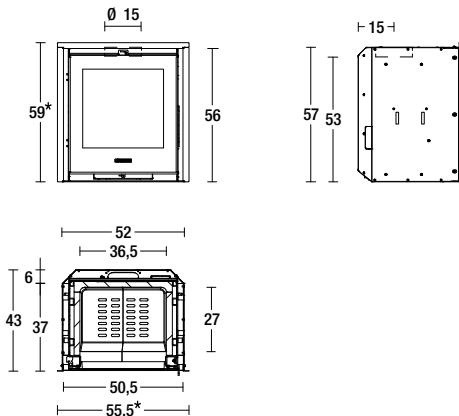

Model: IL 52/57

*Dimensioni con profili./Dimensions with trims.

Rivestimenti disponibili - Available surrounds P.98



Energy class		A
Type		IL 65/49
Room heating capacity	m ³	120 - 200
Nominal heat output	kW	7,0
Thermal efficiency	%	80,1
Nominal consumption	kg/h	1,9
Flue outlet	Ø	15
Weight	kg	105
Dimensions	cm	65x43x49

MAIN FEATURES



GENERAL CHARACTERISTICS

OPTIONAL

- Vacuum

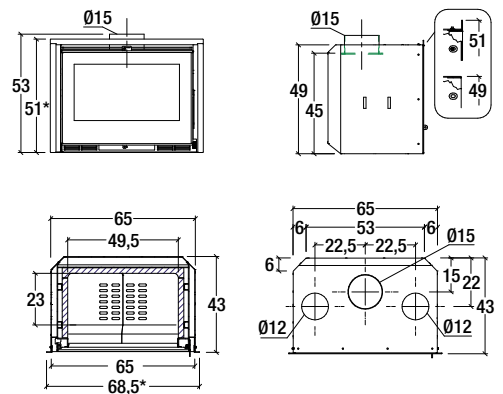

Model: IL 65/49

*Dimensioni con profili./Dimensions with trims.

Rivestimenti disponibili - Available surrounds P.98



Energy class		A
Type		IL 65/54
Room heating capacity	m ³	120 - 200
Nominal heat output	kW	7,0
Thermal efficiency	%	78,1
Nominal consumption	kg/h	2,0
Flue outlet	Ø	15
Weight	kg	110
Dimensions	cm	65x43x54

MAIN FEATURES



GENERAL CHARACTERISTICS

OPTIONAL

- Vacuum

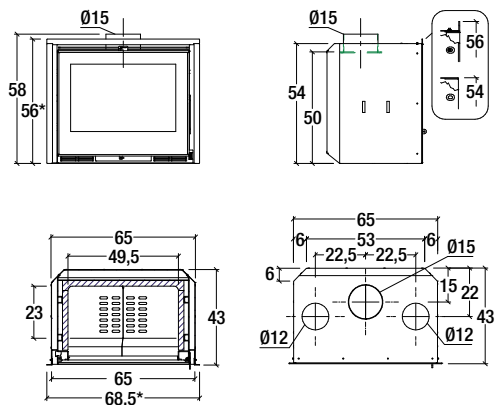

Model: IL 65/54

*Dimensioni con profili./Dimensions with trims.

Rivestimenti disponibili - Available surrounds P.98



Energy class		A
Type		IL 65/56 V
Room heating capacity	m ³	120 - 200
Nominal heat output	kW	7,0
Thermal efficiency	%	80,0
Nominal consumption	kg/h	1,9
Flue outlet	Ø	15
Weight	kg	120
Dimensions	cm	65x43x56

MAIN FEATURES



GENERAL CHARACTERISTICS

OPTIONAL

- Vacuum

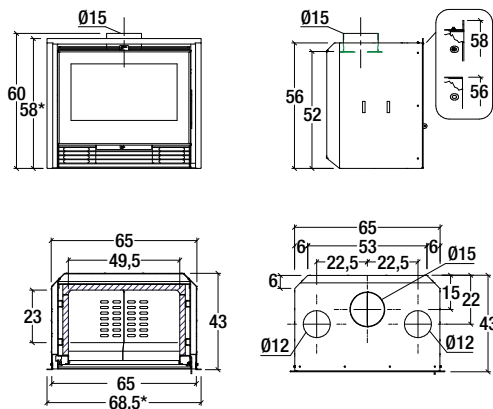

Model: IL 65/56 V

*Dimensioni con profili./Dimensions with trims.

Rivestimenti disponibili - Available surrounds P.98



Energy class		A
Type		IL 75/58
Room heating capacity	m ³	150 - 260
Nominal heat output	kW	9,0
Thermal efficiency	%	80,0
Nominal consumption	kg/h	2,4
Flue outlet	Ø	18
Weight	kg	125
Dimensions	cm	73,5x43x58

MAIN FEATURES



GENERAL CHARACTERISTICS

OPTIONAL

- Vacuum

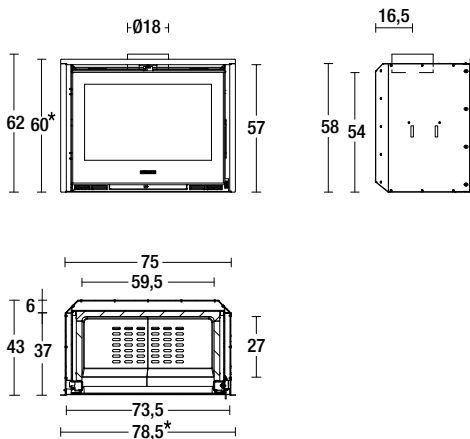

Model: IL 75/58

*Dimensioni con profil./Dimensions with trims.

Rivestimenti disponibili - Available surrounds P.98



Energy class		A
Type		IL 75/64
Room heating capacity	m ³	150 - 260
Nominal heat output	kW	9,0
Thermal efficiency	%	79,7
Nominal consumption	kg/h	2,4
Flue outlet	Ø	18
Weight	kg	132
Dimensions	cm	75x43x64

MAIN FEATURES



GENERAL CHARACTERISTICS

OPTIONAL

- Vacuum

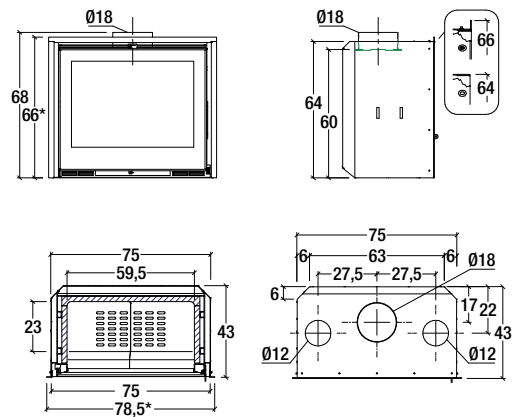

Model: IL 75/64

*Dimensioni con profil./Dimensions with trims.

Rivestimenti disponibili - Available surrounds P.98



Energy class		A
Type		IL 75/66 V
Room heating capacity	m ³	150 - 260
Nominal heat output	kW	9,0
Thermal efficiency	%	80,0
Nominal consumption	kg/h	2,4
Flue outlet	Ø	18
Weight	kg	147
Dimensions	cm	75x43x66

MAIN FEATURES



GENERAL CHARACTERISTICS

OPTIONAL

- Vacuum

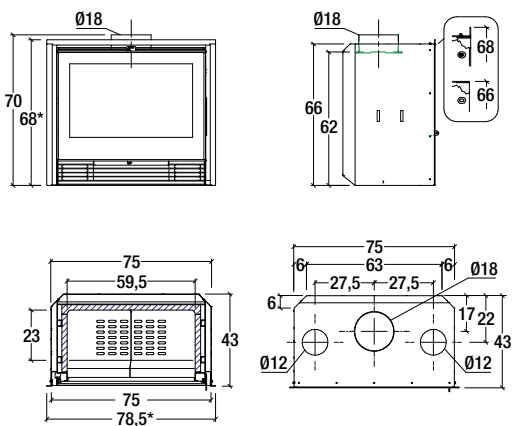

Model: IL 75/66 V

*Dimensioni con profili./Dimensions with trims.

Rivestimenti disponibili - Available surrounds P.98



Energy class		A+
Type		SL31-01
Room heating capacity	m ³	185 - 315
Nominal heat output	kW	5,5 - 11,0
Thermal efficiency	%	83,1 - 86,0
Nominal consumption	kg/h	1,5 - 2,9
Flue outlet	Ø	15
Weight	kg	227
Dimensions	cm	45,3x44,4x111,9

MAIN FEATURES



GENERAL CHARACTERISTICS

- Natural convection
 - Ash box
 - Vacuum
 - Tertiary air
 - Glass air wash
 - Aluker firebox
 - Cast-iron brazier
 - Steel firebox
- OPTIONAL
- External air kit

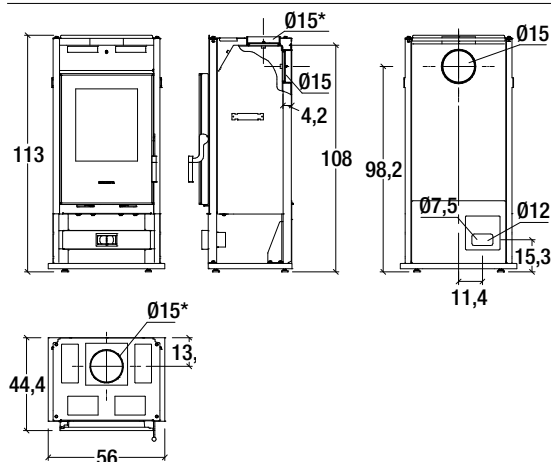

Model: E928 WF

Rivestimenti disponibili - Available surrounds P.98



Energy class		A+
Type		SL32-01
Room heating capacity	m ³	185 - 320
Nominal heat output	kW	5,5 - 11,1
Thermal efficiency	%	84,8 - 86,6
Nominal consumption	kg/h	1,4 - 2,9
Flue outlet	Ø	15
Weight	kg	227
Dimensions	cm	45,3x44,4x112

MAIN FEATURES



GENERAL CHARACTERISTICS

- Natural convection
 - Burn Control System
 - Tertiary air
 - Aluker firebox
 - Cast-iron brazier
 - Steel firebox
 - Ash box
 - Glass air wash
- OPTIONAL
- Vacuum

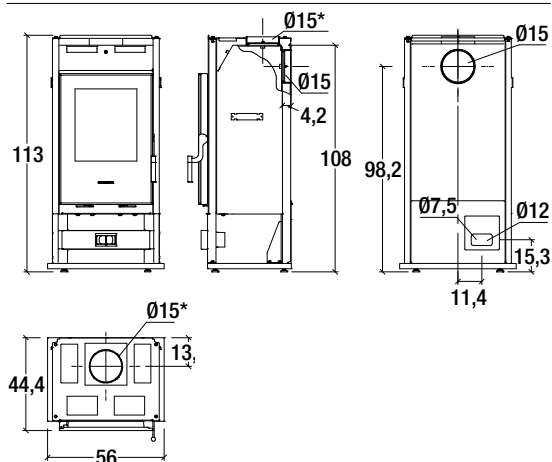

Model: E928 WF BCS

Rivestimenti disponibili - Available surrounds P.98

Rivestimenti



